

**CITY OF ROCKLIN**  
**STANDARD DRAWINGS**

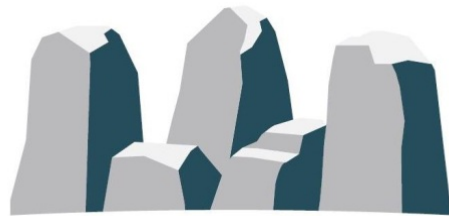

**ROCKLIN**  
CALIFORNIA

November 2016

# Table of Contents

	Page #
<b>Section 1</b>	<b>General Notes and Review Boxes</b>
	01-01 Signature Blocks ..... 1
	01-02 General Notes (Sheet 1 of 8) ..... 2
	01-03 General Notes (Sheet 2 of 8) ..... 3
	01-04 General Notes (Sheet 3 of 8) ..... 4
	01-05 General Notes (Sheet 4 of 8) ..... 5
	01-06 General Notes (Sheet 5 of 8) ..... 6
	01-07 Landscaping General Notes (Sheet 6 of 8) ..... 7
	01-08 General Notes (Sheet 7 of 8) ..... 8
	01-09 General Notes (Sheet 8 of 8) ..... 9
	01-10 Building Permit Block ..... 10
	01-11 Lot Pad Certification Signature Block ..... 11
	01-12 Record Drawing Signature Block ..... 12
<b>Section 2</b>	<b>Grading</b>
	02-01 Exterior Perimeter Property Line Grading..... 13
	02-02 Interior Property Line Grading ..... 14
	02-03 Redwood Retaining Wall Detail..... 15
<b>Section 3</b>	<b>Street</b>
	03-01 Typical Sections Residential Streets ..... 16
	03-02 Typical Sections Residential Collector Streets..... 17
	03-03 Typical Sections-Industrial & Commercial / Collector Approach to Arterials ..... 18
	03-04 Typical Sections Minor Arterial Streets ..... 19
	03-05 Typical Sections Primary Arterial Streets ..... 20
	03-06A Typical Sections Semi Rural ..... 21
	03-06B Improved Street with Vegetated Soil ..... 22
	03-07 Cul-De-Sac..... 23
	03-08 90° Intersection Elbow ..... 24
	03-09 Standard Casting Adjusting Detail and Cold Planing Detail of Existing Streets..... 25
	03-10 Bus Turnout ..... 26
	03-11 Widening Details at Major Street Intersections..... 27
	03-12 Sight Distance Requirements for 80' & 90' Streets..... 28
	03-13 Sight Distance Requirements for 120' Streets ..... 29
	03-14 Visibility Requirements..... 30
	03-15 Curbs and Gutters..... 31
	03-15A Valley Gutter..... 32
	03-16 Sidewalk Ramps..... 33
	03-17 Planter and Barrier Curb Details ..... 34

03-18 Residential Standard Driveway .....	35
03-19 Commercial and Industrial Standard Driveway.....	36
03-20 Driveway Approach Detail for Areas With Curb & Gutter; No Sidewalks .....	37
03-21 Alley Details and Driveway Transitions .....	38
03-22 Commercial Frontage and Driveway Regulations .....	39
03-23 Special Commercial Frontage Entrance Type A-7 .....	40
03-24 Sidewalk Barricade .....	41
03-25 Street Closure Gated Timber Barricade .....	42
03-26 Signs and Barricades at End Of Pavement Widening.....	43
03-27 Pedestrian Lane with Bike Barrier .....	44
03-28 Residential Street Signs .....	45
03-29 Street Name Sign Installation on Street Light Pole .....	46
03-30 Street Light & Street Sign Placement Details.....	47
03-31 Typical Intersection Markings .....	48
03-32 Typical Off-Street Parking.....	49
03-33 Handicap Parking Space Layout Detail.....	50
03-34 Boxed Survey Monument for Centerline Intersection.....	51
03-35 Detectable Warning Truncated Dome Panel Retrofit or Replacement.....	52
03-36 Collapsing Bollard Detail.....	53
03-37 Typical Traffic Control Lane Closure/Transition.....	54
03-38 Permitted Driveways or Streets On Minor Arterials .....	55
03-39 Standard Concrete Joint Details.....	56
03-40 Mow Band .....	57
03-41 Private Gated Entrance .....	58
03-42 RW Fence-Farm with Steel Posts.....	59
03-43 Wood Post and Cable Fence.....	60
03-44 Tubular Steel Post and Cable Fence .....	61
03-45 AC Pedestrian Trail .....	62
03-46 Overall Sign Configuration Front View.....	63
03-47 Top Sign Bracket Configuration.....	64
03-48 Bottom Sign Bracket Configuration.....	65

**Section 4**

**Storm Water**

04-01 Drop Inlet Type "A" .....	66
04-02 Drop Inlet Type "B" .....	67
04-03 Drop Inlet Type "F" .....	68
04-04 Drop Inlet Frame and Grate For Type "A" & "B" Drop Inlets.....	69
04-05 Drop Inlet Grate for Type "F" Drop Inlets .....	70
04-06 Flow Capacity Type "A" & "B" Grates.....	71
04-07 Flow Capacity Type "F" Grates .....	72
04-08 Standard Precast Drainage Manhole .....	73
04-09 Type "A" & "B" Saddle Manhole .....	74

	04-10 Standard Drainage Manhole Frame and Cover .....	75
	04-11 Grate Type Manhole Cover .....	76
	04-12 Culvert Outfall and Stream Bank Slope Protection .....	77
	04-13 Erosion Control Pipe Discharge .....	78
	04-14 Erosion Control Ditch Discharge.....	79
	04-15 Pipe Inlet Structure.....	80
	04-16 Pipe Inlet Structure and Trash Rack – 30” Pipe and Smaller.....	81
	04-17 Pipe Outfall Access Control Rack.....	82
	04-18 Underdrains & Overside Drains.....	83
	04-19 Under Sidewalk Drain.....	84
	04-20 Flared End Section.....	85
	04-21 Concrete Pipe Connections .....	86
	04-22 Corrugated Pipe Fittings.....	87
	04-23 Typical Ramp and Transition Detail.....	88
	04-24 Typical Storm Drain Inlet Stamp.....	89
	04-25 P.V.C. Cleanout Detail.....	90
<b>Section 5</b>	<b>Trench Construction</b>	
	05-01 Concrete Pipe, Reinforce Concrete Pipe, HDPE and Cast-In-Place Conc. Pipe Cover Req. ....	91
	05-02 Corrugated Steel and Aluminum Pipe Cover Requirements.....	92
	05-03 Trench Excavation & Backfill .....	93
	05-04 Typical Joint Trench Configuration.....	94
<b>Section 6</b>	<b>Fire</b>	
	06-01 Fire Standards.....	95
<b>Section 7</b>	<b>Signals &amp; Lights</b>	
	07-01 Street Light Placement at Intersections .....	96
	07-02 Street Light Locations on Residential Streets.....	97
	07-03 Base Location for Street Lights.....	98
	07-04 Concrete Base Detail For Type “A” And “B” Street Lights.....	99
	07-05 No. 3 1/2 and No. 5 Pull Box Installation .....	100
	07-06 Street Light and Signal Pull Box Locations.....	101
	07-07 Typical Street Light Service Pad.....	102
	07-08 Unmetered Service Pedestal .....	103
	07-08A Metered Service Pedestal .....	104
	07-08B Metered Service Pedestal.....	105
	07-08C Dual Metered Service Pedestal .....	106
	07-09 Street Light Poles and Symbols .....	107
	07-10 Type “A” Street Lights for Major Streets and Collectors.....	108
	07-11 Type “B” Street Lights for Minor Streets.....	109
	07-12 Street Light Base Leveling Detail .....	110
	07-13 Typical Placement of Identification Decals on Luminaire .....	111
	07-14 Street Light Identification Decals .....	112
	07-15 Reflective Numerals and Letters for Street Light Marking.....	113

	07-16 Aluminum Number Plates .....	114
	07-17 Street Lighting Design Criteria.....	115
	07-18 Lateral Light Distribution.....	116
	07-19 Typical Voltage Drop Calculation for 3-Wire System .....	117
	07-20 Street Light Standard Wiring Diagram .....	118
<b>Section 8</b>	<b>Traffic Signal Infrastructure</b>	
	08-01 Typical Service and Wiring Schedule.....	119
	08-02 Typical Pole and Equipment Schedule .....	120
	08-03 Typical Conductor Schedule .....	121
	08-04 Typical Controller/Service Cabinet Detail .....	122
	08-05 Typical Loop Detector Layout.....	123
<b>Section 9</b>	<b>Landscaping</b>	
	09-01 Slope Planting.....	124
	09-02 Tree Planting – Single Stake .....	125
	09-03 Tree Planting – Double Stake .....	126
	09-04 Tree Guying .....	127
	09-05 Root Barrier Planter Box.....	128
	09-06 Shrub Planting Detail.....	129
	09-07 Concrete Landscaping Gutter.....	130
	09-08 Redwood Headerboard Detail.....	131
	09-09 Pop-up Lawn Sprinkler .....	132
	09-10 Bubbler Below Grade .....	133
	09-11 Pull Box.....	134
	09-12 24 Volt Splice Box.....	135
	09-13 Exterior Mount Automatic Controller .....	136
	09-14 Remote Control Valve .....	137
	09-15 Quick Coupler Valve .....	138
	09-16 Gate Valve .....	139
	09-17 Strainer / Pressure Reducing Valve Assembly.....	140
	09-18 Pipe Depth in Trenched.....	141
	09-19 Chain Link Fence .....	142

CITY OF ROCKLIN  
ENGINEERING DEPARTMENT

APPROVED BY: \_\_\_\_\_

\_\_\_\_\_  
CITY ENGINEER DATE

CITY OF ROCKLIN  
FIRE DEPARTMENT

APPROVED BY: \_\_\_\_\_

\_\_\_\_\_  
FIRE CHIEF DATE

DEPARTMENT OF PUBLIC SERVICES

APPROVED BY: \_\_\_\_\_

\_\_\_\_\_  
DIRECTOR DATE

SOILS REPORT

COMPANY NAME: \_\_\_\_\_

\_\_\_\_\_  
JOB NUMBER DATE

PLACER COUNTY WATER AGENCY

APPROVED BY: \_\_\_\_\_

\_\_\_\_\_  
ENGINEER DATE

SPMUD

APPROVED BY: \_\_\_\_\_

\_\_\_\_\_  
ENGINEER DATE

BUILDING DEPARTMENT PERMITS

DEFERRED SUBMITTAL REQUIRED TO BUILDING  
DEPARTMENT FOR:

\_\_\_\_\_  
\_\_\_\_\_



DRAWING APPROVED - CITY ENGINEER



DRAWING APPROVED - DIRECTOR OF PUBLIC SERVICES

CITY OF ROCKLIN  
ENGINEERING DIVISION



SIGNATURE BLOCKS

SCALE: NONE  
DATE: DECEMBER 2015  
DRAWN BY: J. PINKHAM



DWG #  
1-1

## PROJECT NOTES

1. THE CONTRACTOR SHALL NOT BEGIN ANY WORK SHOWN ON THESE PLANS UNTIL THE CITY ENGINEER'S SIGNATURE OF APPROVAL IS AFFIXED HEREON AND ALL APPLICABLE PERMITS HAVE BEEN OBTAINED.
2. CONTRACTOR SHALL ASSUME SOLE AND COMPLETE RESPONSIBILITY FOR CONSTRUCTION OF THIS PROJECT, INCLUDING SAFETY OF ALL PERSONS AND PROPERTY. THIS REQUIREMENT SHALL APPLY CONTINUOUSLY AND NOT BE LIMITED TO NORMAL WORKING HOURS. THE CONTRACTOR SHALL DEFEND, INDEMNIFY AND HOLD THE CITY, OWNER AND THE ENGINEER HARMLESS FROM ANY AND ALL LIABILITY ARISING FROM THE SOLE NEGLIGENCE OF THE CITY, OWNER OR ENGINEER.
3. THE CONTRACTOR IS HEREBY NOTIFIED THAT PRIOR TO COMMENCING CONSTRUCTION, HE SHALL CONTACT ALL UTILITY COMPANIES FOR VERIFICATION AT THE CONSTRUCTION SITE OF THE LOCATIONS OF ALL UNDERGROUND FACILITIES WHERE SUCH FACILITIES MAY CONFLICT WITH PLACEMENT OF IMPROVEMENTS SHOWN ON THIS PLAN. CALL "UNDERGROUND SERVICE ALERT" AT 811 (PHONE 800-227-2600) OR THROUGH THE WEBSITE AT [HTTP://USANORTH811.ORG](http://USANORTH811.ORG) 48 HOURS IN ADVANCE PRIOR TO ANY EXCAVATION.
4. THE LOCATIONS OF ALL UNDERGROUND FACILITIES SHOWN ON THIS PLAN ARE APPROXIMATE. A REASONABLE EFFORT HAS BEEN MADE TO LOCATE AND DELINEATE ALL UNDERGROUND FACILITIES; HOWEVER, THE ENGINEER ASSUMES NO LIABILITY FOR THE ACCURACY OR COMPLETENESS OF THE EXISTING FACILITIES SHOWN HEREON OR FOR THE EXISTENCE OF OTHER UNDERGROUND UTILITIES OR OBJECTS WHICH THE CONTRACTOR MAY DISCOVER, BUT ARE NOT SHOWN ON THESE PLANS. THE CONTRACTOR SHALL VERIFY THE LOCATION OF ALL EXISTING FACILITIES AND IMMEDIATELY NOTIFY THE ENGINEER IF ANY SUCH FACILITIES INTERFERE WITH THE CONSTRUCTION OF THE IMPROVEMENTS. THE CONTRACTOR SHALL STOP WORK UNTIL MITIGATIONS CAN BE MADE. ANY COSTS INCURRED RESULTING FROM CONTRACTOR'S FAILURE TO STOP AS DIRECTED SHALL BE THE RESPONSIBILITY OF THE CONTRACTOR.
5. ALL MATERIALS, METHODS, AND WORKMANSHIP SHALL CONFORM TO THE SPECIFICATION OF THE AGENCIES INVOLVED AND ALL WORK IS SUBJECT THE APPROVAL OF THEIR DIRECTOR OR AUTHORIZED REPRESENTATIVE.
6. THE CONTRACTOR SHALL NOTIFY THE CITY OF ROCKLIN'S PUBLIC SERVICES INSPECTORS MON.-FRI. 8:00 A.M. TO 4:00 P.M. AT (916) 625-5500 FOR A PRECONSTRUCTION MEETING 48 HOURS IN ADVANCE OF STARTING ANY CONSTRUCTION ACTIVITIES. PLACER COUNTY WATER AGENCY AND SOUTH PLACER MUNICIPAL UTILITY DISTRICT REQUIRE AT LEAST 48-HOURS PRIOR TO ANY CONSTRUCTION REQUESTS FOR INSPECTION OF PUBLIC FACILITIES. THEREFORE, NOTICE SHALL BE GIVEN 48-HOURS IN ADVANCE AND BE PERFORMED BY THE AGENCY'S DESIGNATED AGENT.
7. THE CONTRACTOR SHALL OBTAIN ALL NECESSARY ENCROACHMENT PERMITS AND SHALL POSSESS APPROVED PLANS PRIOR TO BEGINNING OF CONSTRUCTION. A SET OF SIGNED AND APPROVED PLANS ARE TO BE ON THE JOB SITE AT ALL TIMES.

 DRAWING APPROVED – CITY ENGINEER	CITY OF ROCKLIN ENGINEERING DIVISION	
	GENERAL NOTES (SHEET 1 OF 8)	
 DRAWING APPROVED – DIRECTOR OF PUBLIC SERVICES	SCALE: NONE DATE: MAY 2016 DRAWN BY: J. PINKHAM	DWG # 1-2



8. THE CONTRACTOR SHALL MAINTAIN THE EXISTING PUBLIC AND PRIVATE IMPROVEMENT WITHIN THE WORK AREA AND SHEL ADEQUATELY BARRICADE THE PROJECT SITE TO KEEP THE GENERAL PUBLIC FROM THE SITE. ANY IMPROVEMENTS DAMAGED DURING CONSTRUCTION SHALL BE REPLACED BY CONTRACTOR.
9. THE CONTRACTOR MUST EXPOSE THE END OF EXISTING GRAVITY LINES FOR THE SURVEYOR TO VERIFY LOCATION AND DEPTH OF FACILITIES PRIOR TO CONNECTION OF PROPOSED UTILITY. THE CONTRACTOR SHALL INCUR ALL COSTS FOR SUCH EXCAVATION.
10. THE CONTRACTOR SHALL AT ALL TIMES COORDINATE HIS WORK WITH THAT OF OTHERS ON THE SITE. THE CONTRACTOR SHALL HAVE A RESPONSIBLE PARTY, WHO SHALL HAVE THE AUTHORITY TO REPRESENT AND ACT FOR THE CONTRACTOR ON THE JOB SITE DURING ALL WORKING HOURS.
11. CONTRACTOR SHALL BE IN RECEIPT OF THE CITY APPROVED PLANS PRIOR TO CONSTRUCTION.
12. CONTRACTOR SHALL NOTIFY UTILITY COMPANIES INVOLVED IN THE DEVELOPMENT PRIOR TO BEGINNING OF WORK.
13. CONTRACTOR SHALL BE RESPONSIBLE FOR THE PROTECTION OF ALL EXISTING MONUMENTS AND/OR OTHER SURVEY MONUMENTS AND SHALL NOTIFY CITY OF ROCKLIN DEPARTMENT OF PUBLIC SERVICES OF ANY DAMAGED OR REMOVED CITY, STATE, OR BUREAU MONUMENTS. CONTRACTOR SHALL BE RESPONSIBLE TO RESTORE ANY DAMAGED OR REMOVED MONUMENTS.
14. CONTRACTOR SHALL NOTIFY DEPARTMENT OF PUBLIC SERVICES UPON APPLICATION FOR PERMIT AND PAYMENT OF REQUIRED FEE.
15. THE CONTRACTOR SHALL VERIFY ALL STREETS NAMES AND THEIR CORRECT SPELLING WITH THE FIRE DEPARTMENT AND BUILDING DIVISION BEFORE ORDERING STREET SIGNS.
16. CONTRACTOR SHALL BE RESPONSIBLE FOR CONDUCTING HIS OPERATION ENTIRELY OUTSIDE OF ANY FLOODPLAIN BOUNDARIES. FLOODPLAIN BOUNDARIES SHALL BE CLEARLY DELINEATED IN THE FIELD WITH ORANGE ESA FENCING AND SIX FOOT (6') STAKES TEN FEET (10') OC PRIOR TO CONSTRUCTION.
17. CONTRACTOR SHALL BE RESPONSIBLE FOR CONDUCTING HIS OPERATION ENTIRELY OUTSIDE OF ANY "NO GRADING AREA." THESE AREAS SHALL BE CLEARLY DELINEATED IN THE FIELD PRIOR TO CONSTRUCTION.
18. WHERE WORK IS BEING DONE IN AN OFFSITE EASEMENT THE CONTRACTOR SHALL NOTIFY THE PROPERTY OWNER 48 HOURS PRIOR TO COMMENCING WORK.

 DRAWING APPROVED – CITY ENGINEER	CITY OF ROCKLIN ENGINEERING DIVISION	
	GENERAL NOTES (SHEET 2 OF 8)	
 DRAWING APPROVED – DIRECTOR OF PUBLIC SERVICES	SCALE: NONE DATE: JUNE 2015 DRAWN BY: J. PINKHAM	DWG # 1-3



**STREETS**

1. PLACEMENT OF PROPOSED PUBLIC IMPROVEMENTS AND PROPOSED ONSITE IMPROVEMENTS SHALL NOT BE LIMITED TO THESE PLANS, BUT BE BUILT IN ACCORDANCE WITH THE CITY OF ROCKLIN IMPROVEMENT STANDARDS AND TO THE SATISFACTION OF THE CITY ENGINEER.
2. SIDEWALK RAMPS SHALL BE CONSTRUCTED AT THE CENTER OF ALL CURB RETURNS.
3. ALL UTILITY TRENCHING TO BE DONE AS PER TRENCH DETAILS.
4. ALL DROP INLETS SHALL BE TYPE "B" AS SHOWN IN THE CITY OF ROCKLIN IMPROVEMENT STANDARDS, DRAWING 4-2, EXCEPT AS NOTED.
5. CONSTRUCT SIDEWALK RAMPS PER LATEST CALTRANS STANDARDS.
6. CONSTRUCT MONUMENT BOX PER CITY OF ROCKLIN IMPROVEMENTS, STANDARD DRAWINGS 3-34.
7. STOP SIGNS, THERMOPLASTIC STOP BARS, AND THE THERMOPLASTIC WORD "STOP" SHALL CONFORM TO CALTRANS STANDARDS (R1, 30").
8. THE CONTRACTOR SHALL COORDINATE WITH ALL OTHER WORK TO ASSURE THAT ALL UNDERGROUND CONDUITS AND UTILITIES ARE INSTALLED PRIOR TO PAVING. ALL PIPES IN PAVED AREAS SHALL BE PLACED PRIOR TO PLACING AGGREGATE BASE. NO CURB, GUTTER, SIDEWALK FOR AGGREGATE BASE SHALL BE PLACED UNTIL ALL UNDERGROUND UTILITIES ARE INSTALLED.
9. EXISTING A.C. SURFACE SHALL BE CUT TO A NEAT STRAIGHT LINE, PARALLEL WITH THE STREET CENTERLINE AND THE EXPOSED EDGE AND VERTICAL EDGE OF GUTTER LIP SHALL BE TACKED WITH EMULSION PRIOR TO PAVING. THE CONTRACTOR SHALL PREVENT SAW CUT MATERIAL FROM ENTERING DRAINAGE STRUCTURES, WATERWAYS, DRAINAGE SWALES, ETC.  
  
MATERIAL SHALL BE GRADED, RECOMPACTED, AND RESEALED PRIOR TO PAVING. ANY CONCRETE, A.C., TREES, FENCES, AND/OR OTHER OBSTRUCTIONS REQUIRED TO CONSTRUCT THE IMPROVEMENT SHALL BE REMOVED PRIOR TO PAVING.
10. TRAFFIC CONTROL PROCEDURES SHALL CONFORM TO THE MOST RECENT EDITION OF THE CALIFORNIA MANUAL ON UNIFORM TRAFFIC CONTROL DEVICES (CA MUTCD). THE CONTRACTOR SHALL OBTAIN APPROVAL FROM THE CITY OF ROCKLIN FOR THE METHOD OF TRAFFIC CONTROL PRIOR TO STARTING CONSTRUCTION.
11. THE CONTRACTOR WILL BE RESPONSIBLE FOR ANY DAMAGE TO THE STREETS OR SIDEWALKS DURING THE CONSTRUCTION PHASE. IF THE CITY FINDS A SIGNIFICANT AMOUNT OF STREET DAMAGE, AN OVERLAY OF THE ENTIRE PROJECT OR STREET IN QUESTION WILL BE REQUIRED BEFORE A NOTICE OF COMPLETION IS PROCESSED. THE CONTRACTOR, DEVELOPER AND/OR BUILDER ARE TOTALLY RESPONSIBLE FOR THE QUALITY OF WORKMANSHIP ON THE PROJECT.

 DRAWING APPROVED – CITY ENGINEER	CITY OF ROCKLIN ENGINEERING DIVISION	
	GENERAL NOTES (SHEET 3 OF 8)	
 DRAWING APPROVED – DIRECTOR OF PUBLIC SERVICES	SCALE: NONE DATE: JUNE 2015 DRAWN BY: J. PINKHAM	DWG # 1-4

12. UTILITIES:



- SEWER: SO. PLACER MUNICIPAL UTILITY DISTRICT (916) 786-8522
- WATER: PLACER COUNTY WATER AGENCY (530) 823-4886
- STORM DRAIN, TELECOMMUNICATION CONDUIT  
STREET LIGHTS & TRAFFIC SIGNALS:  
CITY OF ROCKLIN (PUBLIC WORKS) (916) 625-5500
- ELECTRICITY &  
NATURAL GAS: PACIFIC GAS & ELECTRIC (530) 320-0149
- TELEPHONE: ATT (916) 409-1384
- CABLE T.V.: WAVE BROADBAND (916) 630-7180
- CONSOLIDATED (916) 786-1217

13. SEE INDIVIDUAL AGENCIES FOR SIZE, TYPE, AND LOCATION OF THEIR PROPOSED FACILITIES.

14. ALL OF THE ABOVE UTILITIES ARE MEMBERS OF THE "UNDERGROUND SERVICES ALERT" (U.S.A.) ONE-CALL PROGRAM. THE CONTRACTOR OR ANY SUBCONTRACTOR FOR THIS PROJECT WILL BE REQUIRED TO NOTIFY MEMBERS OF (U.S.A.) 48 HOURS IN ADVANCE OF PERFORMING EXCAVATION WORK BY CALLING 811 (PHONE 800-227-2600) OR THROUGH THE WEBSITE AT [HTTP://USANORTH811.ORG](http://USANORTH811.ORG). EXCAVATION, FOR THE PURPOSE OF THIS REQUIREMENT, IS DEFINED AS BEING 4"—6" OR MORE IN DEPTH BELOW THE EXISTING SURFACE.

**EARTHWORK AND GRADING**

1. THE CONTRACTOR SHALL CONTACT THE CITY OF ROCKLIN PUBLIC SERVICES, 48 HOURS PRIOR TO THE START OF EARTHWORK AND GRADING CONSTRUCTION.
2. GRADING SHALL NOT OCCUR ON THE PROJECT AREA UNTIL ALL EXISTING UTILITIES AND TREES AND SENSITIVE AREAS TO BE SAVED ARE ADEQUATELY PROTECTED PER THE CITY OF ROCKLIN CONSTRUCTION SPECIFICATIONS.
3. ALL COMPACTION TESTING SHALL BE PERFORMED BY THE CITY OR ITS DESIGNATED AGENT AND BE PAID FOR BY THE CITY (OR CONTRACTOR IN CASE OF RETESTING). TESTS WITHIN THE RIGHT-OF-WAY SHALL BE APPROVED BY THE CITY OF ROCKLIN AND ALL TESTS OUTSIDE THE RIGHT-OF-WAY SHALL BE CERTIFIED BY THE SOILS ENGINEER FOR THE PROJECT.

 DRAWING APPROVED – CITY ENGINEER	CITY OF ROCKLIN ENGINEERING DIVISION	
	GENERAL NOTES (SHEET 4 OF 8)	
 DRAWING APPROVED – DIRECTOR OF PUBLIC SERVICES	SCALE: NONE DATE: MAY 2016 DRAWN BY: J. PINKHAM	DWG # 1-5

ALL UNSUITABLE AND SURPLUS MATERIAL SHALL BECOME THE PROPERTY OF THE CONTRACTOR AND SHALL BE REMOVED FROM THE SITE UNLESS THE ENGINEER SPECIFIES OTHERWISE.

4. UTILITY TRENCHING TO BE COMPLETED WITH FINAL EARTHWORK. THE PROJECT WILL BE TEMPORARILY SUSPENDED PER SEC 8-1.05 FOR ALLOWING PG&E AND WAVE BROADBAND TO INSTALL THEIR RESPECTIVE FACILITIES.
5. THE CONTRACTOR SHALL AT ALL TIMES CONFORM TO THE RECOMMENDATIONS FROM THE CITY OF ROCKLIN ON DUST CONTROL, AND ANY REQUIREMENTS OF PLACER COUNTY AIR POLLUTION CONTROL DISTRICT. AREAS SURROUNDING THE WORK SHALL BE KEPT CLEAN AND RETURNED TO ORIGINAL CONDITION UPON COMPLETION OF CONTRACT. GRADING SHALL NOT OCCUR WHEN WIND SPEED EXCEEDS 10 MPH CONTINUOUSLY FOR MORE THAN 1 HOUR.
6. CONTRACTOR SHALL APPLY EROSION CONTROL HYDROSEEDING TO ALL GRADED OR DISTURBED SOILS WITHIN THE WORK AREA AFTER COMPLETION OF IMPROVEMENTS OR AS SOON AS PRACTICAL AFTER GRADING TO REDUCE DUST AND EROSION POTENTIAL. STRAW OR HYDROMULCHING SHALL BE COMBINED WITH THE SEEDING ON SLOPES EQUAL TO OR GREATER THAN 10:1 AND PLACED PRIOR TO COMPLETION OF PROJECT IF DEEMED NECESSARY FOR CONTROLLING SOIL EROSION.
7. THE CONTRACTOR SHALL DO THE FOLLOWING IF GRADING AND CLEARING IMPROVEMENTS ARE INCOMPLETE BY OCTOBER 1ST:
  - INSTALL EROSION PROTECTION ON SLOPES 10:1 OR STEEPER AND SWALES WITH SLOPES 2% OR GREATER
  - PREVENT SEDIMENT FROM LEAVING THE PROJECT AREA
  - GRADE GUTTER SAG POINTS TO DRAIN. PROVIDE FOR DRAINAGE FROM ENDS OF IMPROVEMENTS
  - PREVENT SEDIMENTATION IN EXISTING STORM DRAIN SYSTEM AND CLEAN PIPES AS PER SPECIFICATION SS62
  - SEAL OFF ALL SANITARY SEWER CONNECTIONS TO EXISTING SYSTEMS

THE CONTRACTOR SHALL MAINTAIN WINTERIZATION FACILITIES AT ALL TIMES UNTIL THE CITY ACCEPTS THE ROAD IMPROVEMENTS

8. PRIOR TO GRADING, A RAPTOR SURVEY SHALL BE DONE. NO CONSTRUCTION ACTIVITIES ARE ALLOWED WITHIN .25 MILES OF ANY IDENTIFIED RAPTOR NESTS BETWEEN THE DATES OF FEBRUARY 1<sup>ST</sup> THRU AUGUST 31<sup>ST</sup> AS APPROVED BY DIRECTOR.
9. APPROX. QUANTITY OF EARTHWORK: \_\_\_\_ CY CUT, \_\_\_\_ CY FILL

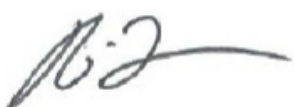
 DRAWING APPROVED – CITY ENGINEER	CITY OF ROCKLIN ENGINEERING DIVISION	
	GENERAL NOTES (SHEET 5 OF 8)	
 DRAWING APPROVED – DIRECTOR OF PUBLIC SERVICES	SCALE: NONE DATE: MAY 2016 DRAWN BY: J. PINKHAM	DWG # 1-6

10. THOSE ENGAGED IN CONSTRUCTION ACTIVITY SHALL COMPLY WITH THE CITY OF ROCKLIN CONSTRUCTION NOISE COMPATIBILITY GUIDELINES, INCLUDING RESTRICTING CONSTRUCTION NOISE GENERATING ACTIVITIES WITHIN OR NEAR RESIDENTIAL AREAS TO BETWEEN 7:00 AM AND 7:00 PM ON WEEKDAYS AND 8:00 AM AND 7:00 PM ON THE WEEKENDS TO THE SATISFACTION OF THE PUBLIC SERVICES DIRECTOR OR BUILDING OFFICIAL.

**STRIPING**



1. ALL EXISTING PAVEMENT MARKINGS TO BE REMOVED SHALL BE REMOVED BY GRINDING, AND A SURFACE TREATMENT MAY BE REQUIRED BY THE CITY.
2. ALL PAVEMENT MARKINGS SHALL BE THERMOPLASTIC AND ARE TO CONFORM TO THE MOST RECENT EDITION OF THE CALTRANS STANDARD SPECIFICATIONS AND PLANS.

**CONSTRUCTION STAKING/MONUMENTATION**

1. NO WORK SHALL COMMENCE UNTIL STAKING IS PROVIDED.
2. THE CONTRACTOR IS RESPONSIBLE FOR THE PROTECTION OF ALL MONUMENTS AND OTHER SURVEY MARKERS.
3. ALL SURVEY MONUMENTS SHALL BE SET IN ACCORDANCE WITH THE CITY OF ROCKLIN SUBDIVISION ORDINANCE PRIOR TO FINAL INSPECTION AND ACCEPTANCE OF PUBLIC IMPROVEMENTS. MONUMENT BOXES SHALL BE FROM "IRONSIDES" 1B-BODY WITH IL-LID MARKED "MONUMENT" OR APPROVED EQUAL.

**LANDSCAPING**

1. RAIN BIRD® ESP-LX SERIES COMMERCIAL CONTROLLER WITH FLOW SMART MODULE WITH LEARN FLOW UTILITY AND FLOW USAGE TOTALIZER.
2. ALL CONTROLLERS SHALL HAVE AN NCC -3G CELLULAR CARTRIDGE WITH EXTERNAL ANTENNA USED FOR DIRECT COMMUNICATION WITH THE IQ CENTRAL COMPUTER.
3. NO CO-MINGLING OF ONSITE AND CITY OF ROCKLIN IRRIGATION AND LANDSCAPE
4. ALL IRRIGATION AND LANDSCAPE SUBMITTALS SHALL BE SENT TO CITY OF ROCKLIN INSPECTOR 916-625-5577
5. ALL IRRIGATION MAINLINE AND LATERALS SHALL BE SCHEDULE 40 PVC OR GREATER. NO CLASS 200.
6. ALL BACKFLOWS SHALL BE A WILKINS 975XL INSTALLED PER PCWA SPEC WITH AN INSULATED PLACER WATER WORKS ENCLOSURE.
7. ALL IRRIGATION AND LANDSCAPE SHALL CONFORM TO THE LATEST CALIFORNIA MWEL0.

 DRAWING APPROVED – CITY ENGINEER	CITY OF ROCKLIN ENGINEERING DIVISION	
	GENERAL NOTES (SHEET 6 OF 8)	
 DRAWING APPROVED – DIRECTOR OF PUBLIC SERVICES	SCALE: NONE DATE: JUNE 2015 DRAWN BY: J. PINKHAM	DWG # 1-7

**STORM DRAINS**

STORM DRAIN REQUIREMENTS SHALL BE PER THE CITY OF ROCKLIN STANDARD SPECIFICATIONS INSTALLED PER MANUFACTURER’S RECOMMENDATIONS. MINIMUM OF 12” DIAMETER PIPE WITHIN THE CITY RIGHT OF WAY AND MINIMUM 8” DIAMETER PIPE ON PRIVATE PROPERTY.

PIPE ALTERNATIVES SHALL BE:

- CONCRETE PIPE C76 REINFORCED CONCRETE PIPE
- ASTM-12” IS SMALLEST
- ASTM-C76 CLASS 5 (UNLESS OTHERWISE SHOWN ON PLANS)
- HDPE (PER CALTRANS STANDARD, DIVISION VII, MOST RECENT EDITION)

THE CONTRACTOR SHALL MAINTAIN ALL EXISTING DRAINAGE FACILITIES WITHIN THE CONSTRUCTION AREA UNTIL NEW DRAINAGE IMPROVEMENTS ARE IN PLACE AND FUNCTIONING.

EXISTING STORM DRAIN FACILITIES SHALL BE EXPOSED AND INVERT VERIFIED PRIOR TO PLACEMENT OF PIPE. ALL CONSTRUCTION SHALL CONFORM TO MANUFACTURERS SPECIFICATIONS AND TO REQUIREMENTS OF THE CITY OF ROCKLIN STANDARD SPECIFICATIONS.

**CONFINED SPACE ENTRY (STORM DRAIN MANHOLES AND TRENCHING):**

IT IS THE PROJECT OWNER/DEVELOPER’S RESPONSIBILITY AS HOST EMPLOYER TO HAVE A CONFINED SPACE ENTRY PROGRAM IN COMPLIANCE WITH THE REQUIREMENTS OF SECTIONS 5156-5159 OF TITLE 8, GENERAL INDUSTRIAL SAFETY ORDERS, AND CALIFORNIA CODE OF REGULATIONS. CITY OF ROCKLIN EXISTING MANHOLES ARE “PERMIT REQUIRED” CONFINED SPACES. THE HOST EMPLOYER’S CONTRACTOR MUST STRICTLY CONFORM TO THE CITY OF ROCKLIN PERMIT REQUIRED CONFINED SPACE ENTRY PROGRAM IN ENTERING ANY CITY OF ROCKLIN OWNED MANHOLE. REFER TO GS7-1.06.

A “NO DUMPING” STORM DRAIN MESSAGE SHALL BE PLACED ADJACENT TO ALL DRAIN INLETS IN ACCORDANCE WITH CITY STANDARD DRAWING 4-24.

**SEWER**

CONTACT SOUTH PLACER MUNICIPAL UTILITY DISTRICT FOR REQUIRED NOTES PERTAINING TO THE SEWER SYSTEM.

**WATER**

CONTACT PLACER COUNTY WATER AGENCY FOR REQUIRED NOTES PERTAINING TO THE WATER SYSTEM.

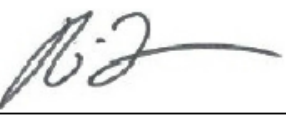
 DRAWING APPROVED – CITY ENGINEER	CITY OF ROCKLIN ENGINEERING DIVISION	
	GENERAL NOTES (SHEET 7 OF 8)	
 DRAWING APPROVED – DIRECTOR OF PUBLIC SERVICES	SCALE: NONE	DWG #
	DATE: JUNE 2015	1-8
	DRAWN BY: J. PINKHAM	

**BIOLOGICAL RESOURCES**

PRIOR TO GRADING OR CONSTRUCTION ACTIVITIES, THE OPEN SPACE/WETLAND/RIPARIAN AREAS SHALL BE FENCED WITH ORANGE CONSTRUCTION FENCING SUCH THAT THE FENCING SEPARATES THE PROJECT SITE FROM THE OPEN SPACE/WETLAND/RIPARIAN AREAS. THE FENCING SHALL BE INSTALLED TO THE SATISFACTION OF THE CITY ENGINEER AND SHALL REMAIN IN PLACE DURING ALL CONSTRUCTION ACTIVITIES.



**CULTURAL RESOURCES**

IF EVIDENCE OF ARCHEOLOGICAL OR PALEONTOLOGICAL SITE IS UNCOVERED DURING GRADING OR OTHER CONSTRUCTION ACTIVITIES, WORK SHALL BE HALTED WITHIN 100 FT OF THE FIND AND THE CITY OF ROCKLIN ENVIRONMENTAL SERVICES DIVISION SHALL BE IMMEDIATELY NOTIFIED. A QUALIFIED ARCHAEOLOGIST OR PALEONTOLOGIST SHALL BE RETAINED AT THE EXPENSE OF THE DEVELOPER/CITY TO CONDUCT AN ON-SITE EVALUATION AND PROVIDE RECOMMENDATIONS FOR REMOVAL AND/OR PRESERVATION. WORK ON THE SITE SHALL NOT RESUME UNTIL THE ARCHAEOLOGIST OR PALEONTOLOGIST HAS HAD REASONABLE TIME TO CONDUCT AN EXAMINATION AND IMPLEMENT MITIGATION MEASURES DEEMED APPROPRIATE AND NECESSARY BY THE ENVIRONMENTAL SERVICES DIVISION TO REDUCE IMPACTS TO A LESS THAN SIGNIFICANT LEVEL.

EVIDENCE OF HUMAN BURIAL OR SCATTERED HUMAN REMAINS RELATED TO PRE-HISTORIC OCCUPATION OF THE AREA COULD BE INADVERTENTLY ENCOUNTERED ANYWHERE WITHIN THE PROJECT AREA DURING CONSTRUCTION ACTIVITY OR OTHER ACTIONS INVOLVING DISTURBANCE TO THE GROUND SURFACE AND SUBSURFACE COMPONENTS. IN THE EVENT OF SUCH AN INADVERTENT DISCOVERY, WORK SHALL BE HALTED WITHIN 100 FT OF THE FIND AND THE CITY OF ROCKLIN ENVIRONMENTAL SERVICES DIVISION AND THE COUNTY CORONER SHALL BE IMMEDIATELY NOTIFIED AND CONSULTED, PER STATE LAW.

**AIR QUALITY**

PRIOR TO ANY GRADING OR CONSTRUCTION ACTIVITY, A DUST CONTROL PLAN SHALL BE SUBMITTED FOR APPROVAL BY THE CITY ENGINEER AND THE PLACER COUNTY AIR POLLUTION CONTROL DISTRICT. THE DUST CONTROL PLAN SHALL SPECIFY MEASURES TO REDUCE DUST POLLUTION DURING ALL PHASES OF CONSTRUCTION.

 DRAWING APPROVED – CITY ENGINEER	CITY OF ROCKLIN ENGINEERING DIVISION	
	GENERAL NOTES (SHEET 8 OF 8)	
 DRAWING APPROVED – DIRECTOR OF PUBLIC SERVICES	SCALE: NONE	DWG #
	DATE: JUNE 2015	1-9
	DRAWN BY: J. PINKHAM	

CITY OF ROCKLIN  
BUILDING DEPARTMENT

BUILDING DEPARTMENT PERMITS REQUIRED

A SEPARATE SUBMITTAL TO THE BUILDING DEPARTMENT IS REQUIRED PRIOR TO THE CONSTRUCTION OF THE FOLLOWING AMENITIES (Permits may be pulled individually or collectively by a class "B" General Contractor or Developer:

- RETAINING WALLS: BUILDING PERMIT FOR INSPECTION ONLY
- SITE SOUND FENCES: BUILDING PERMIT FOR INSPECTION ONLY (POST-TENSIONED DESIGNED WALLS REQUIRE A SIGNED SPECIAL INSPECTION AND TESTING AGREEMENT FORM TO BE SUBMITTED TO THE BUILDING DEPT)
- STREET LIGHT FOUNDATION & ELECTRICAL (PRIVATELY OWNED AND MAINTAINED): BUILDING PERMIT FOR PLAN REVIEW AND INSPECTION
- COMMON USE AREA AMENITIES (STRUCTURES AND ADA ACCESS COMPLIANCE): BUILDING PERMIT FOR PLAN REVIEW AND INSPECTION
- ENTRY GATE ELECTRICAL AND MECHANICAL DESIGN BUILDING PERMIT FOR REVIEW AND INSPECTION
- SITE LIGHTING ELECTRICAL DESIGN (COMMON USE AREA LIGHTING, LIGHTED BOLLARDS, ETC.): BUILDING PERMIT FOR PLAN REVIEW AND INSPECTION
- \_\_\_\_\_



DRAWING APPROVED - CITY ENGINEER



DRAWING APPROVED - DIRECTOR OF PUBLIC SERVICES

CITY OF ROCKLIN  
ENGINEERING DIVISION

BUILDING PERMIT BLOCK

SCALE: NONE  
DATE: MAY 2016  
DRAWN BY: J. PINKHAM

DWG #  
1-10

# LOT PAD CERTIFICATION

I HEREBY CERTIFY THAT I HAVE FIELD VERIFIED THE FINISHED PAD ELEVATIONS AND THEY ARE WITHIN 0.20 FT. OF THE APPROVED ELEVATIONS AS SHOWN ON THESE PLANS. DEVIATIONS OF MORE THAN 0.20 FT. ARE NOTED INSIDE <> ON ALL FOUR CORNERS OF THE PAD AS WELL AS THE CENTER OF THE PAD AS REQUIRED BY THE CITY OF ROCKLIN IMPROVEMENT STANDARDS, SECTION 9-8.

\_\_\_\_\_  
PROJECT ENGINEER

\_\_\_\_\_  
DATE

\_\_\_\_\_  
RCE # OR L.S. #



\_\_\_\_\_  
DRAWING APPROVED - CITY ENGINEER



\_\_\_\_\_  
DRAWING APPROVED - DIRECTOR OF PUBLIC SERVICES

CITY OF ROCKLIN ENGINEERING DIVISION	
LOT PAD CERTIFICATION SIGNATURE BLOCK	
SCALE: NONE	DWG #
DATE: MAY 2016	1-11
DRAWN BY: J. PINKHAM	



# RECORD DRAWING

ALL INFORMATION SHOWN ON THESE PLANS HAVE BEEN PREPARED BY, OR UNDER THE DIRECTION OF, THE UNDERSIGNED ENGINEER. ADJUSTMENTS MADE IN THE FIELD DURING CONSTRUCTION ARE INCLUDED HEREIN WHEN THE PROJECT ENGINEER IS ADVISED IN WRITING OF SUCH CHANGE BY THE OWNER, DEVELOPER, CONTRACTOR OR THE CITY OF ROCKLIN.

\_\_\_\_\_  
PROJECT ENGINEER

\_\_\_\_\_  
DATE

\_\_\_\_\_  
RCE #



\_\_\_\_\_  
DRAWING APPROVED – CITY ENGINEER



\_\_\_\_\_  
DRAWING APPROVED – DIRECTOR OF PUBLIC SERVICES

CITY OF ROCKLIN ENGINEERING DIVISION	
RECORD DRAWING SIGNATURE BLOCK	
SCALE: NONE	DWG #
DATE: AUGUST 2016	1-12
DRAWN BY: J. PINKHAM	

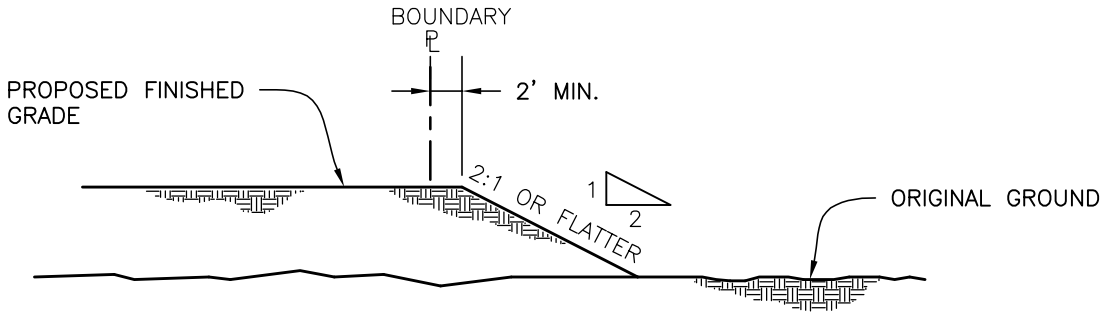

MOST DESIRABLE

1. A NOTARIZED RIGHT OF ENTRY IS REQUIRED FROM ADJACENT PROPERTY OWNER.

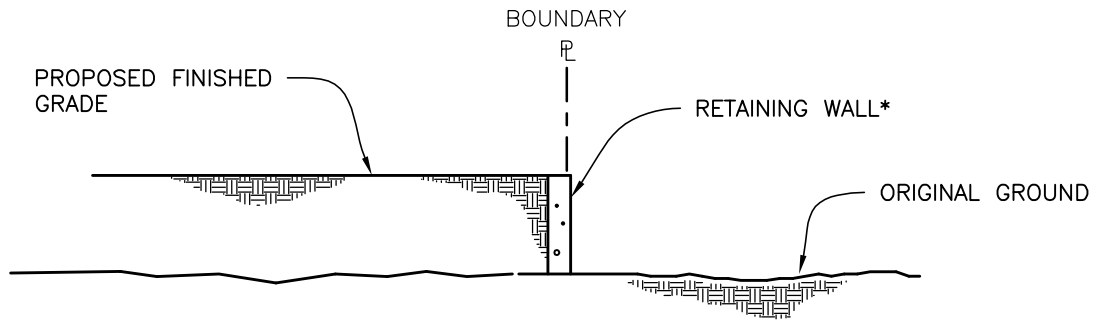

\* ENTIRE WALL INCLUDING FOUNDATION SHALL BE LOCATED ON PRIVATE PROPERTY AND BE CONSTRUCTED WITH CONCRETE OR MASONRY BLOCK IF 24" OR GREATER IN HEIGHT.

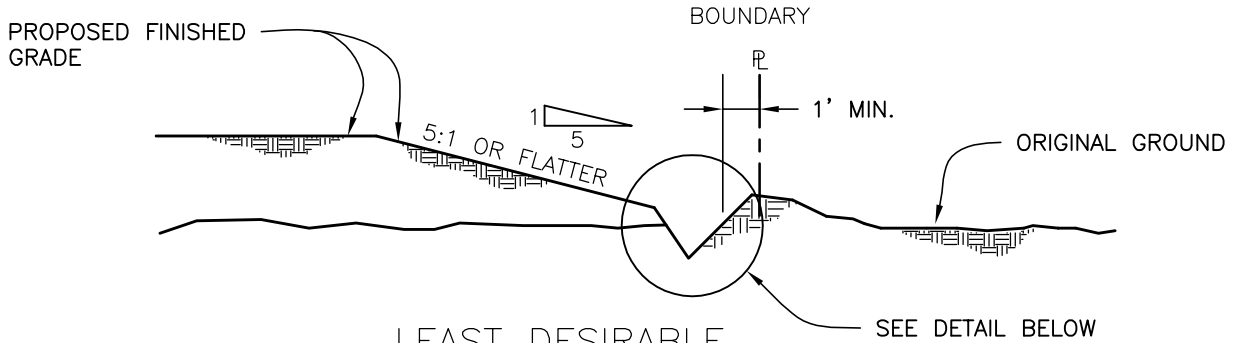

LEAST DESIRABLE

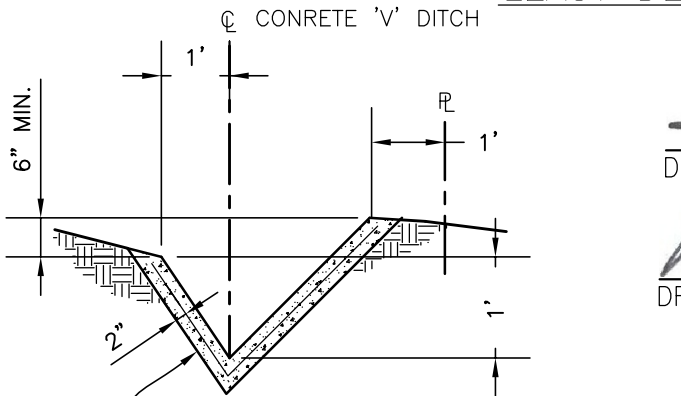

4" MIN. GUNNITE OR CONCRETE W/ 6"X6"X2.1"X2.1" SHEET WELDED WIRE MESH. GROUTED COBBLE DITCH ACCEPTABLE UPON APPROVAL FROM THE CITY ENGINEER

"V" DITCH DETAIL

*[Signature]*

DRAWING APPROVED - CITY ENGINEER

*[Signature]*

DRAWING APPROVED - DIRECTOR OF PUBLIC SERVICES

<b>CITY OF ROCKLIN ENGINEERING DIVISION</b>	
EXTERIOR PERIMETER PROPERTY LINE GRADING	
<b>SCALE: NONE</b> <b>DATE: JULY 2015</b> <b>DRAWN BY: J. PINKHAM</b>	<b>DWG #</b> 2-1

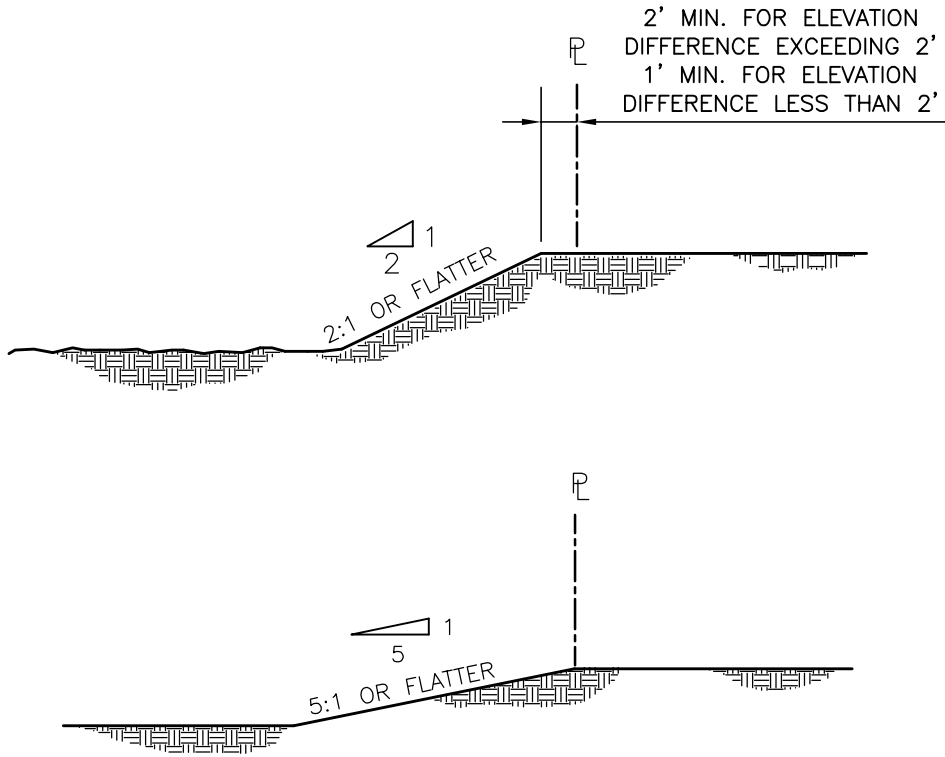

### CUT BANKS

1. A NOTARIZED RIGHT OF ENTRY IS REQUIRED FROM ADJACENT PROPERTY OWNER.

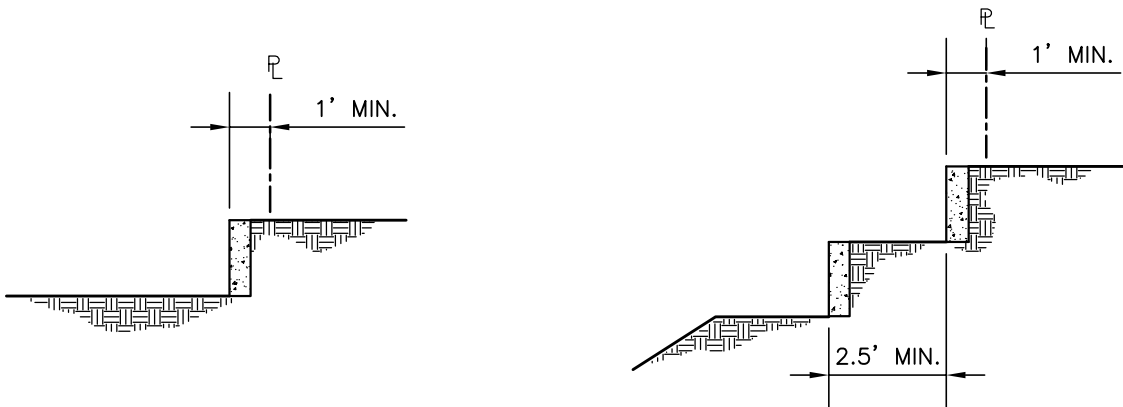

### RETAINING WALLS

NOTE:

1. USE FOR CUTS ADJACENT TO BOUNDARY OR EXTERIOR PERIMETER PROPERTY LINES.
2. NO DOUBLE RETAINING WALLS TO BE CONSTRUCTED ON SIDE YARDS FOR LOTS TO BE IN CONFORMANCE TO FHA STANDARDS

*[Signature]*

DRAWING APPROVED – CITY ENGINEER

*[Signature]*

DRAWING APPROVED – DIRECTOR OF PUBLIC SERVICES

CITY OF ROCKLIN  
ENGINEERING DIVISION

INTERIOR  
PROPERTY LINE  
GRADING

SCALE: NONE  
DATE: JULY 2015  
DRAWN BY: J. PINKHAM

DWG #  
2-2

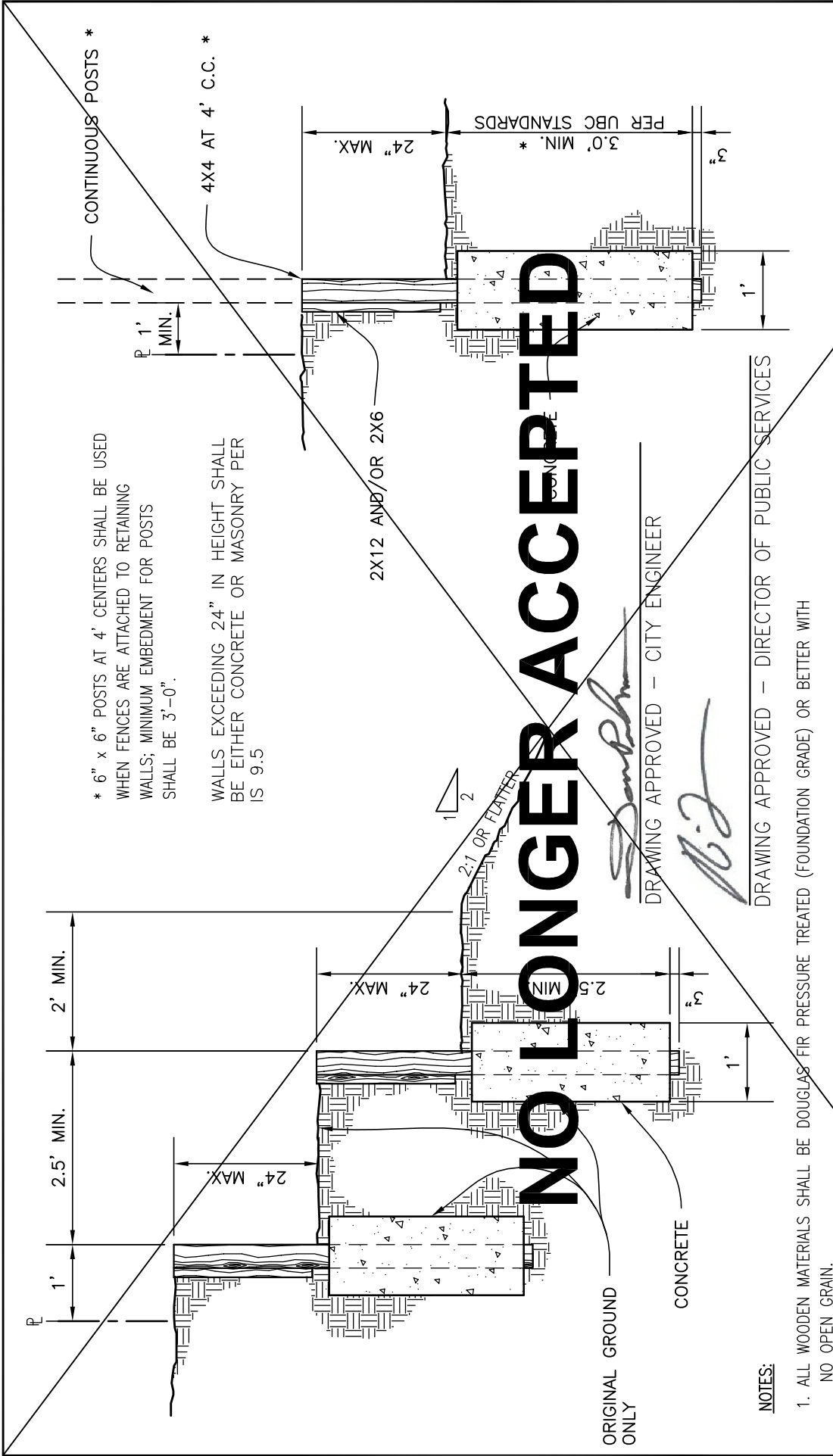

\* 6" x 6" POSTS AT 4' CENTERS SHALL BE USED WHEN FENCES ARE ATTACHED TO RETAINING WALLS; MINIMUM EMBEDMENT FOR POSTS SHALL BE 3'-0".

WALLS EXCEEDING 24" IN HEIGHT SHALL BE EITHER CONCRETE OR MASONRY PER IS 9.5

2X12 AND/OR 2X6

1  
2  
2:1 OR FLATTER

**NO LONGER ACCEPTED**

ORIGINAL GROUND ONLY

CONCRETE

**NOTES:**

1. ALL WOODEN MATERIALS SHALL BE DOUGLAS FIR PRESSURE TREATED (FOUNDATION GRADE) OR BETTER WITH NO OPEN GRAIN.
2. WOODEN WALLS SHALL NOT BE USED ADJACENT TO STREET RIGHT OF WAYS.
3. CONCRETE, CONCRETE BLOCK AND OTHER WALL DETAILS TO BE DETERMINED ON INDIVIDUAL BASIS AND IN CONFORMANCE TO STATE STANDARD DRAWINGS FOR RETAINING WALL CONSTRUCTION.
4. A BUILDING PERMIT SHALL BE OBTAINED FOR ALL RETAINING WALLS EXCEEDING 30 INCHES IN HEIGHT, WHEN CONSTRUCTION DETAILS ARE NOT SHOWN ON APPROVED IMPROVEMENT PLANS.
5. A BUILDING PERMIT SHALL BE REQUIRED FOR ALL PROPERTY LINE RETAINING WALLS WHEN A FENCE IS AN INTEGRAL PART OF THE WALL AND THE CONSTRUCTION DETAILS ARE NOT SHOWN ON APPROVED IMPROVEMENT PLANS.

DRAWING APPROVED - CITY ENGINEER

DRAWING APPROVED - DIRECTOR OF PUBLIC SERVICES

CITY OF ROCKLIN ENGINEERING DIVISION	
REDWOOD	
RETAINING WALL DETAILS	
SCALE: NONE	DWG #
DATE: MAY 2016	2-3
DRAWN BY: J. PINKHAM	

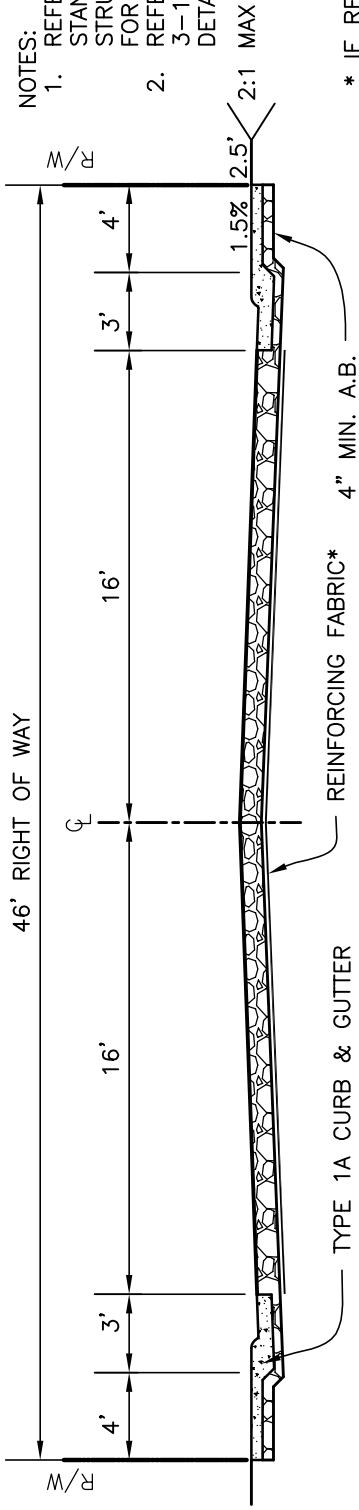

**MINOR STREET**  
N.T.S.

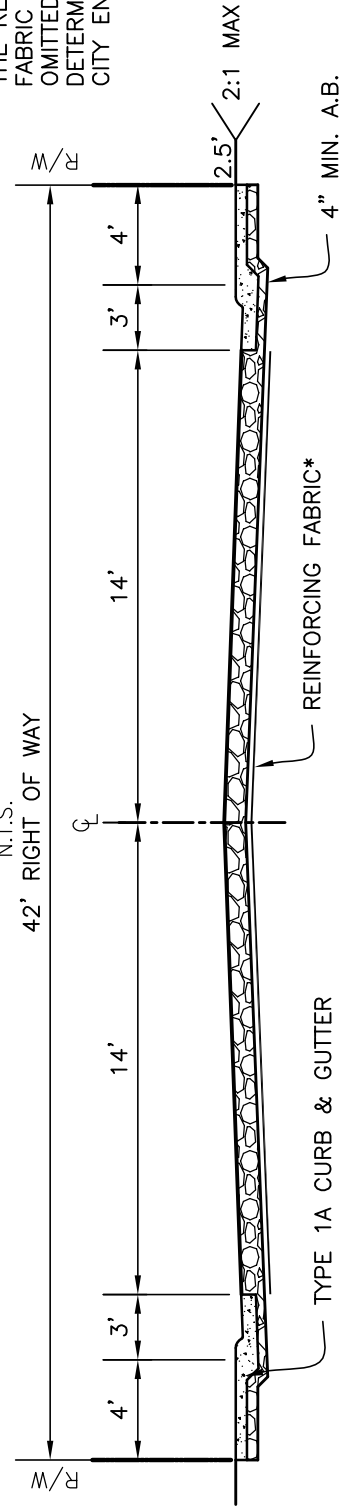

**CUL-DE-SAC**  
N.T.S.

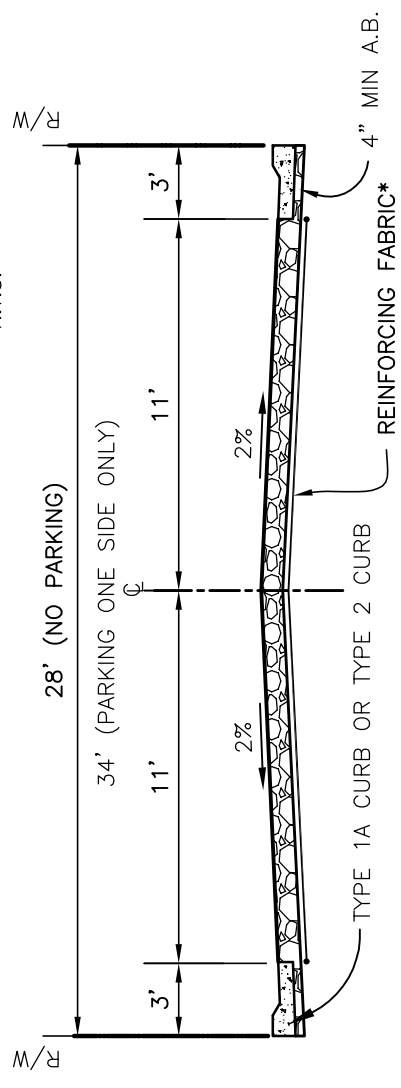

**TYPE P.D.**  
N.T.S.

(NON-DEDICATED STREET PLANNED DEVELOPMENT)  
N.T.S.

- NOTES:
1. REFER TO IMPROV. STANDARDS 4-3 FOR STRUCTURAL SECTION FOR AC & AB
  2. REFER TO DETAIL 3-15 FOR SIDEWALK DETAILS

\* IF RECOMMENDED BY GEOTECHNICAL ENGINEERING REPORT THE REINFORCING FABRIC MAY BE OMITTED AS DETERMINED BY THE CITY ENGINEER.

*[Signature]*  
DRAWING APPROVED - CITY ENGINEER

*[Signature]*  
DRAWING APPROVED - DIRECTOR OF PUBLIC SERVICES

<b>CITY OF ROCKLIN ENGINEERING DIVISION</b>	
TYPICAL SECTIONS	
RESIDENTIAL STREETS	
SCALE: NONE	DWG # 3-1
DATE: JULY 2015	
DRAWN BY: J. PINKHAM	

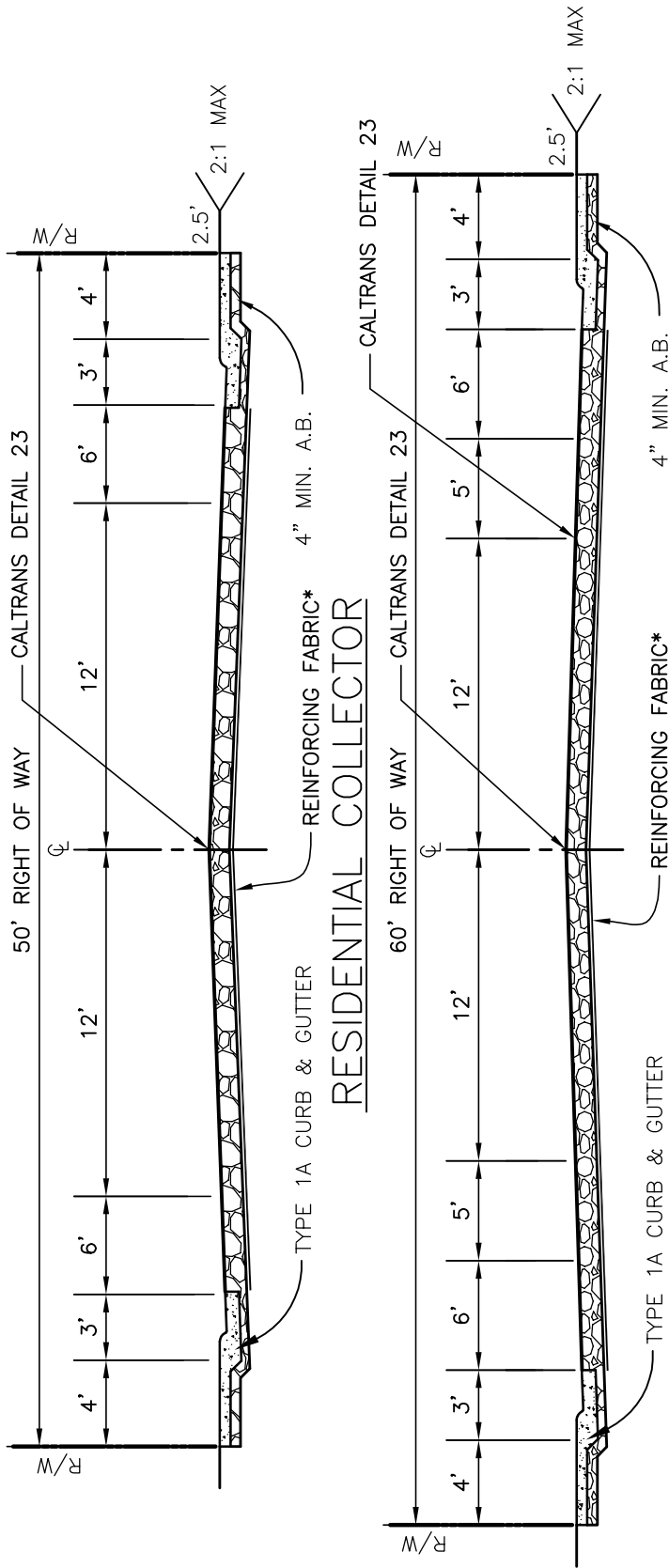

\* IF RECOMMENDED BY GEOTECHNICAL ENGINEERING REPORT THE REINFORCING FABRIC MAY BE OMITTED AS DETERMINED BY THE CITY ENGINEER.

NOTES:

1. PAVEMENT SECTION TO BE AC ON AB. REFER TO SECTION I.S. 4-3 OF THE DESIGN STANDARDS FOR STREET PAVEMENT REQUIREMENTS.
2. REFER TO DETAIL 3-15 FOR SIDEWALK DETAILS.
3. ON INDUSTRIAL STREETS THE CENTER TWO WAY LEFT TURN (DETAIL 33) SHALL BE REPLACED BY A DETAIL "23" (CALTRANS) CENTERLINE STRIPING AND TURN LANES AS MAY BE REQUIRED. NO BIKE LANES ARE REQUIRED.
4. CURB AND GUTTER SHALL BE "TYPE 2" (3-15) AND SIDEWALK TO HAVE 6" THICK CONCRETE WITH 6" COMPACTED AGGREGATE BASE.
5. STRIPING DETAIL NUMBERS REFERENCE CALTRANS STANDARDS
6. P.U.E./T.C.E. — PUBLIC UTILITY EASEMENT / TRAFFIC CONTROL EASEMENT.
7. "NO PARKING" (R-26) SIGNS SHALL BE PLACED ON STREET LIGHT POLES WHERE BIKE LANES EXIST OR AS DIRECTED BY CITY ENGINEER.
8. SIGN DETAIL NUMBERS REFERENCE 2012 MUTCD
9. IN CERTAIN INSTANCES, WITH THE RECOMMENDATION OF THE PUBLIC WORKS DIRECTOR, AND APPROVAL OF CITY COUNCIL, THIS ROADWAY STANDARD MAY BE MODIFIED WITH THE DEMONSTRATION THAT "BLUEPRINT" GOALS AND OBJECTIVES OF A WALKABLE COMMUNITY ARE BEING ACHIEVED WITHIN A COMMUNITY PLAN.

DRAWING APPROVED — CITY ENGINEER

*[Signature]*

*[Signature]*

DRAWING APPROVED — DIRECTOR OF PUBLIC SERVICES

CITY OF ROCKLIN ENGINEERING DIVISION	
TYPICAL SECTIONS	
RESIDENTIAL COLLECTOR STREETS	
SCALE: NONE	DWG #
DATE: DECEMBER 2015	3-2
DRAWN BY: J. PINKHAM	

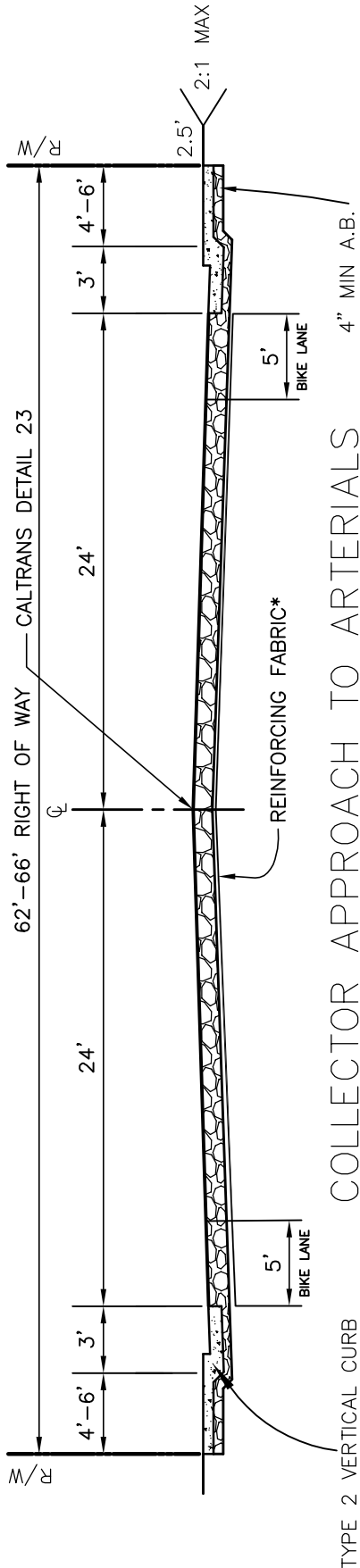
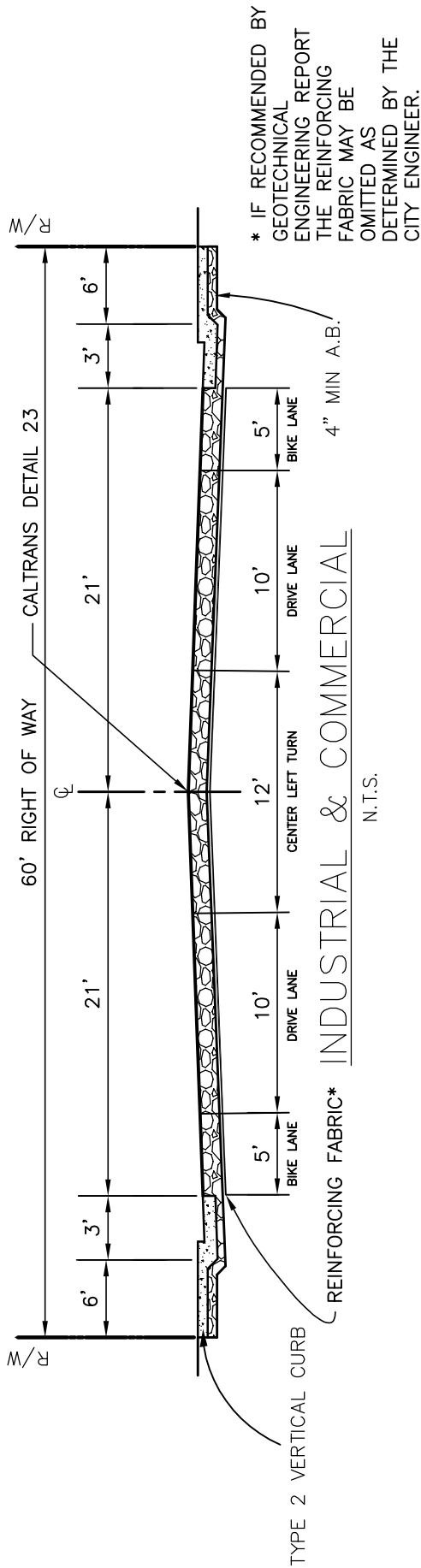

COLLECTOR APPROACH TO ARTERIALS

CITY OF ROCKLIN ENGINEERING DIVISION	
TYPICAL SECTIONS—INDUSTRIAL & COMMERCIAL / COLLECTOR APPROACH TO ARTERIALS	
SCALE: NONE	DWG #
DATE: 05/10/16	3-3
DRAWN BY: J.PINKHAM	

  
 DRAWING APPROVED — CITY ENGINEER  
  
 DRAWING APPROVED — DIRECTOR OF PUBLIC SERVICES

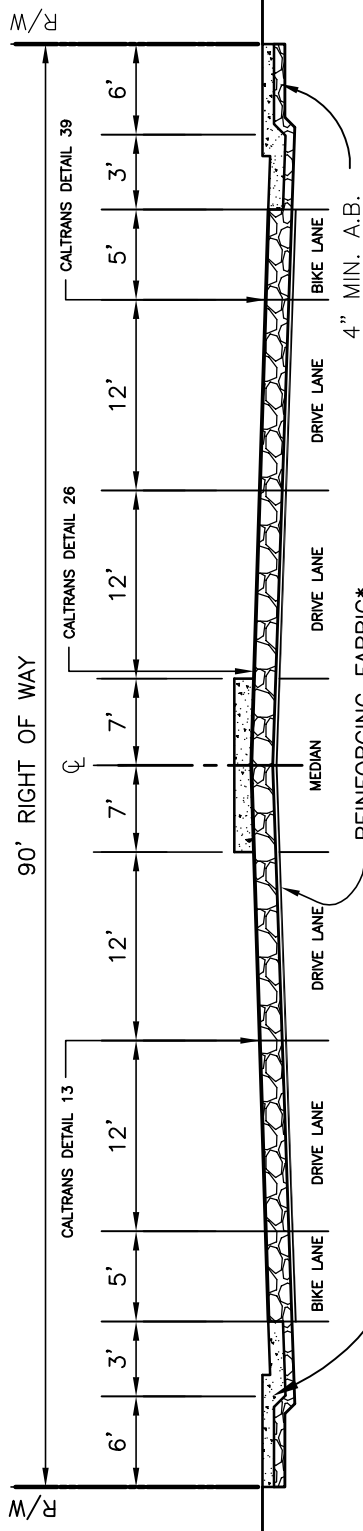

**MINOR ARTERIAL**  
 (WITH BIKE LANES AND MEDIAN)  
 N.T.S.

\* IF RECOMMENDED BY  
 GEOTECHNICAL  
 ENGINEERING REPORT  
 THE REINFORCING  
 FABRIC MAY BE  
 OMITTED AS  
 DETERMINED BY THE  
 CITY ENGINEER.

CITY OF ROCKLIN ENGINEERING DIVISION	
TYPICAL SECTIONS MINOR ARTERIAL STREETS	
SCALE: NONE	DWG #
DATE: JULY 2015	3-4
DRAWN BY: J. PINKHAM	

*[Signature]*  
 DRAWING APPROVED - CITY ENGINEER

*[Signature]*  
 DRAWING APPROVED - DIRECTOR OF PUBLIC SERVICES



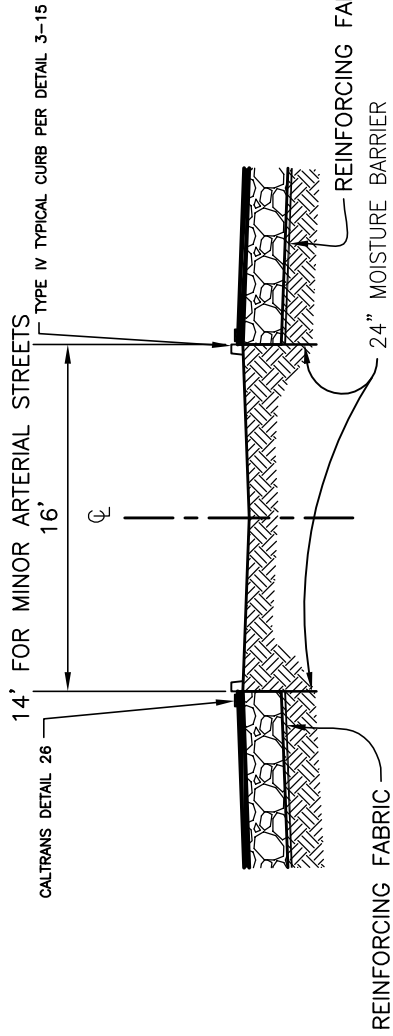

\* IF RECOMMENDED BY GEOTECHNICAL ENGINEERING REPORT THE REINFORCING FABRIC MAY BE OMITTED AS DETERMINED BY THE CITY ENGINEER.

ALTERNATE MEDIAN  
N.T.S.

SEE IS 4-3 FOR STRUCTURAL STREET SECTION

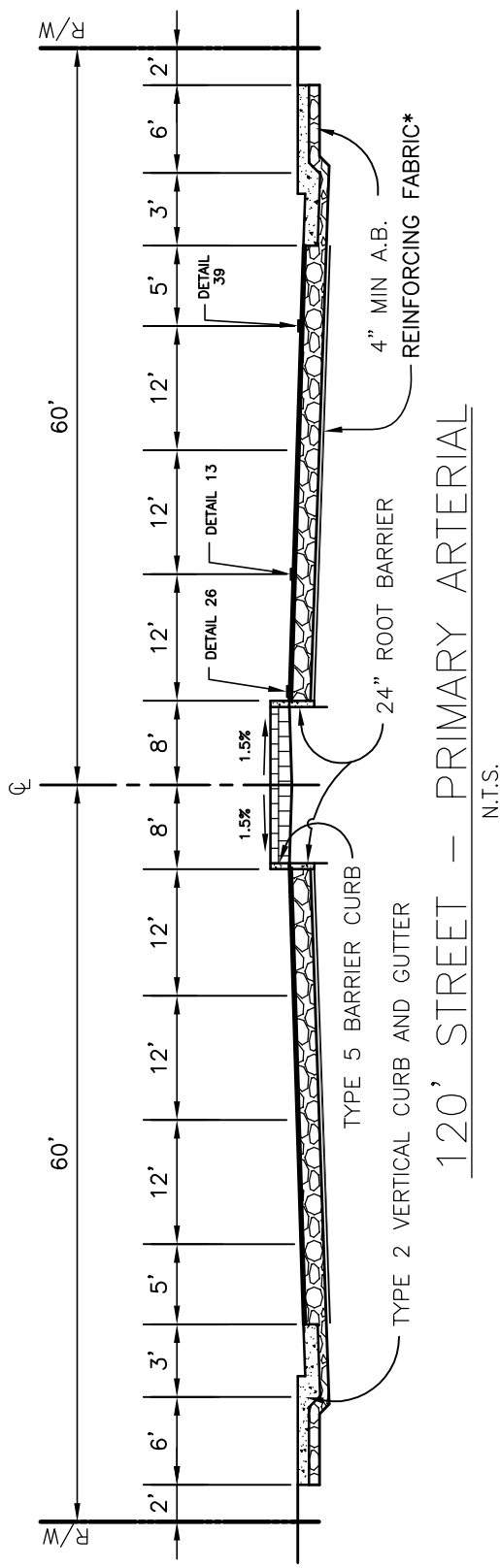

120' STREET - PRIMARY ARTERIAL  
N.T.S.

CITY OF ROCKLIN ENGINEERING DIVISION TYPICAL SECTIONS PRIMARY ARTERIAL STREETS	
SCALE: NONE	DWG # 3-5
DATE: DECEMBER 2015	
DRAWN BY: J. PINKHAM	

*[Signature]*  
DRAWING APPROVED - CITY ENGINEER

*[Signature]*  
DRAWING APPROVED - DIRECTOR OF PUBLIC SERVICES

REFER TO IS 4-3 SPECIFICATIONS FOR  
STRUCTURAL SECTION OF AB AND AC

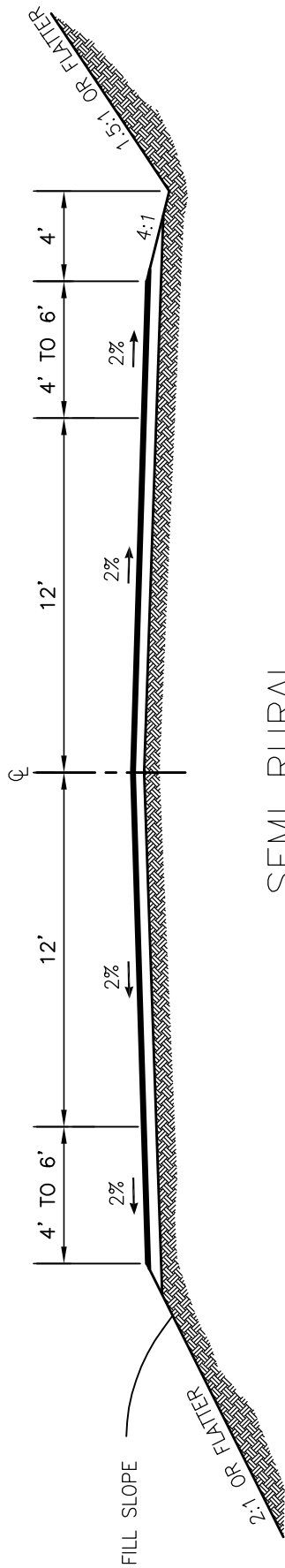

SEMI RURAL  
N.T.S.

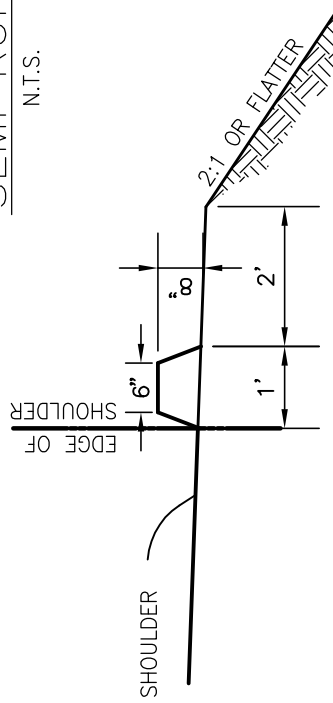

SHOULDER WIDENING  
WITH A.C. DIKE  
N.T.S.

CITY OF ROCKLIN ENGINEERING DIVISION		DWG # 3-6A
TYPICAL SECTIONS SEMI RURAL		SCALE: NONE DATE: MAY 2016 DRAWN BY: J.PINKHAM

*[Signature]*  
DRAWING APPROVED - CITY ENGINEER

*[Signature]*  
DRAWING APPROVED - DIRECTOR OF PUBLIC SERVICES

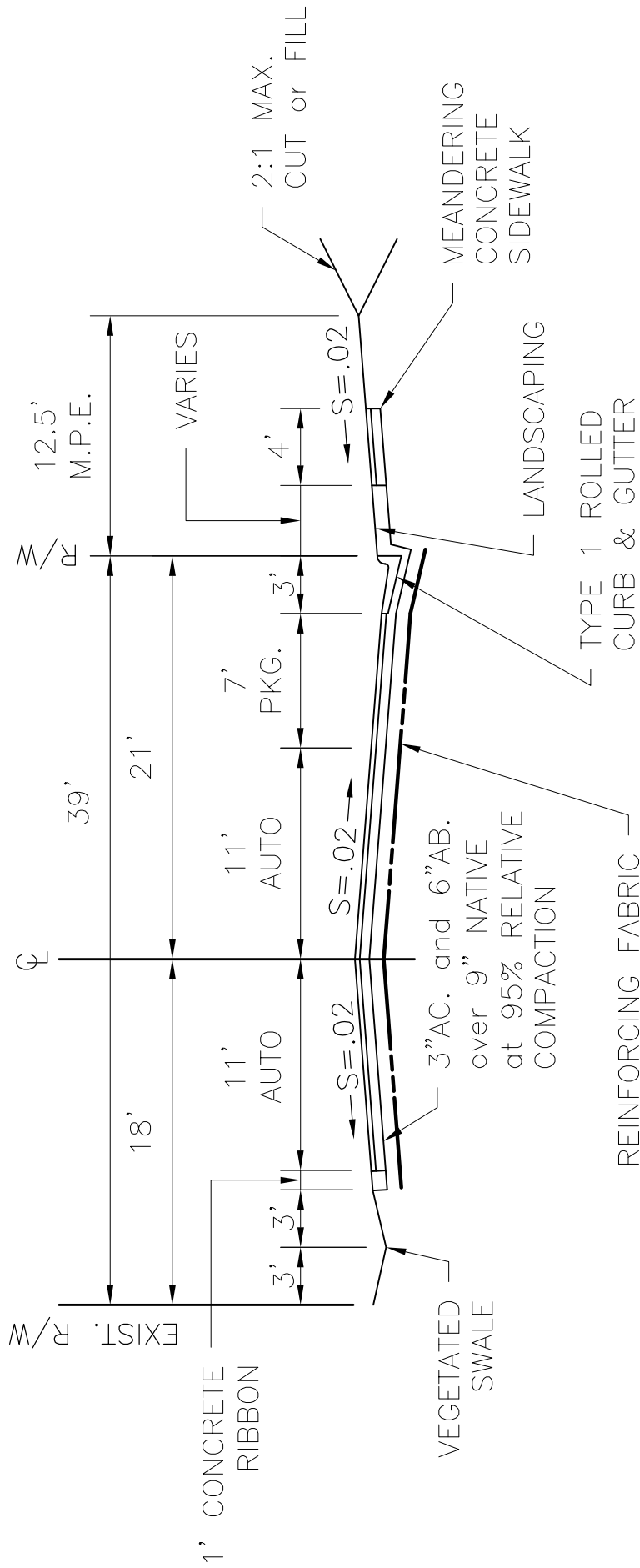

<b>CITY OF ROCKLIN ENGINEERING DIVISION</b>	
IMPROVED STREET WITH VEGETATED SWALE	
SCALE: NONE	DWG # 3-6B
DATE: MAY 2016	
DRAWN BY: J.PINKHAM	

*[Signature]*  
DRAWING APPROVED - CITY ENGINEER

*[Signature]*  
DRAWING APPROVED - DIRECTOR OF PUBLIC SERVICES

**RADI REQUIREMENTS:**

STREET R/W WIDTH	(R)
42'	42'
46'	46'
50'	50'
60'	60'

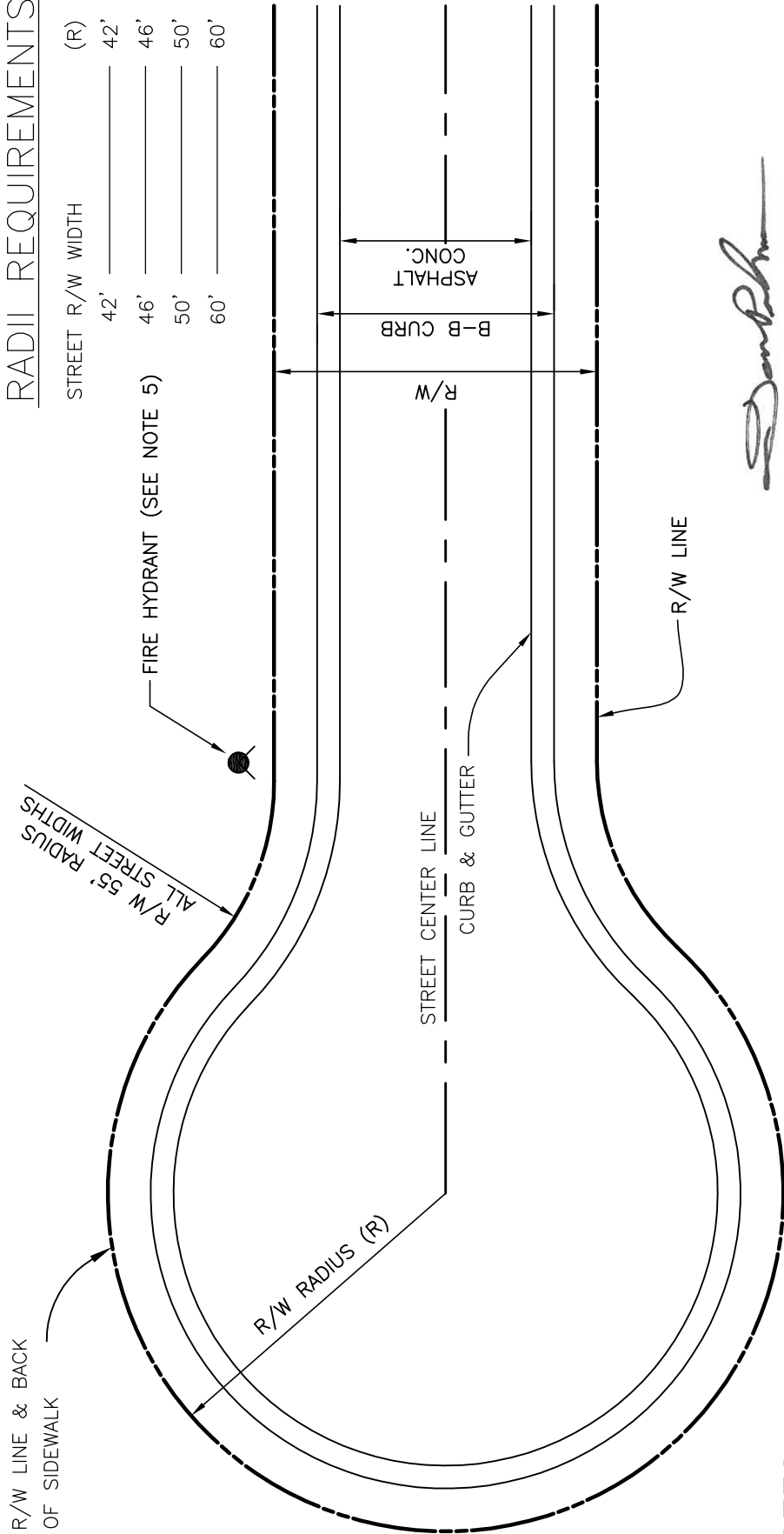

**NOTES:**

1. A STANDARD CODE W53 (NOT A THROUGH STREET) SIGN IS TO BE POSTED AT THE ENTRANCE TO ALL CUL-DE-SACS SERVING MORE THAN TWELVE RESIDENCES. SEE CALTRANS W-53
2. A STANDARD CODE W53 (NOT A THROUGH STREET) SIGN IS TO BE INSTALLED AT THE ENTRANCE OF A CUL-DE-SAC WHEN THE CUL-DE-SAC IS AT THE PROLONGATION OF EITHER A STREET, DRIVE OR WAY.
3. A STANDARD CODE W53 (NOT A THROUGH STREET) SIGN IS TO BE INSTALLED AT THE ENTRANCE OF A CUL-DE-SAC WHEN THE CUL-DE-SAC HAS A CURVILINEAR ALIGNMENT AND OBSTRUCTED TERMINUS, REGARDLESS OF LENGTH.
4. A STANDARD CODE W53 (NOT A THROUGH STREET) SIGN IS TO BE INSTALLED AT THE ENTRANCE OF A CUL-DE-SAC WHEN THE LENGTH OF THE CUL-DE-SAC EXCEEDS 600 FEET. LENGTH OF CUL-DE-SAC STREETS SHALL BE MEASURED FROM CENTER OF BULB TO CENTERLINE OF EXISTING STREET.
5. ALL CUL-DE-SACS IN EXCESS OF 200' SHALL HAVE A FIRE HYDRANT INSTALLED AT THE BULB. SUBJECT TO THE APPROVAL OF THE FIRE DEPARTMENT.

DRAWING APPROVED -- CITY ENGINEER

DRAWING APPROVED -- DIRECTOR OF PUBLIC SERVICES

<b>CITY OF ROCKLIN ENGINEERING DIVISION</b>	
CUL-DE-SAC	
SCALE: NONE	DWG #
DATE: MARCH 2006	3-7
DRAWN BY: J. PINKHAM	

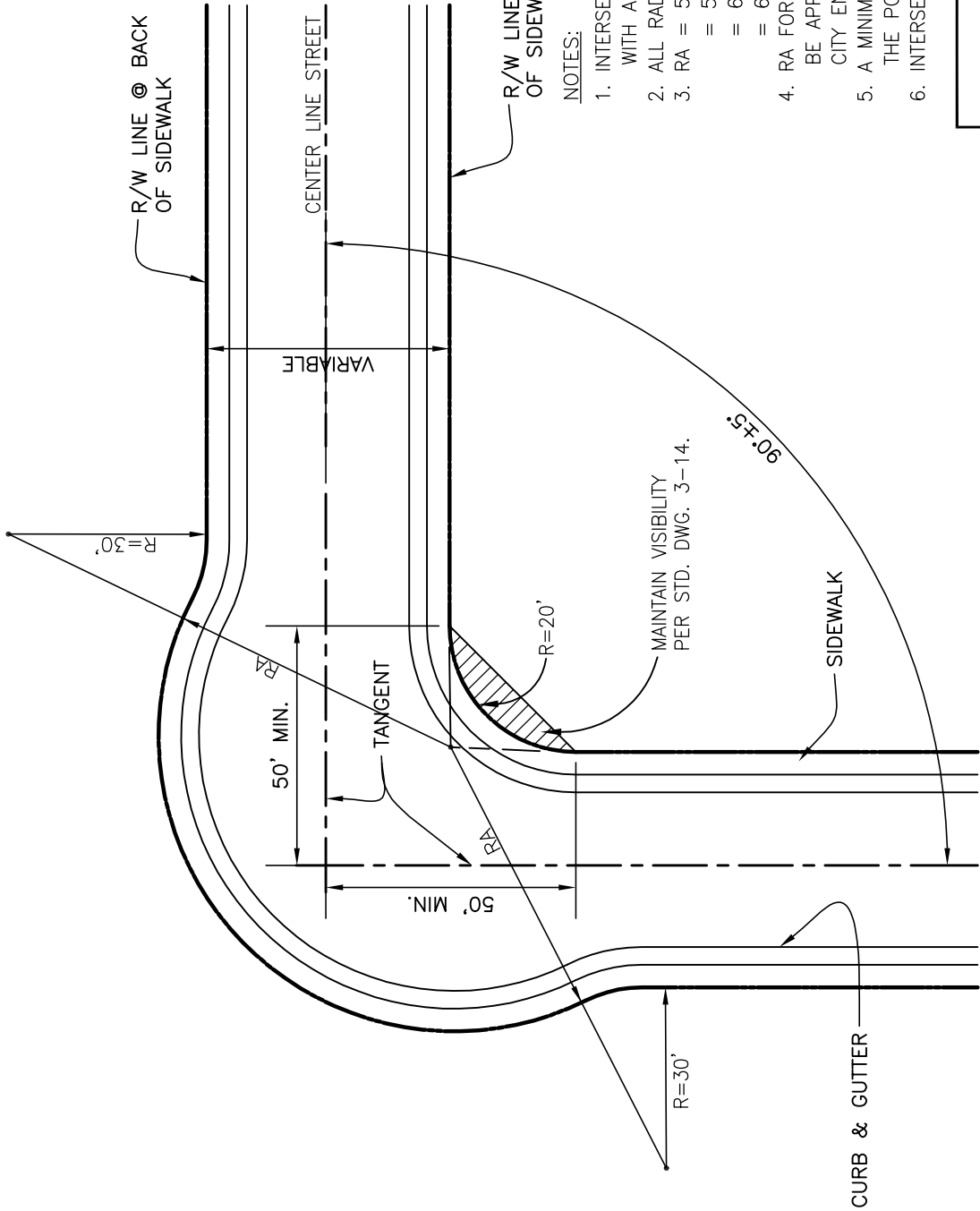

**NOTES:**

1. INTERSECTION BULBS ARE NOT REQUIRED ON STREETS WITH A CENTERLINE RADIUS OF 200' OR MORE.
2. ALL RADII SHOWN PERTAIN TO R/W LINES
3. RA = 50' ON 42' STREETS  
= 56' ON 46' STREETS  
= 60' ON 50' STREETS  
= 68' ON 60' STREETS
4. RA FOR STREETS W/ R/W GREATER THAN 60' SHALL BE APPROVED ON A CASE BY CASE BASIS BY THE CITY ENGINEER.
5. A MINIMUM OF 50' OF TANGENT IS REQUIRED FROM THE POINT OF INTERSECTION OF THE CENTERLINES.
6. INTERSECTION ANGLE SHALL BE  $90 \pm 5'$

<b>CITY OF ROCKKLIN ENGINEERING DIVISION</b>	
<b>90° INTERSECTION ELBOW</b>	
<b>SCALE:</b> NONE	<b>DWG #</b> 3-8
<b>DATE:</b> MARCH 2006	
<b>DRAWN BY:</b> J. PINKHAM	

  
 DRAWING APPROVED - CITY ENGINEER



  
 DRAWING APPROVED - DIRECTOR OF PUBLIC SERVICES

NOTES:

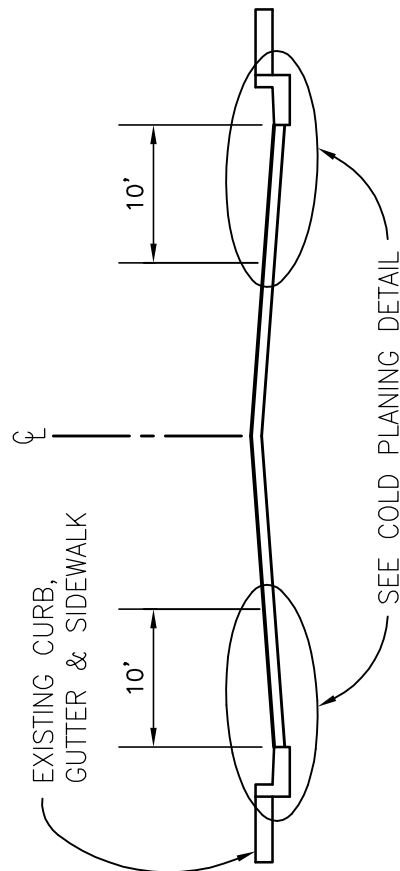
1. BLOCK MANHOLE FRAME TO GRADE WITH GRADE RINGS WITHIN 2" BLOCK. POUR CLASS 'B' CONCRETE TO 2" BELOW FINISH GRADE OF NEW PAVEMENT. FINISH INSIDE TO SMOOTH SURFACE.
2. COMPLETE TO GRADE WITH 2" ASPHALT CONCRETE. SMALL CASTINGS TO BE RAISED IN SIMILAR MANNER.

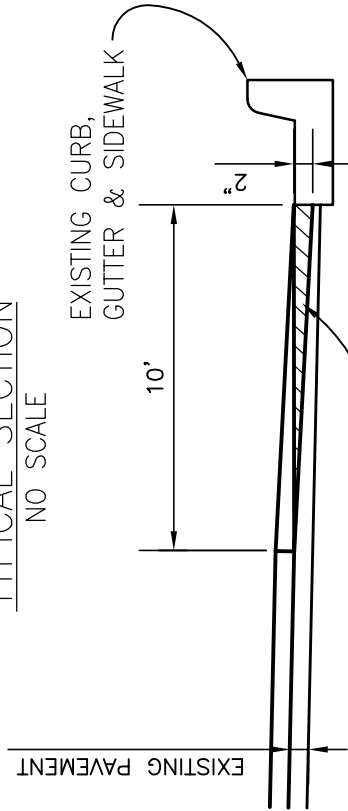

TYPICAL SECTION  
NO SCALE



COLD PLANING @ 2" BELOW LIP OF GUTTER

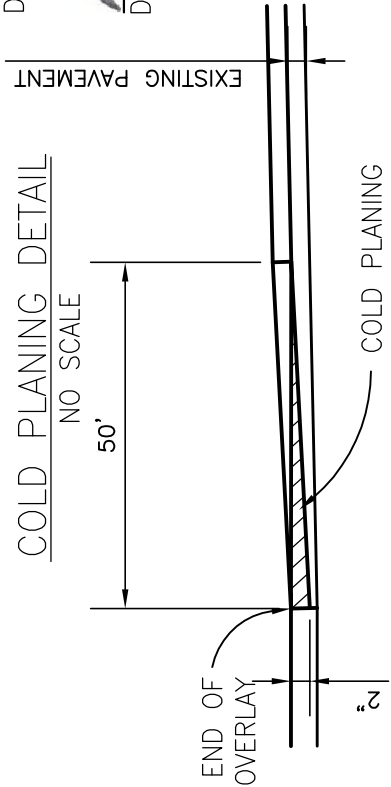

END OF OVERLAY DETAIL  
NO SCALE

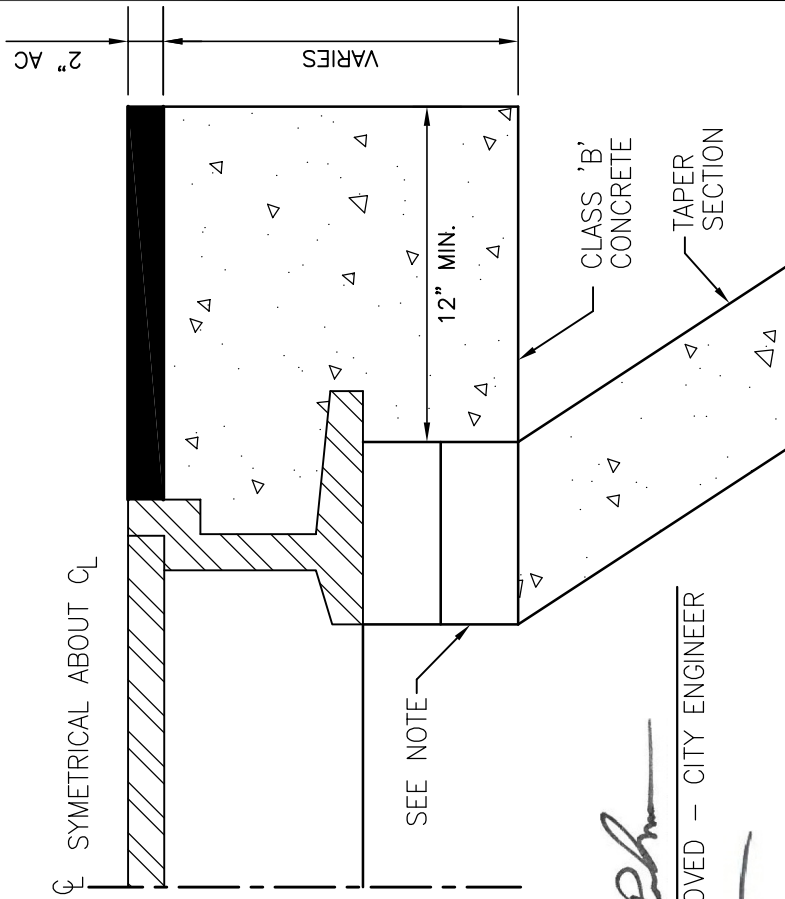

SEE NOTE

*[Signature]*  
DRAWING APPROVED - CITY ENGINEER

*[Signature]*  
DRAWING APPROVED - DIRECTOR OF PUBLIC SERVICES

<b>CITY OF ROCKLIN ENGINEERING DIVISION</b>	
<b>STANDARD CASTING ADJUSTING DETAIL AND COLD PLANING DETAIL OF EXISTING STREETS</b>	
SCALE: NONE	DWG # 3-9
DATE: JULY 2015	
DRAWN BY: J. PINKHAM	

## BUS TURNOUT ON 120 FOOT STREETS

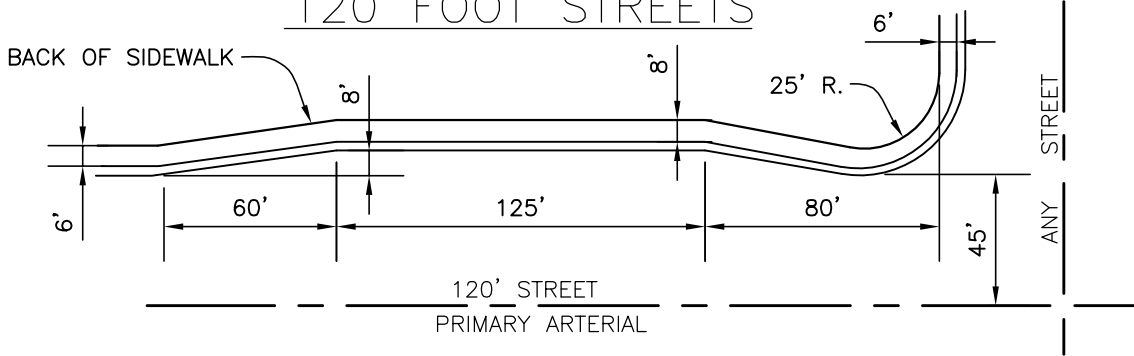

## BUS TURNOUT ON 80 & 90 FOOT STREETS

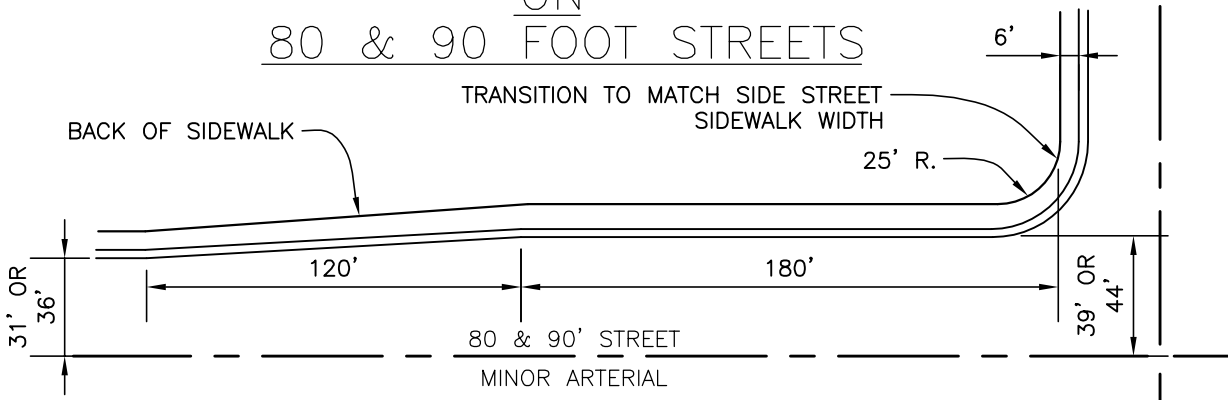

## TYPICAL MID-BLOCK BUS TURNOUT

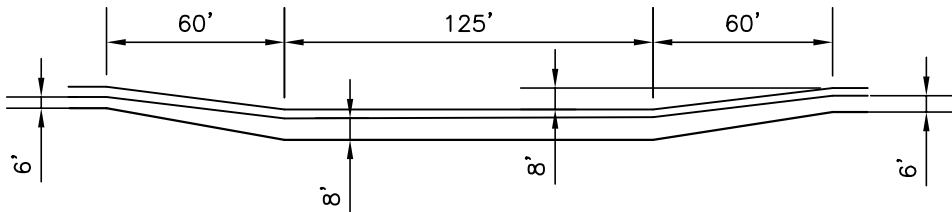

**NOTE:**  
BUS STOPS AT INTERSECTIONS OF 80' STREETS  
WITH 80'/90'/120' CROSS STREETS ARE PROVIDED  
FOR BY STANDARD INTERSECTION WIDENING.

*[Signature]*  
DRAWING APPROVED - CITY ENGINEER

*[Signature]*  
DRAWING APPROVED - DIRECTOR OF PUBLIC SERVICES

<b>CITY OF ROCKLIN ENGINEERING DIVISION</b>	
<b>BUS TURNOUT</b>	
<b>SCALE: NONE</b>	<b>DWG #</b>
<b>DATE: JULY 2015</b>	<b>3-10</b>
<b>DRAWN BY: J. PINKHAM</b>	

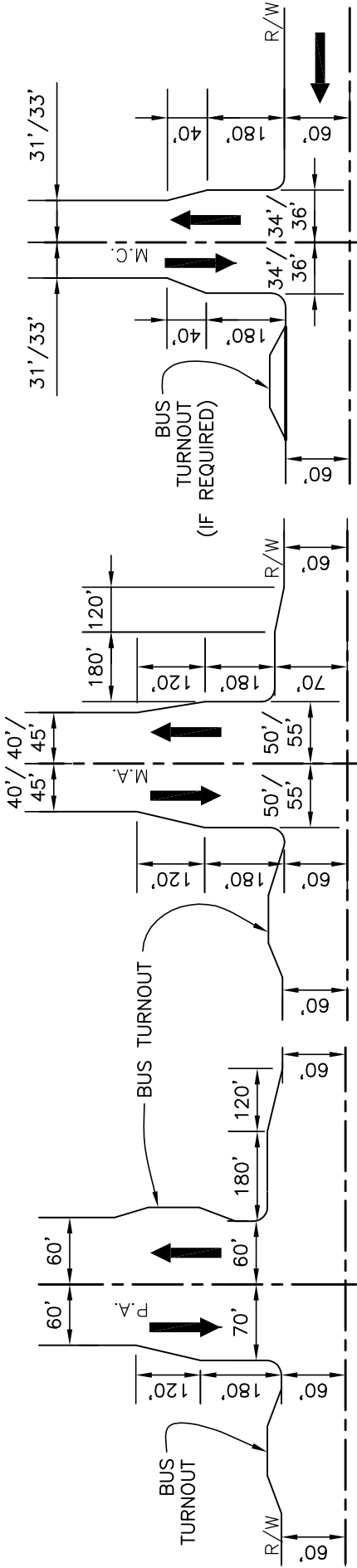

(PRIMARY ARTERIAL) 120' STREET

DIRECTION OF TRAFFIC →

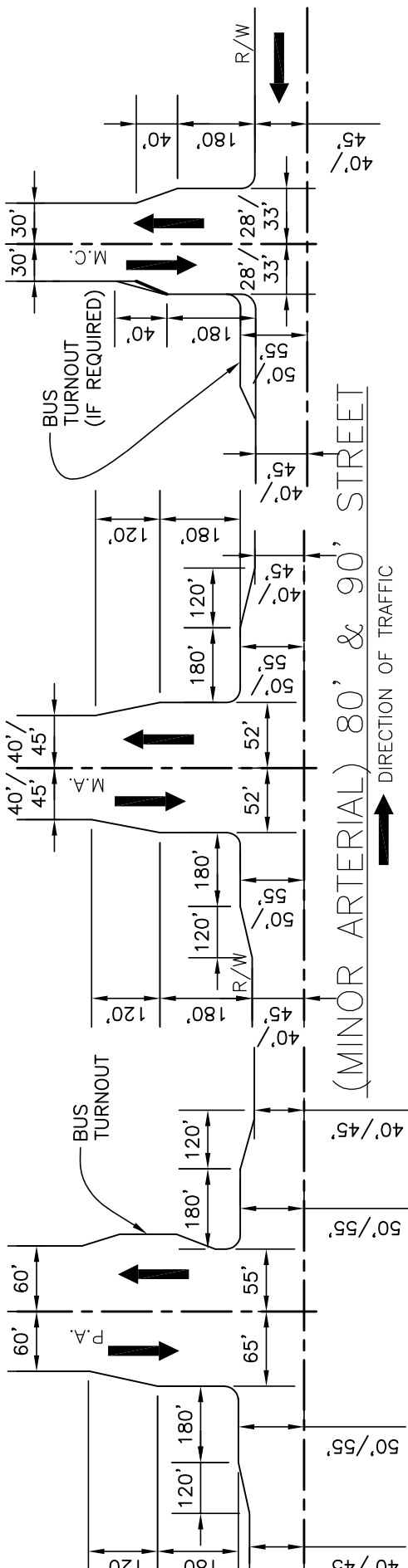

(MINOR ARTERIAL) 80' & 90' STREET

DIRECTION OF TRAFFIC →

NOTES:

1. USE 100' PAVEMENT TAPER SECTION WHEN MAJOR STREET SHOULDER IS UNPAVED OR SEAL COATED. R=25' AT ALL INTERSECTIONS.
2. USE 67' PAVEMENT TAPER SECTION WHEN MAJOR STREET SHOULDER IS FULLY PAVED.
3. FULL ROADBED STRUCTURAL SECTION TO BE PLACED IN ACCORDANCE WITH CITY STANDARDS FOR AREA TO BE PAVED.

*[Signature]*  
DRAWING APPROVED - CITY ENGINEER

*[Signature]*

CITY OF ROCKLIN  
ENGINEERING DIVISION  
WIDENING DETAILS  
AT MAJOR STREET  
INTERSECTIONS

SCALE: NONE DATE: JULY 2015 DRAWN BY: J. PINKHAM	DWG # 3-11
--	---------------

DRAWING APPROVED - DIRECTOR OF PUBLIC SERVICES



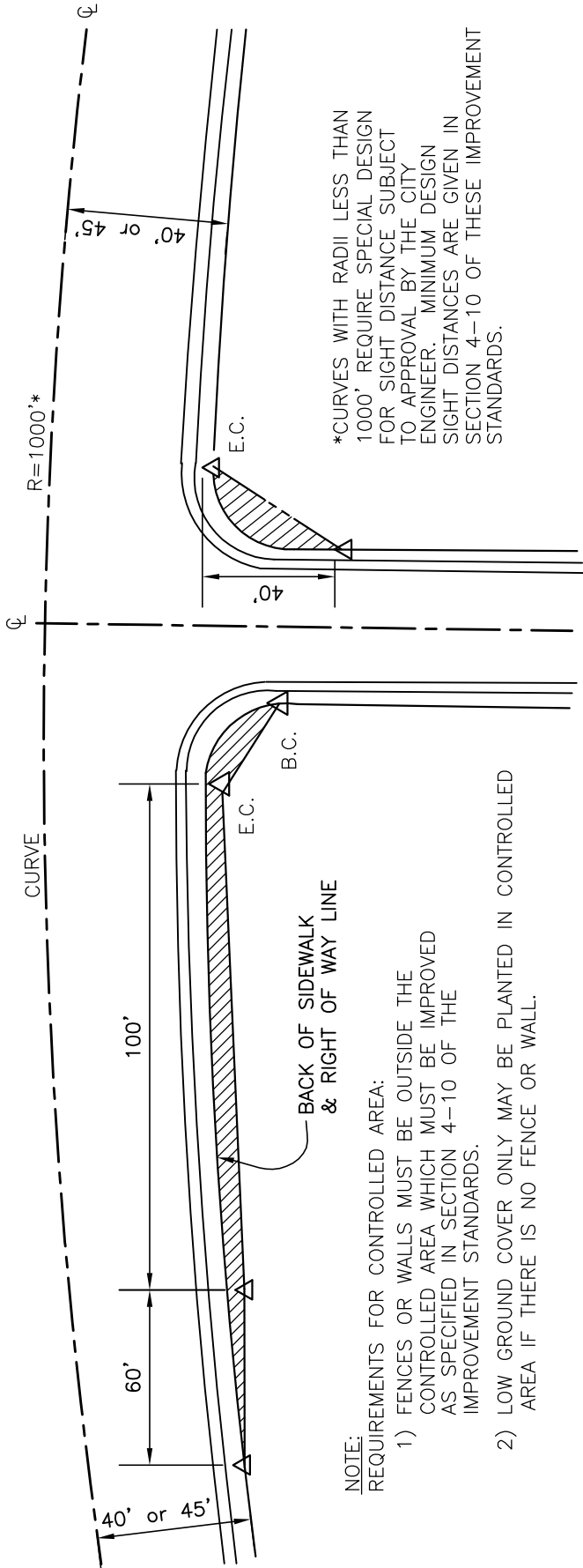

NOTE:  
REQUIREMENTS FOR CONTROLLED AREA:

- 1) FENCES OR WALLS MUST BE OUTSIDE THE CONTROLLED AREA WHICH MUST BE IMPROVED AS SPECIFIED IN SECTION 4-10 OF THE IMPROVEMENT STANDARDS.
- 2) LOW GROUND COVER ONLY MAY BE PLANTED IN CONTROLLED AREA IF THERE IS NO FENCE OR WALL.

\*CURVES WITH RADII LESS THAN 1000' REQUIRE SPECIAL DESIGN FOR SIGHT DISTANCE SUBJECT TO APPROVAL BY THE CITY ENGINEER. MINIMUM DESIGN SIGHT DISTANCES ARE GIVEN IN SECTION 4-10 OF THESE IMPROVEMENT STANDARDS.

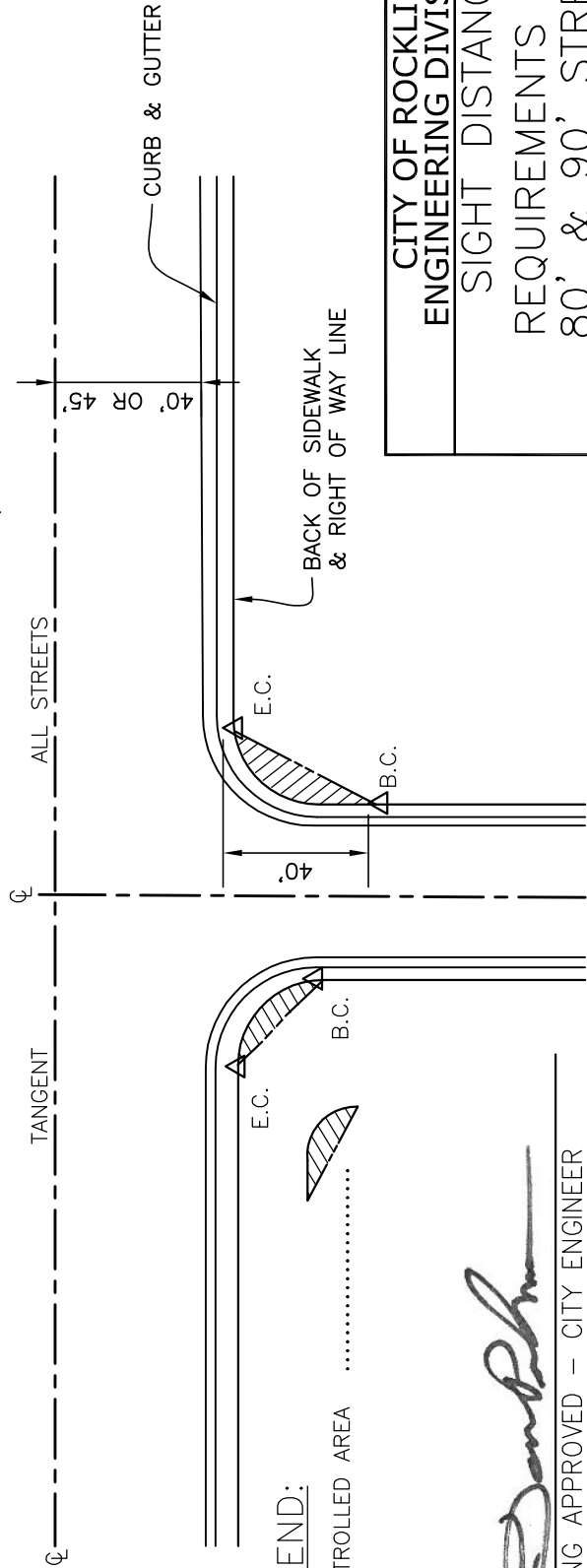

LEGEND:

CONTROLLED AREA .....

*[Signature]*  
DRAWING APPROVED - CITY ENGINEER

*[Signature]*

DRAWING APPROVED - DIRECTOR OF PUBLIC SERVICES

CITY OF ROCKLIN ENGINEERING DIVISION		DWG #
SIGHT DISTANCE REQUIREMENTS FOR 80' & 90' STREETS		3-12
SCALE: NONE	DATE: JULY 2015	
DRAWN BY: J. PINKHAM		

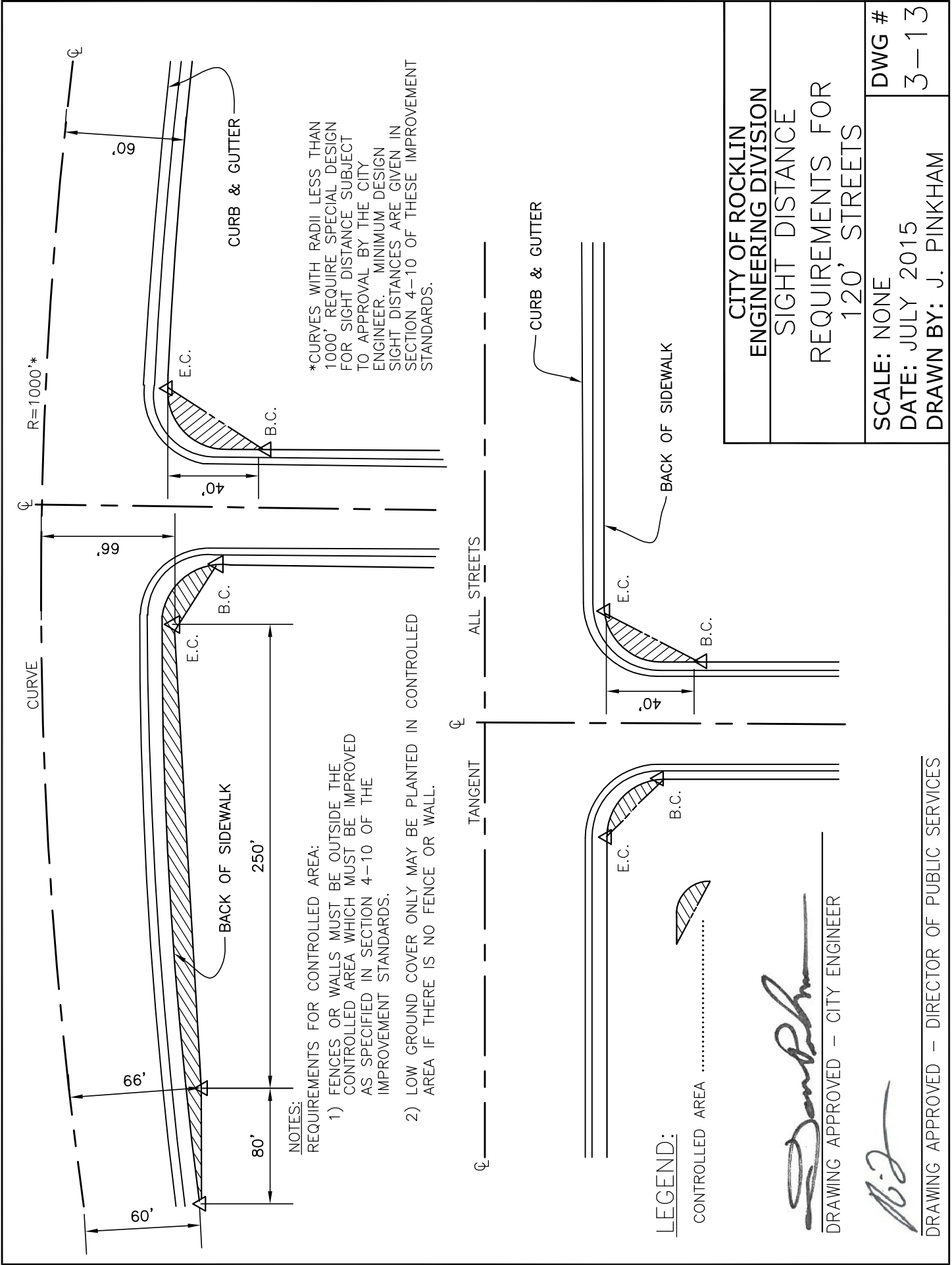

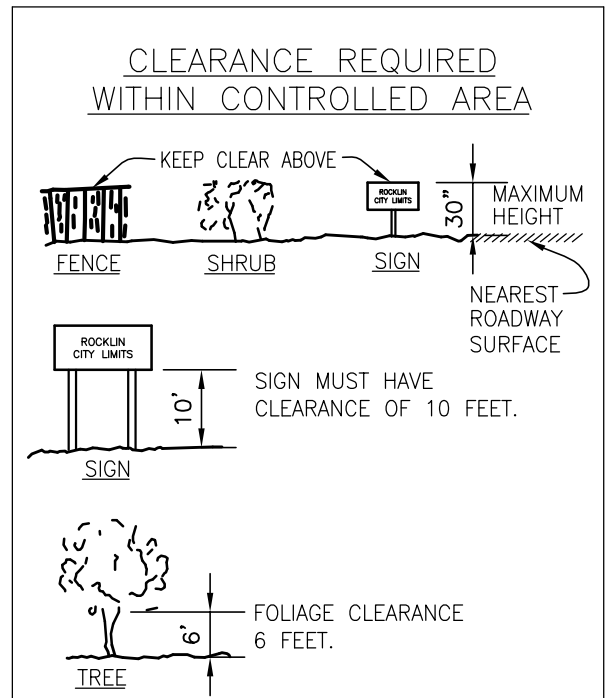
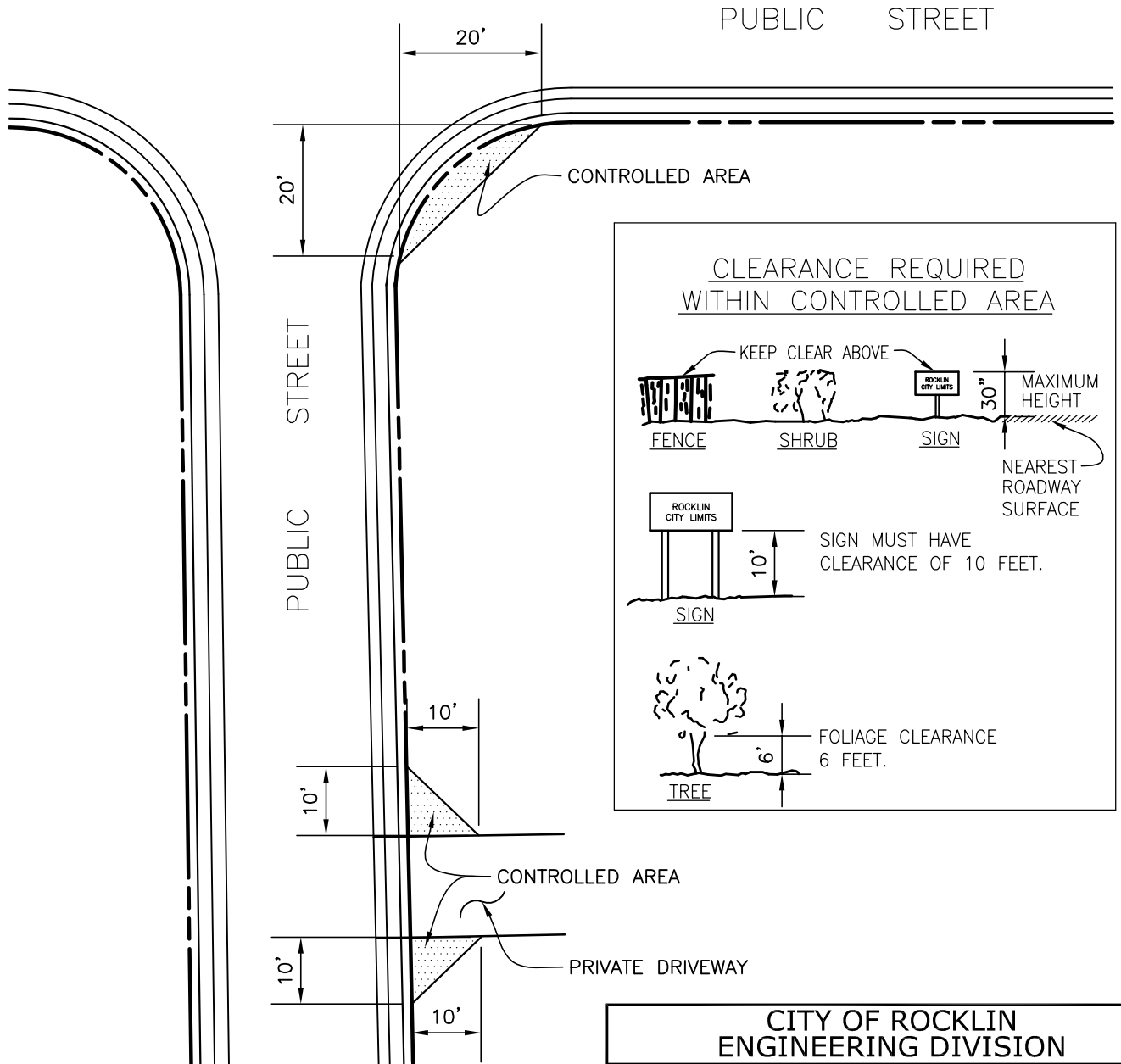
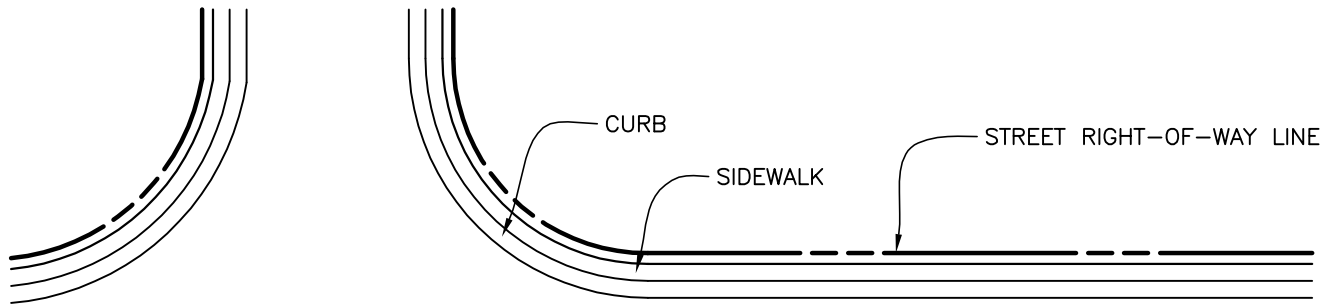

*[Signature]*  
DRAWING APPROVED - CITY ENGINEER

*[Signature]*  
DRAWING APPROVED - DIRECTOR OF PUBLIC SERVICES

CITY OF ROCKLIN  
ENGINEERING DIVISION

VISIBILITY REQUIREMENTS

SCALE: NONE  
DATE: JULY 2015  
DRAWN BY: J. PINKHAM

DWG #  
3-14

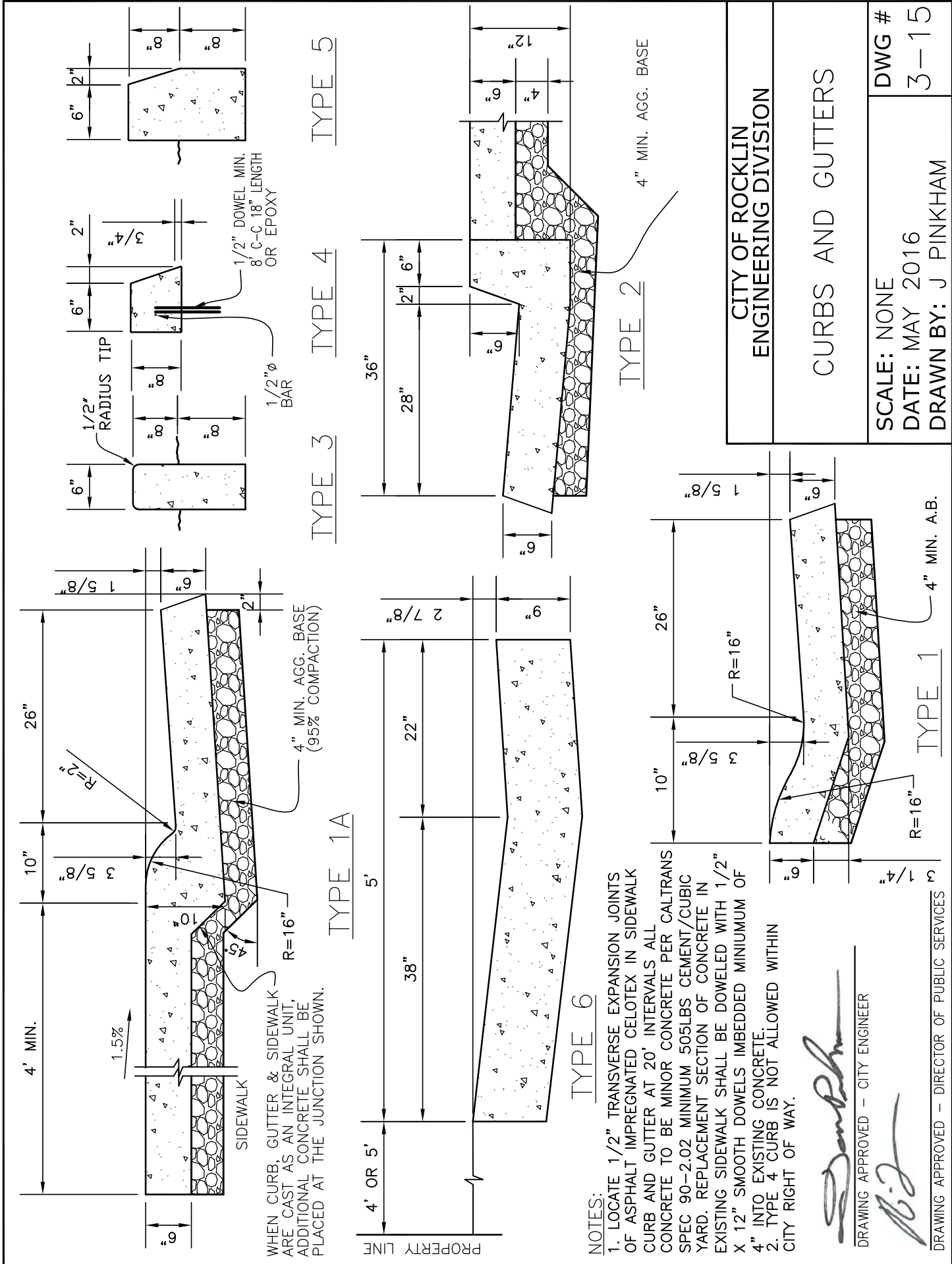

CITY OF ROCKLIN  
 ENGINEERING DIVISION

CURBS AND GUTTERS

SCALE: NONE  
 DATE: MAY 2016  
 DRAWN BY: J PINKHAM

DWG #  
 3-15

**NOTES:**

1. LOCATE 1/2" TRANSVERSE EXPANSION JOINTS OF ASPHALT IMPREGNATED CELOTEX IN SIDEWALK CURB AND GUTTER AT 20' INTERVALS ALL CONCRETE TO BE MINOR CONCRETE PER CALTRANS SPEC 90-2.02 MINIMUM 505LBS CEMENT/CUBIC YARD. REPLACEMENT SECTION OF CONCRETE IN EXISTING SIDEWALK SHALL BE DOWELED WITH 1/2" X 12" SMOOTH DOWELS IMBEDDED MINIMUM OF 4" INTO EXISTING CONCRETE.
2. TYPE 4 CURB IS NOT ALLOWED WITHIN CITY RIGHT OF WAY.

*[Signature]*  
 DRAWING APPROVED - CITY ENGINEER

*[Signature]*  
 DRAWING APPROVED - DIRECTOR OF PUBLIC SERVICES

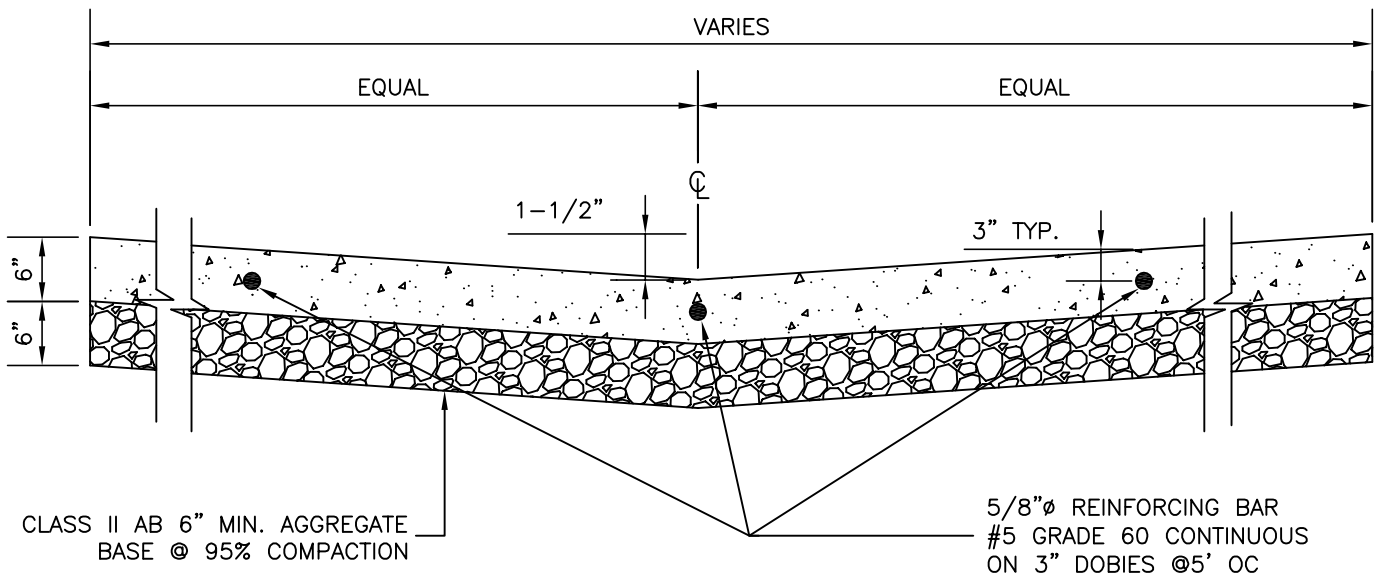

*[Signature]*  
 DRAWING APPROVED – CITY ENGINEER

*[Signature]*  
 DRAWING APPROVED – DIRECTOR OF PUBLIC SERVICES

CITY OF ROCKLIN  
 ENGINEERING DIVISION

VALLEY GUTTER

SCALE: NONE  
 DATE: MAY 2016  
 DRAWN BY: J. PINKHAM

DWG #  
 3-15A

**NOTES:**

- IF DISTANCE FROM CURB TO BACK OF SIDEWALK IS TOO SHORT TO ACCOMMODATE RAMP AND PLATFORM AS IN CASE A, THE SIDEWALK MAY BE DERESSED LONGITUDINALLY AS IN CASE B OR MAY BE WIDENED AS IN CASE D.
- IF SIDEWALK IS LESS THAN 5' WIDE, THE FULL WIDTH OF THE SIDEWALK SHALL BE DERESSED AS SHOWN IN CASE B.
- WHEN RAMPS ARE LOCATED IN CENTER OF CURB RETURN, CROSSWALK CONFIGURATION MUST BE SIMILAR TO THAT SHOWN ON THE PLAN TO ACCOMMODATE WHEELCHAIRS.
- IF PLANTING AREA WIDTH IS EQUAL TO OR GREATER THAN RAMP LENGTH (L), RAMP SIDE SLOPE (X) DISTANCE = 3' (SEE CASE C).
- FOR CASE C, THE LONGITUDINAL PORTION OF THE SIDEWALK MAY NEED TO BE DERESSED AS SHOWN IN CASE B.
- IF LOCATED ON A CURVE, THE SIDES OF THE RAMP NEED NOT BE PARALLEL, BUT THE MINIMUM WIDTH OF THE RAMP SHALL BE 4'.
- THE BOTTOM OF THE RAMP SHALL HAVE A 1/2" UP AT 45°.
- SIDEWALK AND RAMP THICKNESS, "T", SHALL BE 6".
- THE RAMP SHALL HAVE A 12" WIDE BORDER WITH 1/4" GROOVES APPROXIMATELY 3/4" ON CENTER. SEE GROOVING DETAIL. THE SURFACE OF THE RAMP SHALL HAVE A TRANSVERSE BROOMED SURFACE TEXTURE ROUGHER THAN THE SURROUNDING SIDEWALK EXCEPT WHEN LOCATED IN THE CENTER OF THE CURB RETURN.
- IF FULL WIDTH RAMP SLOPE IS LESS THAN 1% EQUAL TO 15 HIGHER THAN DIRECTOR OF PUBLIC SERVICES SHALL CONSIDER THE LATEST EDITION OF THE INTERNATIONAL BUILDING CODE SECTION.
- RAMP SIDE SLOPE VARIES UNIFORMLY FROM A MAXIMUM OF UP TO 12.5% AT CURB TO CONFORM WITH LONGITUDINAL SIDEWALK SLOPE ADJACENT TO TOP OF THE RAMP, EXCEPT IN CASES B AND C.
- UTILITY PULL BOXES, MANHOLES, VAULTS AND ALL OTHER UTILITY FACILITIES WITHIN THE BOUNDARIES OF THE CURB RAMP WILL BE RELOCATED BY OTHERS PRIOR TO, OR IN CONJUNCTION WITH, CURB RAMP CONSTRUCTION.

# USE CURRENT CALTRANS DETAIL

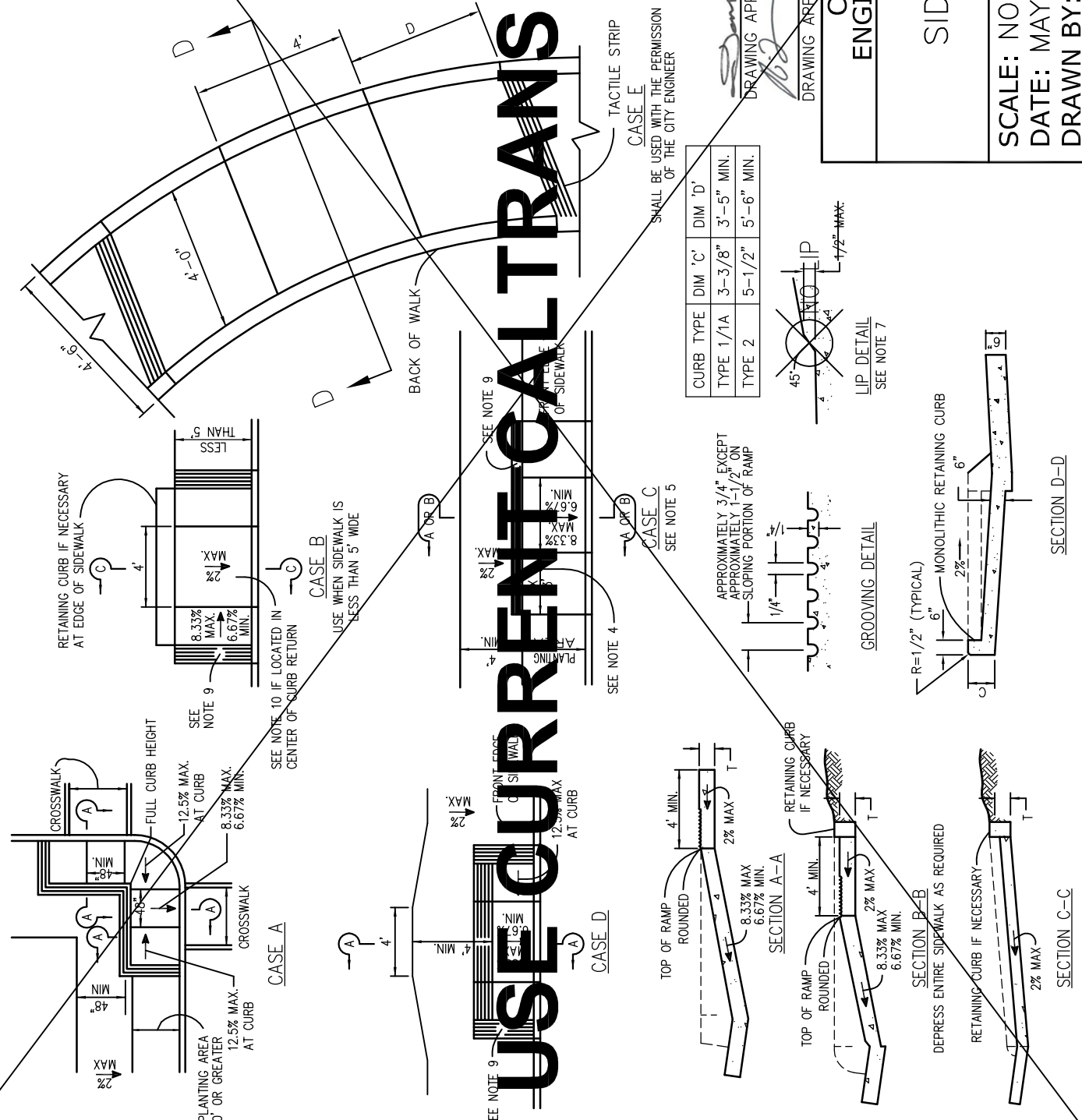

*J. Pinkham*  
 DRAWING APPROVED - CITY ENGINEER

DRAWING APPROVED - DIRECTOR OF PUBLIC SERVICES

**CITY OF ROCKLIN  
 ENGINEERING DIVISION**

**SIDEWALK RAMPS**

SCALE: NONE  
 DATE: MAY 2016  
 DRAWN BY: J. PINKHAM

DWG #  
 3-16

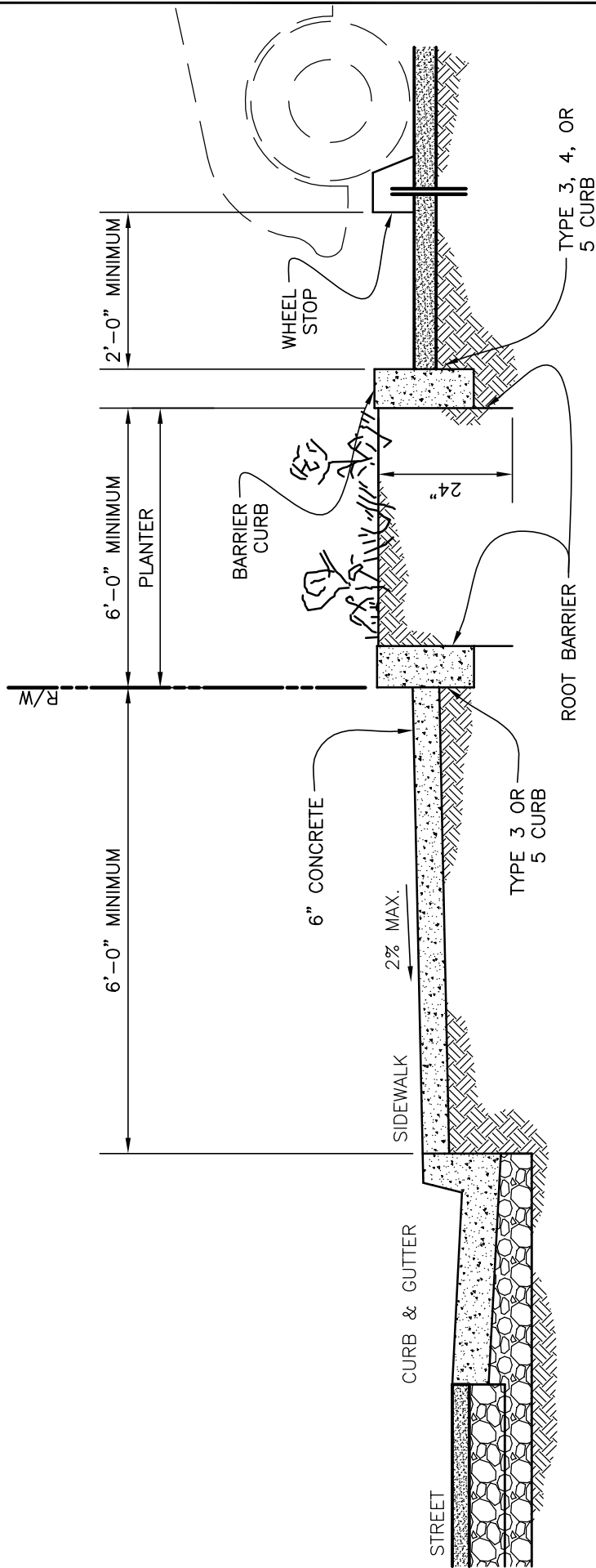

MINOR ARTERIAL, PRIMARY ARTERIAL, INDUSTRIAL  
AND COMMERCIAL DEVELOPMENT

NOTES:

1. WHEEL STOPS ARE OPTIONAL IF REQUIRED PLANTER WIDTH IS INCREASED 2'-6" OR MORE.
2. BACK OF SIDEWALK PLANTER CURBS ONLY IF LOW GROUND COVER IS PLANTED TO BACK OF SIDEWALK, AND CONTINUOUS BARRIER CURB IS PLACED AT LOCATION SHOWN.

CITY OF ROCKLIN ENGINEERING DIVISION	
PLANTER AND BARRIER CURB DETAILS	
SCALE: NONE	DWG # 3-17
DATE: AUGUST 2015	
DRAWN BY: J. PINKHAM	

*[Signature]*  
DRAWING APPROVED - CITY ENGINEER

*[Signature]*  
DRAWING APPROVED - DIRECTOR OF PUBLIC SERVICES

NOTE: DRIVEWAY TO BE USED ONLY WHERE THERE IS EXISTING VERTICAL CURB.

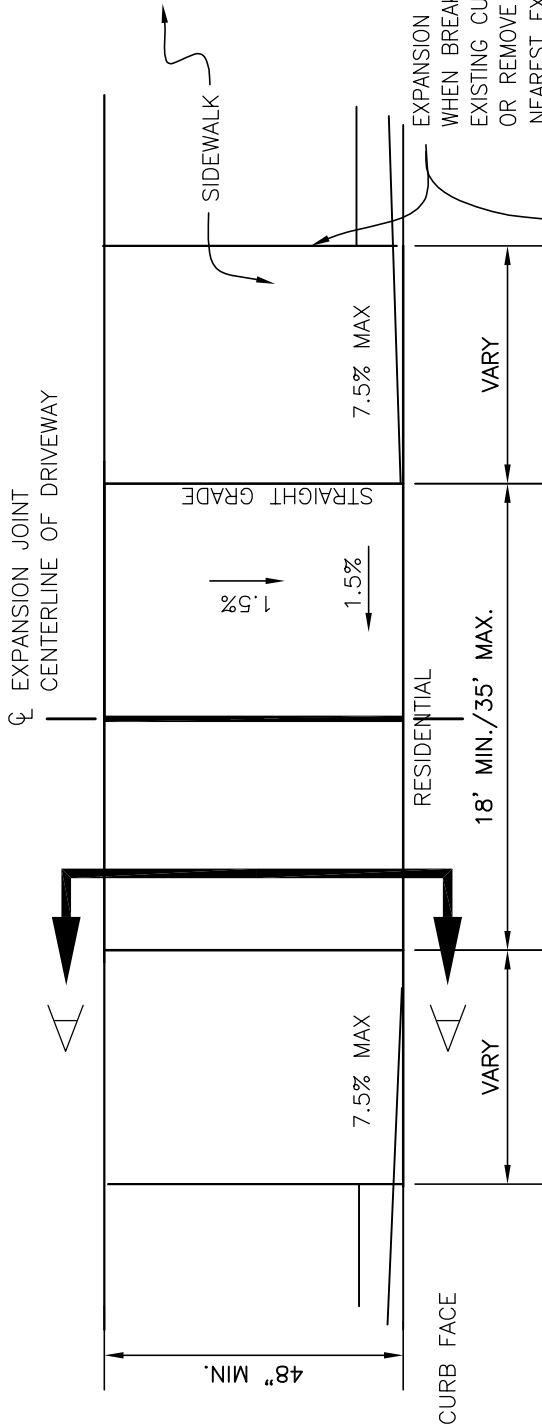

PLAN VIEW

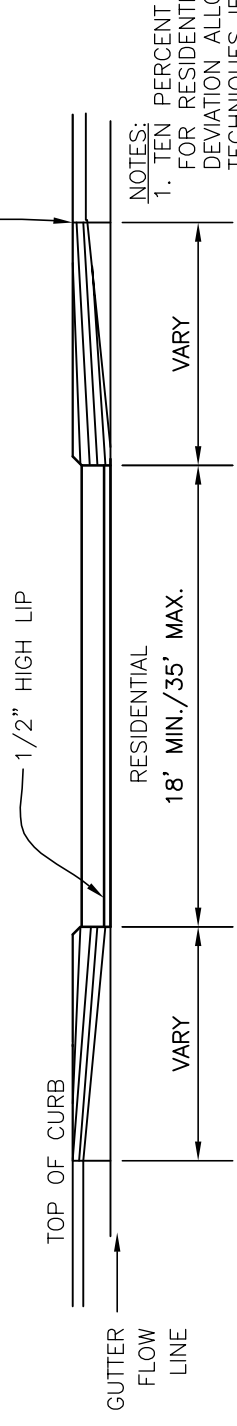

ELEVATION

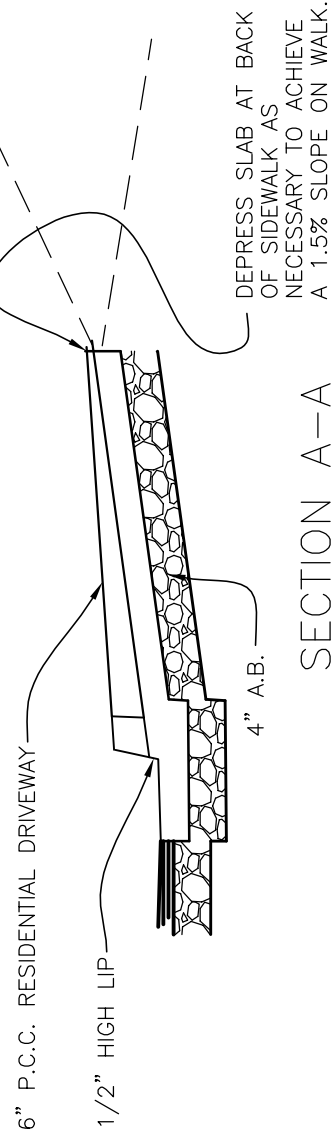

SECTION A-A

NOTES:  
 1. TEN PERCENT (10%) MAXIMUM SLOPE FOR RESIDENTIAL USES. FIVE PERCENT (5%) DEVIATION ALLOWED WITH SPECIAL CONSTRUCTION TECHNIQUES IF APPROVED BY THE CITY ENGINEER.  
 2. MAXIMUM RISE, AND THE RUN, SHALL BE MEASURED FOR THE WORST CONDITION BETWEEN THE BACK OF THE SIDEWALK AND THE FINISHED FLOOR, AT THE GARAGE OR CARPORT ENTRANCE.

CITY OF ROCKLIN  
 ENGINEERING DIVISION  
 RESIDENTIAL  
 STANDARD  
 DRIVEWAY

SCALE: NONE  
 DATE: AUGUST 2015  
 DRAWN BY: J. PINKHAM  
 DWG # 3-18

DRAWING APPROVED - CITY ENGINEER *[Signature]*  
 DRAWING APPROVED - DIRECTOR OF PUBLIC SERVICES *[Signature]*



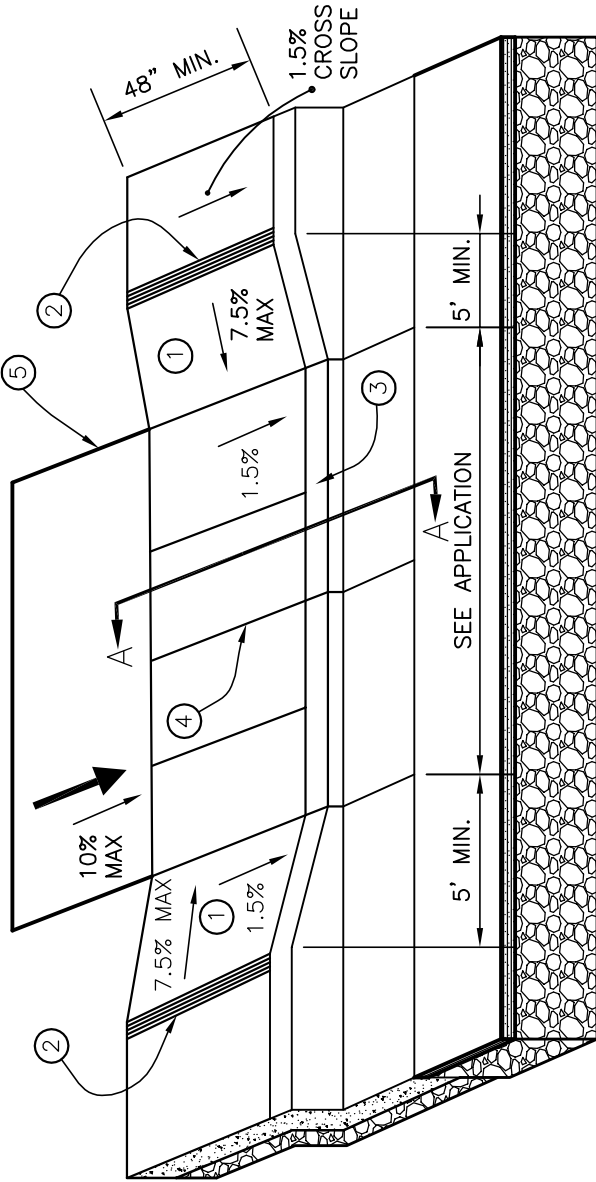

**LEGEND**

1. SLOPE OF RAMP SHALL BE A MINIMUM OF 6.67% AND A MAXIMUM OF 7.5%.
2. TACTILE STRIP. REFER TO LATEST CALTRANS STANDARD. WHEN BREAKING INTO EXISTING CURB, SAW CUT TO NEAREST EXISTING VERTICAL JOINT AND REPLACE.
3. 1/2" HIGH LIP, MAXIMUM.
4. DEEP SCORE JOINT NOT TO EXCEED 10' BETWEEN JOINTS
5. DRIVE AISLE
6. NO EXPANSION FELT IN DRIVEWAY. EXPANSION FELT AT BOTTOM OF RAMPS

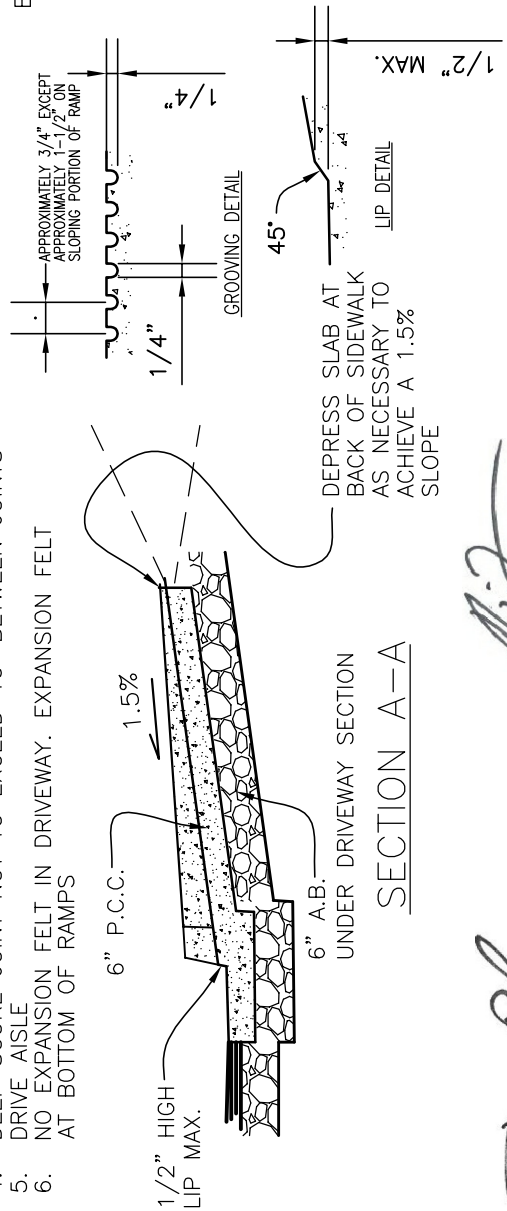

APPLICATION	MIN WIDTH	MAX WIDTH
LOTS WITH SIX (6) OR LESS SPACES SERVING RESIDENTIAL USES, EXISTING STRUCTURES CONVERTED TO OFFICE USE, AND NEWLY CONSTRUCTED OFFICES (IF ACCESS IS LESS THAN 150' FROM STREET).	15'	20'
LOTS WITH SIX (6) OR LESS SPACES SERVING COMMERCIAL AND INDUSTRIAL USES AND WHERE ANY BUILDING TO BE SERVED IS MORE THAN 150' FROM THE STREET R/W.	25'	35'
LOTS WITH MORE THAN SIX (6) SPACES, BUT LESS THAN 20 SPACES AND WITH SEPARATE ENTRANCES AND EXITS (ONE WAY DRIVEWAYS)	25'	35'
LOTS WITH MORE THAN SIX (6) SPACES, BUT LESS THAN 20 SPACES AND WITH ONLY ONE POINT OF ENTRANCE AND EXIT (TWO WAY DRIVEWAYS) AND LOTS WITH 20 OR MORE SPACES SERVING OFFICE & RESIDENTIAL USES.	25'	35'
LOTS WITH 20 OR MORE SPACES SERVING COMMERCIAL AND INDUSTRIAL USES.	25'	45'
LOTS WHERE ANY TYPE OF USE REQUIRES FIRE TRUCK ACCESS BY DRIVEWAY.	25'	45'

- NOTES:**
- A. FIVE PERCENT (5%) MAXIMUM SLOPE FOR COMMERCIAL AND INDUSTRIAL USES. FIVE PERCENT (5%) DEVIATION ALLOWED WITH SPECIAL CONSTRUCTION TECHNIQUES IF APPROVED BY THE CITY ENGINEER.
  - B. MAXIMUM RISE, AND THE RUN, SHALL BE MEASURED FOR THE WORST CONDITION BETWEEN THE BACK OF THE SIDEWALK AND THE FINISHED FLOOR, AT THE GARAGE OR CARPORT ENTRANCE.

**CITY OF ROCKLIN  
ENGINEERING DIVISION**

**COMMERCIAL AND  
INDUSTRIAL STANDARD  
DRIVEWAY**

<b>SCALE: NONE</b>	<b>DWG #</b>
<b>DATE: DECEMBER 2015</b>	<b>3-19</b>
<b>DRAWN BY: J. PINKHAM</b>	

DRAWING APPROVED - DIRECTOR OF PUBLIC SERVICES

DRAWING APPROVED - CITY ENGINEER

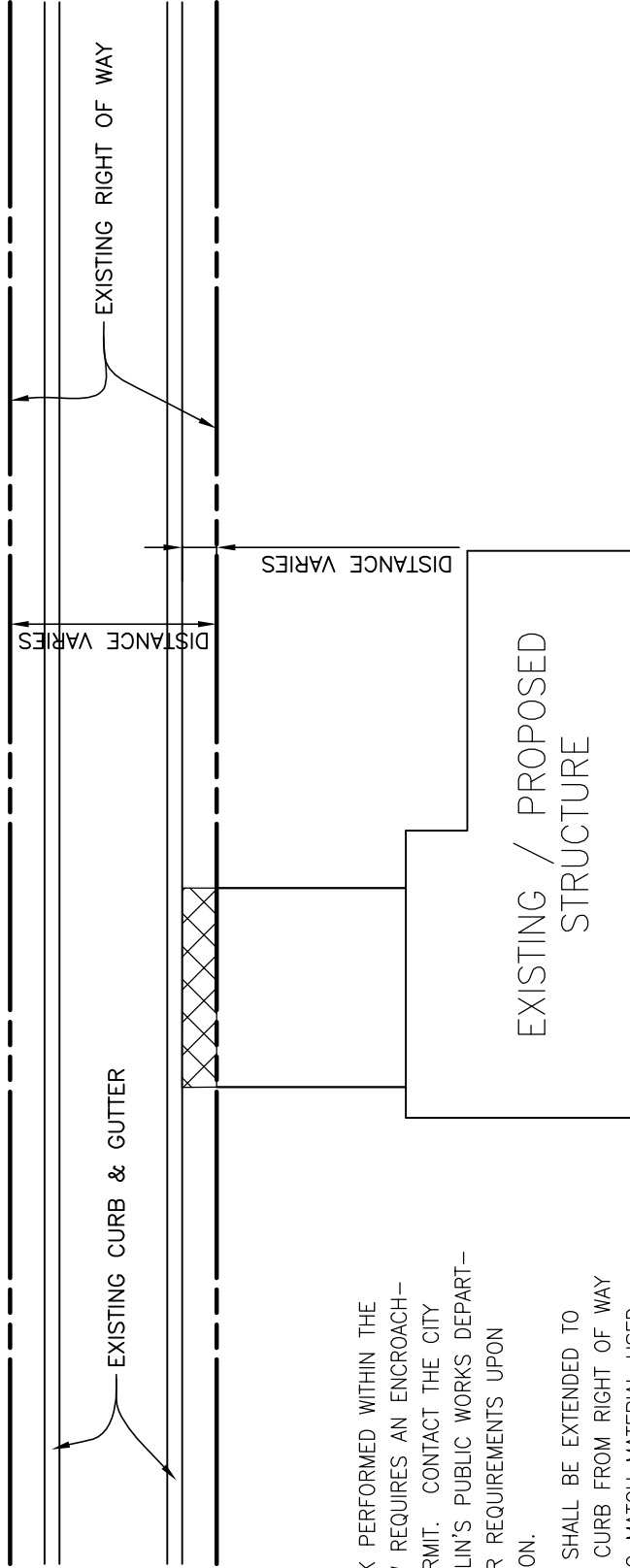

NOTES:

- 1) ANY WORK PERFORMED WITHIN THE CITY R/W REQUIRES AN ENCROACHMENT PERMIT. CONTACT THE CITY OF ROCKLIN'S PUBLIC WORKS DEPARTMENT FOR REQUIREMENTS UPON APPLICATION.
- 2) DRIVEWAY SHALL BE EXTENDED TO BACK OF CURB FROM RIGHT OF WAY AND IS TO MATCH MATERIAL USED FOR DRIVEWAY I.E.: CONCRETE, AC, ETC.

CITY OF ROCKLIN ENGINEERING DIVISION	
DRIVEWAY APPROACH DETAIL FOR AREAS WITH CURB & GUTTER; NO SIDEWALKS	
SCALE: NONE	DWG #
DATE: AUGUST 2015	3-20
DRAWN BY: J. PINKHAM	

  
 DRAWING APPROVED - CITY ENGINEER  
  
 DRAWING APPROVED - DIRECTOR OF PUBLIC SERVICES

**IF NO SIDEWALK**

**IF SIDEWALK**

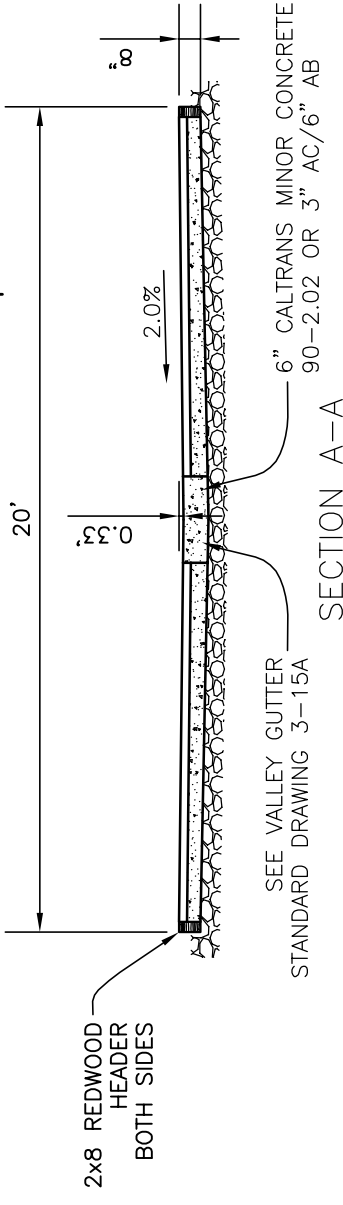
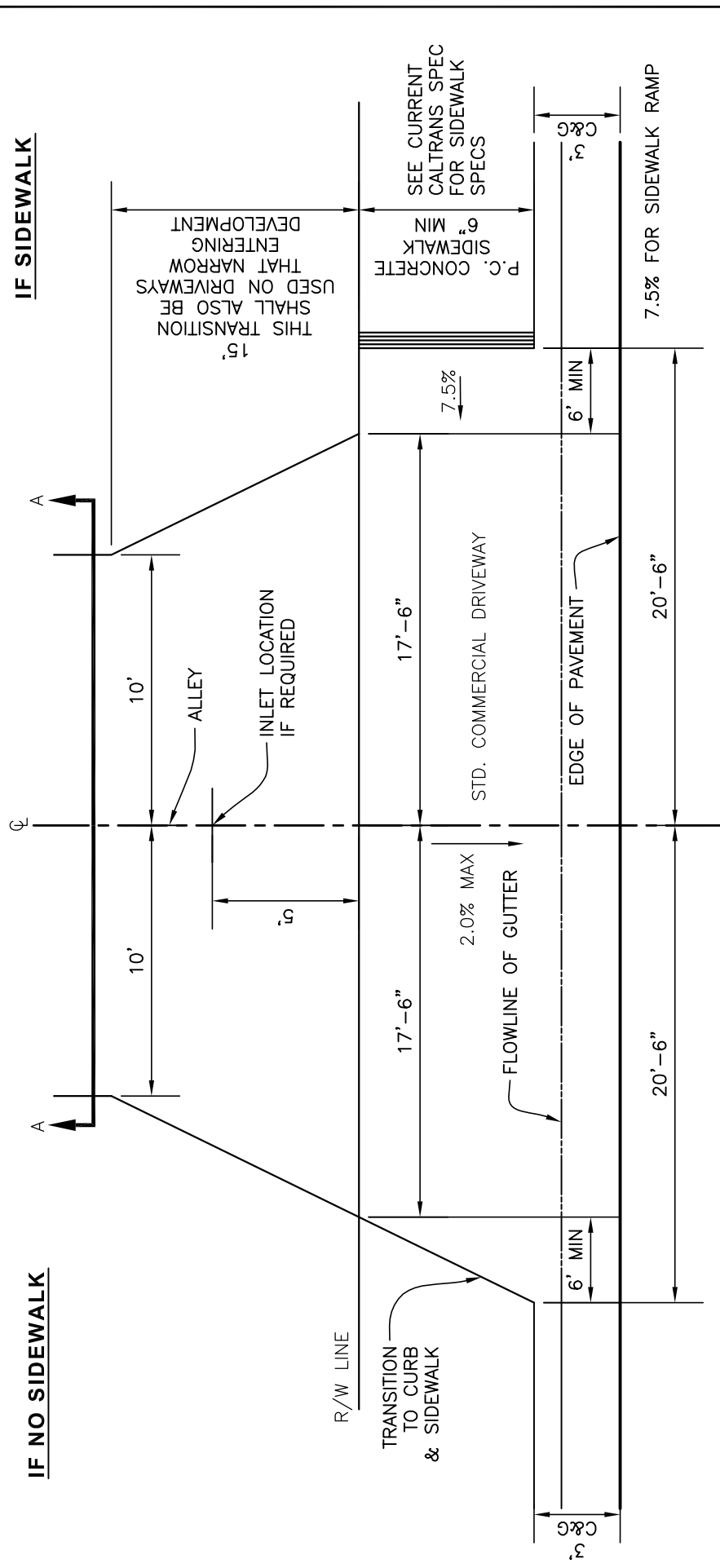

**CITY OF ROCKLIN  
ENGINEERING DIVISION  
ALLEY DETAILS  
AND DRIVEWAY  
TRANSITIONS**

SCALE: NONE  
DATE: MAY 2016  
DRAWN BY: J. PINKHAM

DRAWING APPROVED - DIRECTOR OF PUBLIC SERVICES

DRAWING APPROVED - CITY ENGINEER

DWG #  
3-21

FRONTAGE  
(EACH STREET)

MAXIMUM NUMBER OF  
DRIVEWAYS

UNDER 200' ..... ONE STD DRIVEWAY  
OVER 200' ..... TWO STD DRIVEWAYS OR MEET  
APPROVAL OF THE DIRECTOR

**NOTES:**

1. 25' TO 35' WIDTH DRIVEWAYS MAY BE APPROVED ON 60' AND 66' STREETS.  
35' TO 45' WIDTH DRIVEWAYS MAY BE APPROVED ON 80', 90', AND 120' STREETS.
2. 20' MINIMUM ALLOWABLE DISTANCE BETWEEN DRIVEWAYS FOR LESS THAN  
200' FRONTAGE AND 40' MINIMUM ALLOWABLE DISTANCE BETWEEN DRIVEWAYS  
FOR FRONTAGES OF 200' AND OVER.

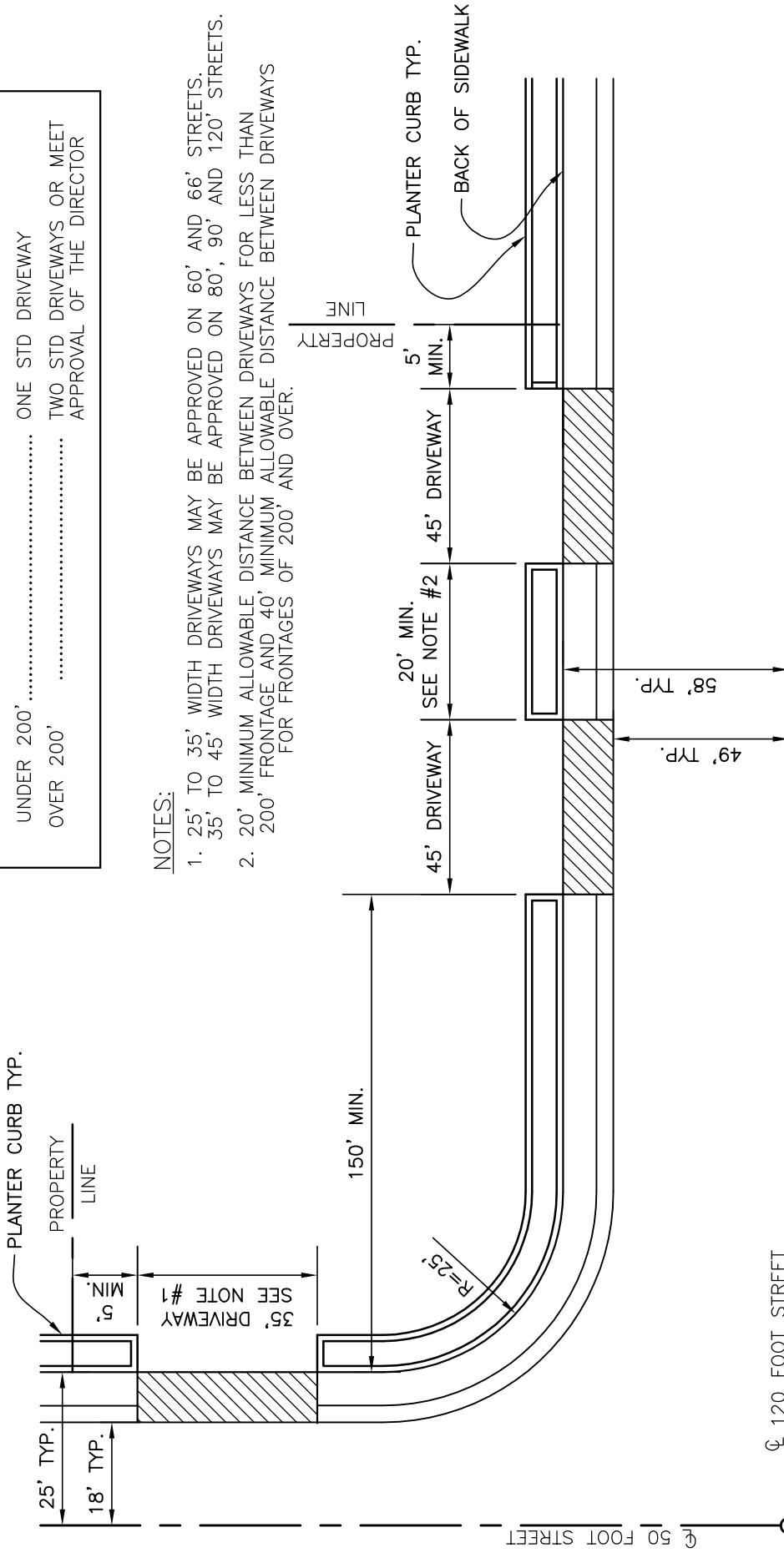

CITY OF ROCKLIN ENGINEERING DIVISION	
COMMERCIAL FRONTAGE AND DRIVEWAY REGULATIONS	
SCALE: NONE	DWG #
DATE: AUGUST 2015	3-22
DRAWN BY: J. PINKHAM	

*[Signature]*  
DRAWING APPROVED - CITY ENGINEER

*[Signature]*  
DRAWING APPROVED - DIRECTOR OF PUBLIC SERVICES

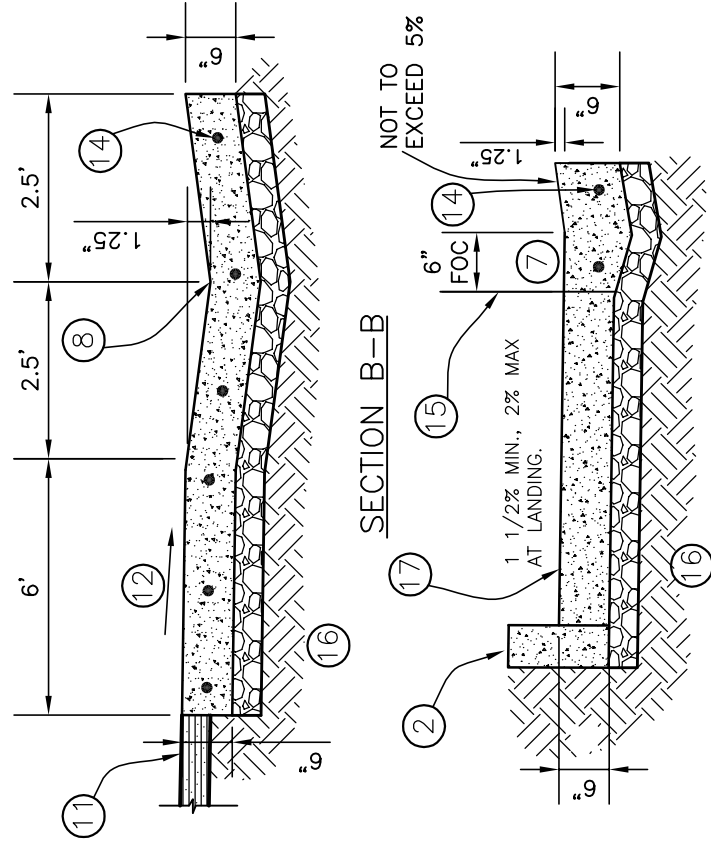
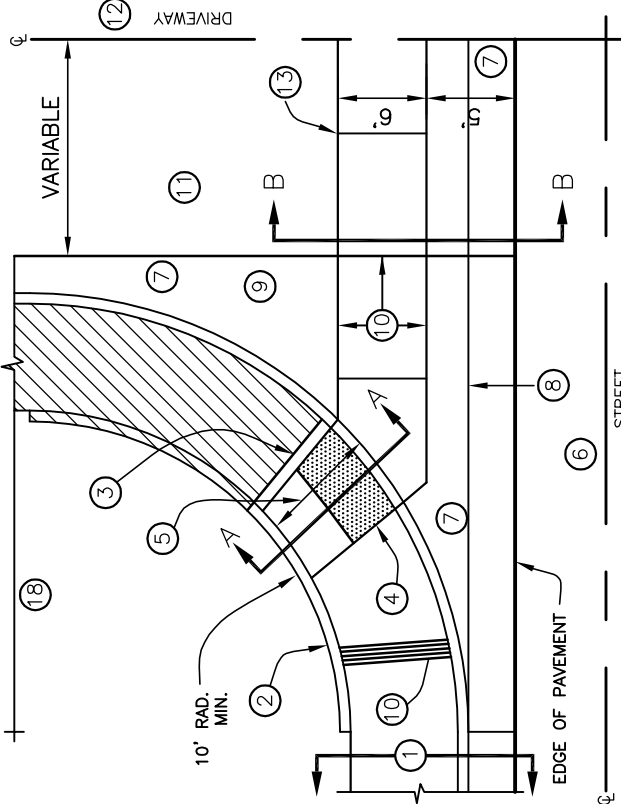

1. "TYPE 2" (3-15) CURB AND GUTTER WITH SIDEWALK OUTSIDE DRIVEWAY AREA
2. RETAINING CURB AT BACK OF WALK, HEIGHT VARIES
3. PLACE RAMP IF SIDEWALK EXTENDS ON SITE (CROSSHATCHED AREA); EXTEND RETAINING CURB IF NO ON-SITE SIDEWALK. (AT #3 ARROW)
4. TYPE 1 RAMP WITH TRUNCATED DOME PANEL; NUMBER 4 LINE COINCIDES WITH BACK OF V GUTTER (TYP). NO LIP.
5. LANDING DEPTH IS 6 FEET DEEP. TRANSITION TO ADJACENT WALK WIDTH FROM LANDING TO CURB RETURN.
6. STREET PAVING
7. DRIVEWAY 8 INCHES THICK PER SECTION B-B, SIDEWALK 6 INCHES PER SECTION A-A
8. GUTTER FLOW LINE
9. PLACE GUTTER, WALKS, AND CURBS MONOLITHICALLY. POUR MAY BE SEPARATED WITH COLD JOINT AT NUMBER 9 LINE.
10. SEE GROOVING DETAIL 3-19
11. PRIVATE PAVING PER APPROVED PLANS
12. MAXIMUM GRADE OF 2%, MINIMUM 1%
13. SCORE MARKS, TYPICAL 1.5" DEEP
14. NO. 4 REBAR, 18 INCHES O.C. EACH WAY, 3 INCH DOBIES WITH WIRE TIES AT 3 FOOT INTERVALS, EACH WAY
15. EXTENDED CURB FACE
16. IN DRIVEWAY, CLASS II, 3/4 INCH AGGREGATE BASE OR NATIVE SUBGRADE; EITHER PROCESSED TO 95% RELATIVE COMPACTION. UNDER SIDEWALK, NATIVE SOIL, MINIMUM 6 INCH, PROCESSED TO 95% RELATIVE COMPACTION. AGGREGATE BASE THICKNESS SHALL BE AT THE CONTRACTOR'S DISCRETION.
17. ALL SIDEWALK 1% MINIMUM, 2% MAXIMUM CROSS GRADE TOWARD STREET
18. STANDARD RADIUS IS 20-FEET. WHERE DELIVERY TRUCKS WILL ACCESS DRIVEWAYS, RADIUS WILL BE INCREASED TO 30-FEET

  
 DRAWING APPROVED - CITY ENGINEER  
  
 DRAWING APPROVED - DIRECTOR OF PUBLIC SERVICES

<b>CITY OF ROCKLIN</b> <b>ENGINEERING DIVISION</b> <b>SPECIAL COMMERCIAL</b> <b>FRONTAGE ENTRANCE</b> <b>TYPE A-7</b>	<b>SCALE: NONE</b> <b>DATE: DECEMBER 2015</b> <b>DRAWN BY: J. PINKHAM</b>	<b>DWG #</b> <b>3-23</b>
---	---	-----------------------------

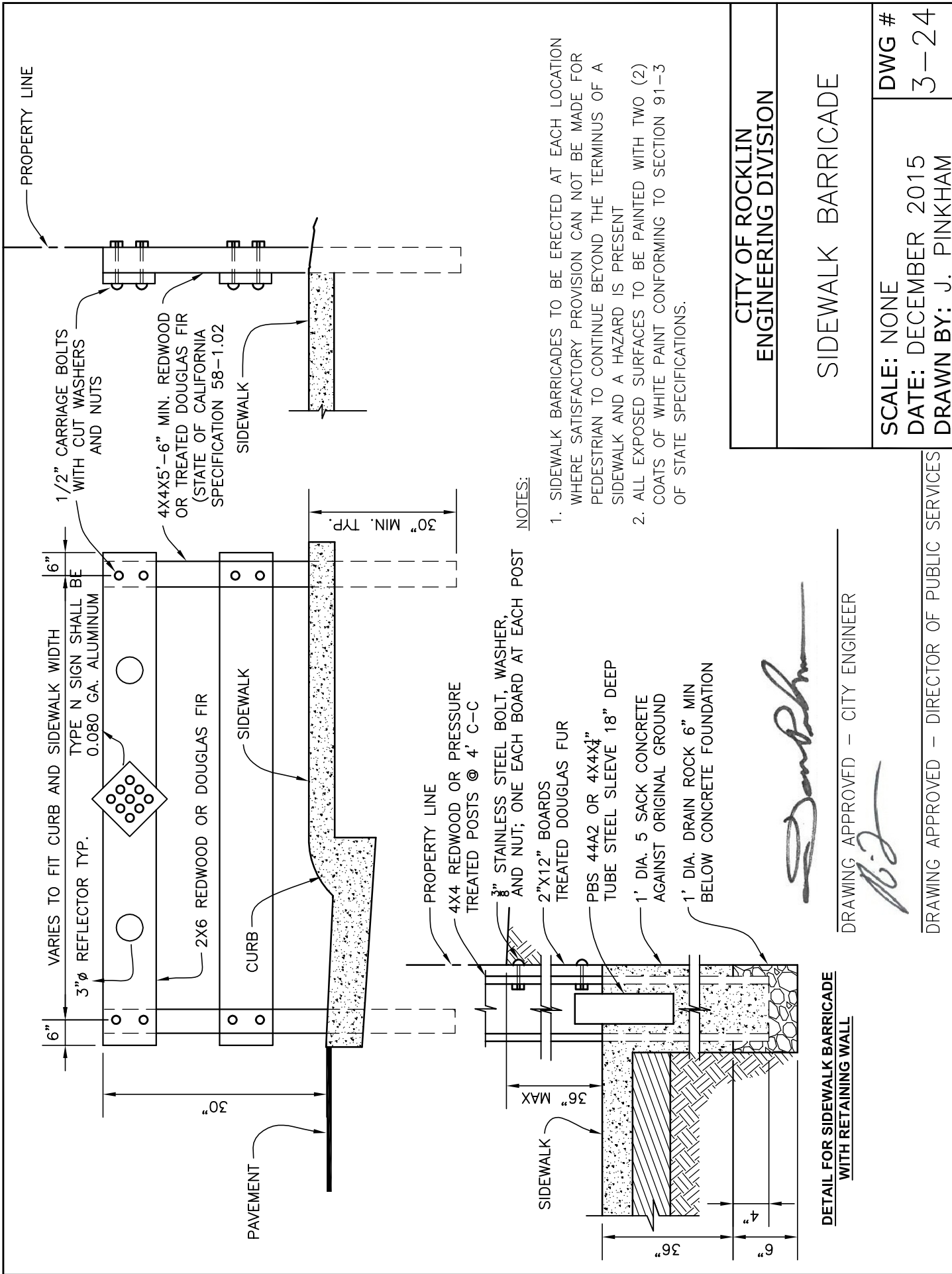

**NOTES:**

1. SIDEWALK BARRICADES TO BE ERECTED AT EACH LOCATION WHERE SATISFACTORY PROVISION CAN NOT BE MADE FOR PEDESTRIAN TO CONTINUE BEYOND THE TERMINUS OF A SIDEWALK AND A HAZARD IS PRESENT
2. ALL EXPOSED SURFACES TO BE PAINTED WITH TWO (2) COATS OF WHITE PAINT CONFORMING TO SECTION 91-3 OF STATE SPECIFICATIONS.

<b>CITY OF ROCKLIN ENGINEERING DIVISION</b>	
<b>SIDEWALK BARRICADE</b>	
<b>SCALE:</b> NONE	<b>DWG #</b> 3-24
<b>DATE:</b> DECEMBER 2015	
<b>DRAWN BY:</b> J. PINKHAM	

**DETAIL FOR SIDEWALK BARRICADE  
WITH RETAINING WALL**

DRAWING APPROVED - CITY ENGINEER

DRAWING APPROVED - DIRECTOR OF PUBLIC SERVICES

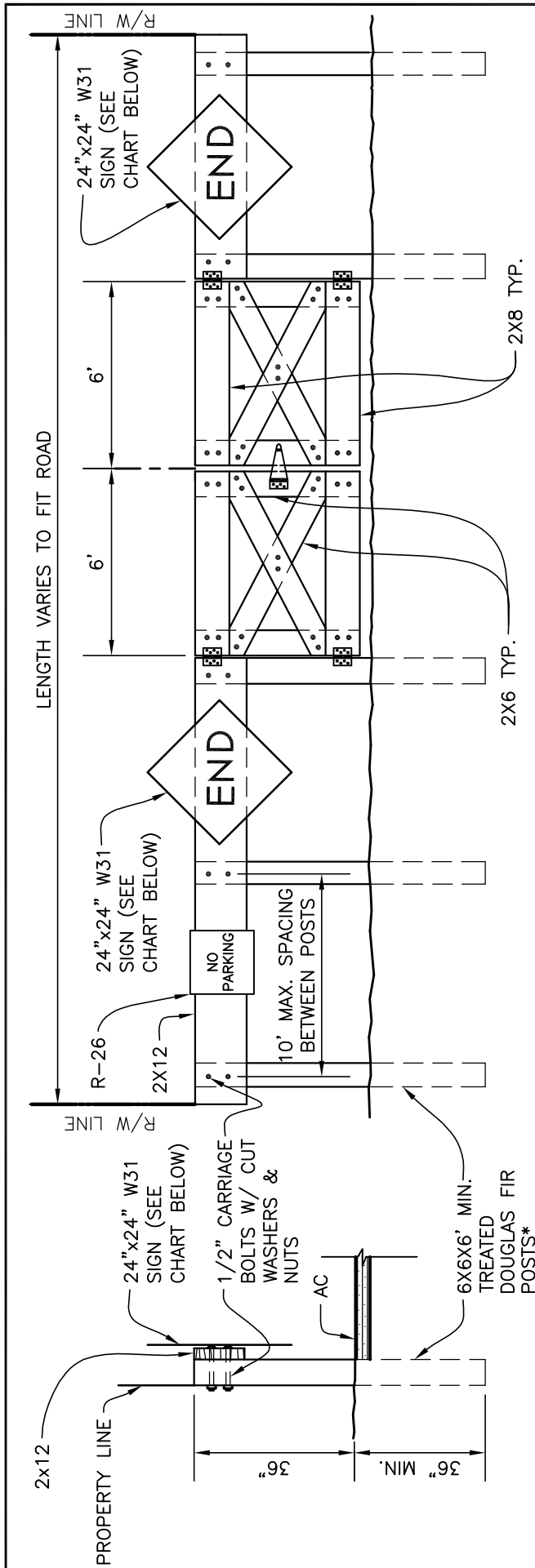

NUMBER AND SIZE OF SIGNS

R/W WIDTH	W31		TYPE N		C2		SIGN	
	SIZE	NO.	SIZE	NO.	SIZE	NO.	NO.	NO.
42' & 46'	24"	1	18"	1	36" X 24"	1		
50' & 66'	24"	1	18"	1	48" X 30"	1		
80' & 90'	24"	2	18"	2	48" X 30"	1		
110'	24"	3	18"	3	48" X 30"	1		

\* STATE OF CALIFORNIA SPECIFICATION 56-2.02B

NOTES:

1. WHERE PERMISSION HAS BEEN GRANTED TO CLOSE EXISTING PUBLIC STREET, A C2 "ROAD CLOSED" SIGN WILL BE REQUIRED ON THE CENTERLINE OF THE ROAD IN ADDITION TO THE W31 "END" SIGNS.
2. 24" x 24" W31 SIGNS AND 18" x 18" RED TYPE N MARKERS. BLOCK OUT AS NECESSARY FOR TYPE N MARKER TOP MOUNTING BOLT (BOTTOM MOUNTING BOLT NORMALLY THROUGH BARRIER RAIL.)
3. ALL SIGNS TO BE H.I.P. OR BETTER.
4. ALL EXPOSED SURFACES SHALL BE PAINTED WITH WHITE PAINT CONFORMING TO SECTION 91-3.02.
5. POST AT CENTER OR NEAREST TO CENTER ON RIGHT HAND SIDE TO BE EXTENDED TO PROVIDE MOUNTING FOR SIGNS.

CITY OF ROCKLIN  
ENGINEERING DIVISION  
STREET CLOSURE  
GATED TIMBER  
BARRICADE

SCALE: NONE  
DATE: DECEMBER 2015  
DRAWN BY: J. PINKHAM

DWG #  
3-25

*[Signature]*  
DRAWING APPROVED - CITY ENGINEER

*[Signature]*  
DRAWING APPROVED - DIRECTOR OF PUBLIC SERVICES

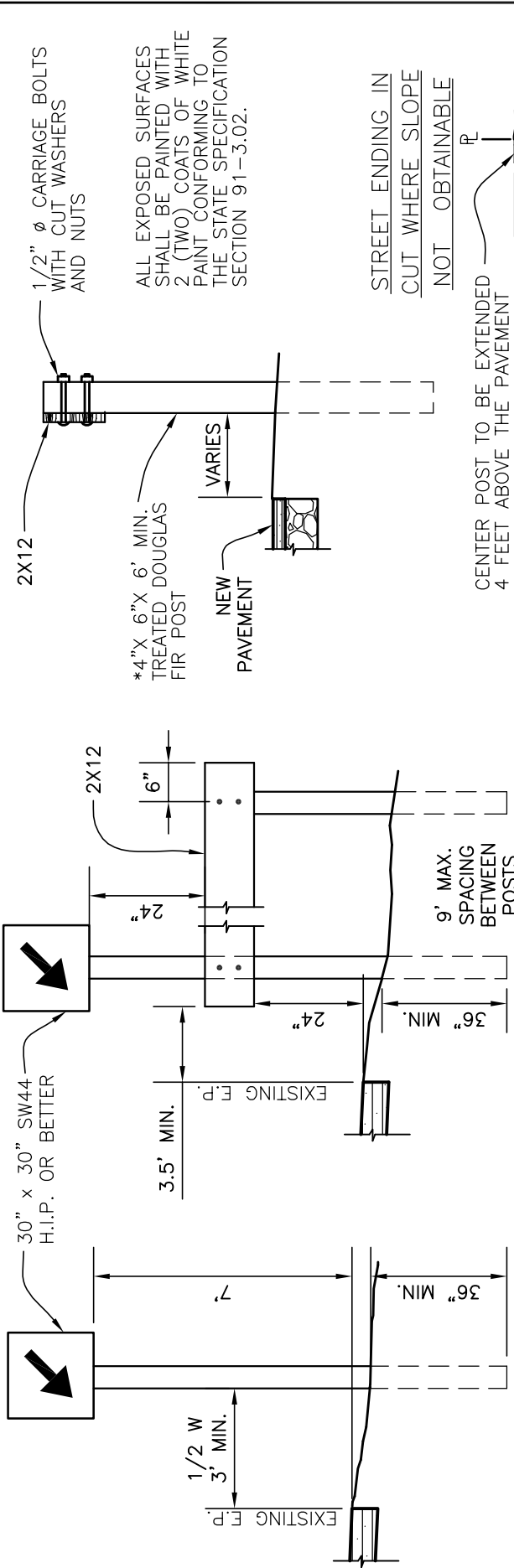

1/2"  $\phi$  CARRIAGE BOLTS WITH CUT WASHERS AND NUTS

ALL EXPOSED SURFACES SHALL BE PAINTED WITH 2 (TWO) COATS OF WHITE PAINT CONFORMING TO THE STATE SPECIFICATION SECTION 91-3.02.

STREET ENDING IN CUT WHERE SLOPE NOT OBTAINABLE

CENTER POST TO BE EXTENDED 4 FEET ABOVE THE PAVEMENT FOR A SIGN ON THE POST.

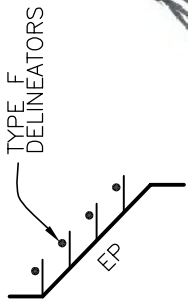
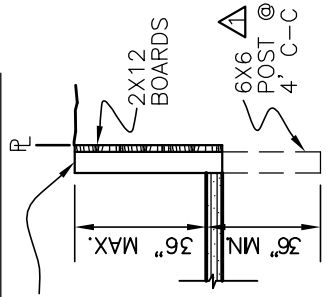

*Handwritten signature*

DRAWING APPROVED - DIRECTOR OF PUBLIC SERVICES	
CITY OF ROCKLIN ENGINEERING DIVISION	
SIGNS AND BARRICADES	
AT END OF PAVEMENT WIDENING	
SCALE: NONE	DWG # 3-26
DATE: DECEMBER 2015	
DRAWN BY: J. PINKHAM	

\* STATE OF CALIFORNIA SPECIFICATIONS

$\Delta$  POST AT SIDE NEAREST THE EDGE OF PAVEMENT TO BE OF SUFFICIENT HEIGHT TO PROVIDE FOR THE MOUNTING OF REQUIRED SIGNS.

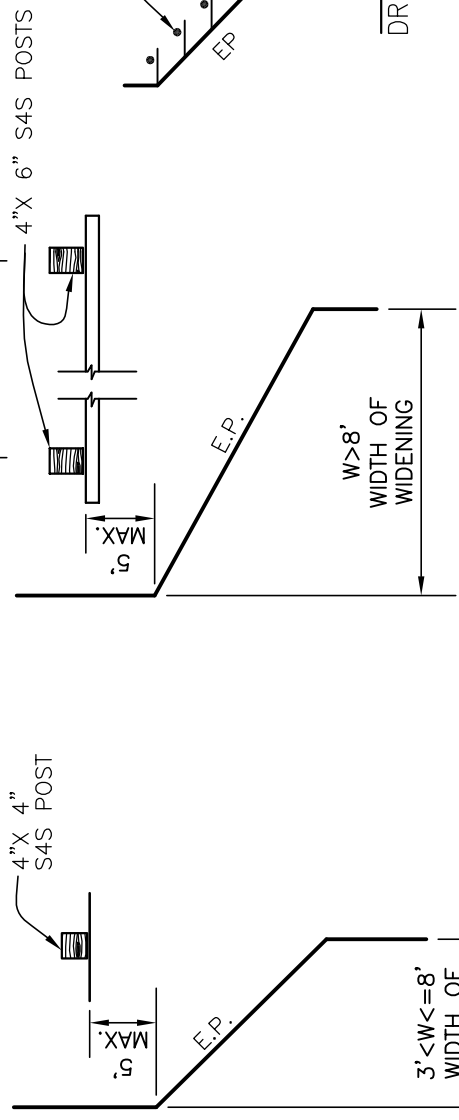

*Handwritten signature*

DRAWING APPROVED - CITY ENGINEER



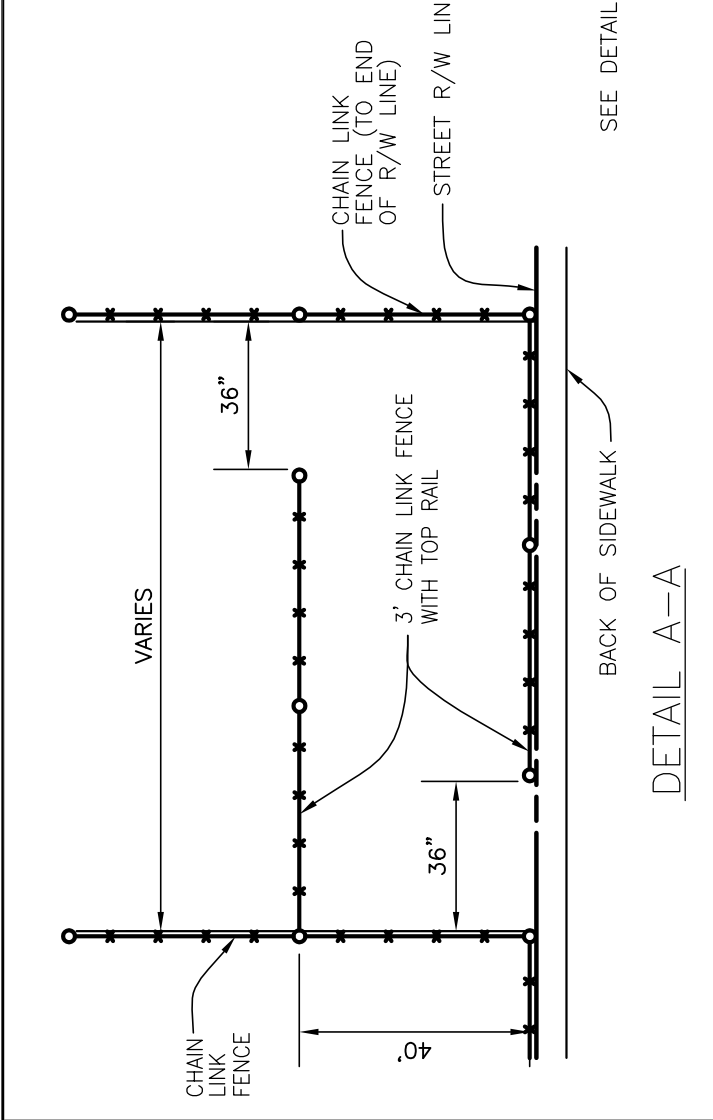
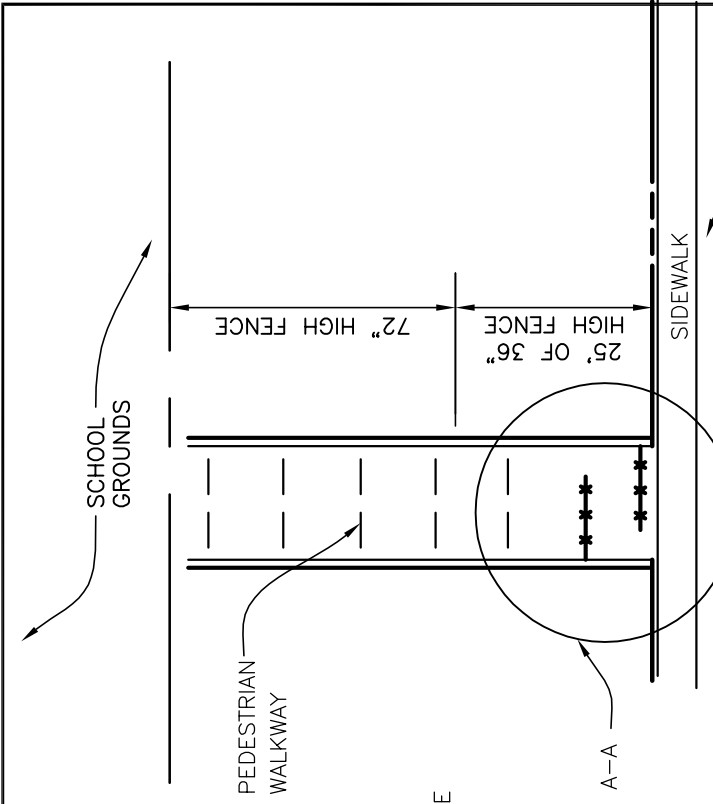

NOTE:  
 CHAIN LINK FENCING SHALL BE 3 FT. HIGH WITH A 1-1/4" DIAMETER TOP RAIL WITHIN THE BUILDING SETBACK LINE AND 6 FT. HIGH OUTSIDE OF THE BUILDING SETBACK LINE. CHAIN LINK FENCING SHALL BE IN ACCORDANCE WITH SECTION SS-83 OF THE STANDARD SPECIFICATIONS.

*[Signature]*  
 DRAWING APPROVED - CITY ENGINEER

*[Signature]*  
 DRAWING APPROVED - DIRECTOR OF PUBLIC SERVICES

CITY OF ROCKLIN ENGINEERING DIVISION		DWG #
PEDESTRIAN LANE WITH BIKE BARRIER		3-27
SCALE: NONE	DATE: AUGUST 2015	
DRAWN BY: J. PINKHAM		

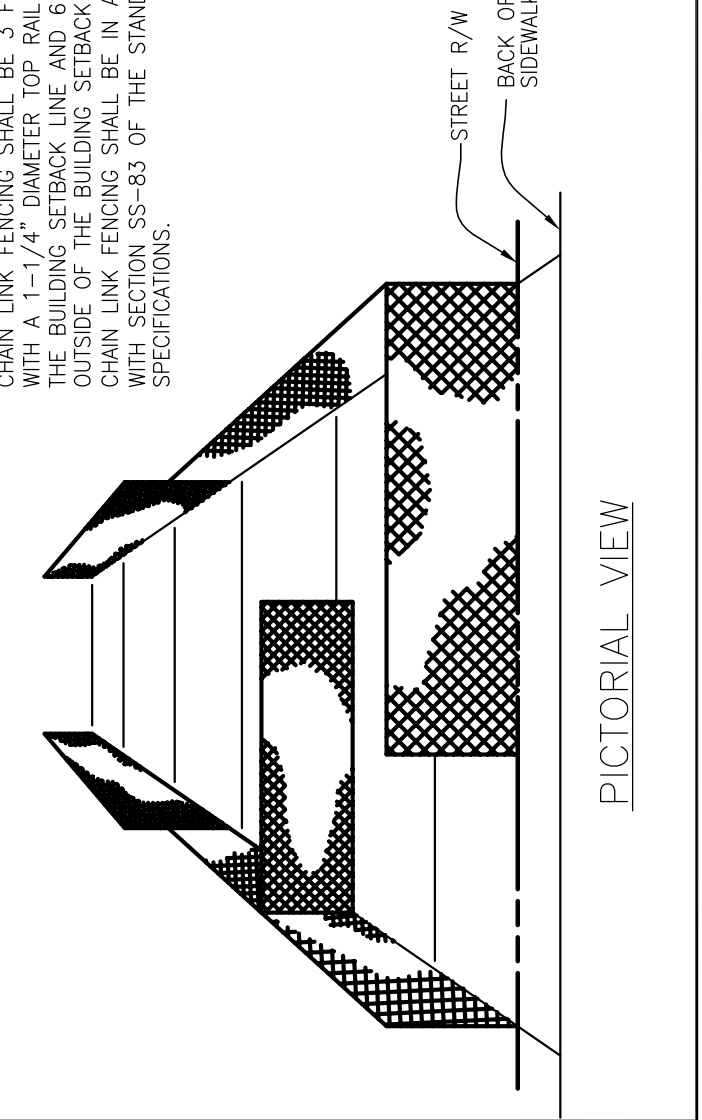

PICTORIAL VIEW

(ARTERIAL/COLLECTOR)

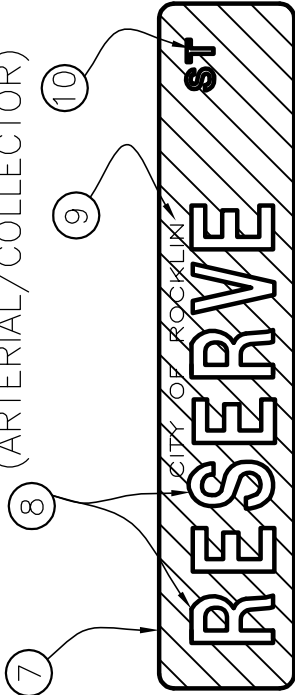

(RESIDENTIAL)

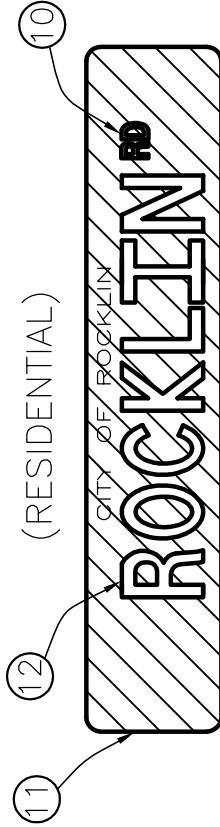

**NOTES:**

1. STREET NAME SIGNS, SEE DRAWING.
2. SIGN POST SHALL BE A 2 INCH BY 2 INCH 14 GAUGE BREAKAWAY BLACK POWDER COATED METAL SQUARE POST WITH HOLES PER THE CONSTRUCTION STANDARDS.
3. BACK OF CITY SIDEWALK.
4. 18 INCHES BACK OF SIDEWALK, 24 INCHES BACK OF CURB IF NO SIDEWALK.
5. HOLE SHALL BE EXCAVATED TO A REQUIRED MINIMUM DEPTH OF 28" DEEP AND 10" IN DIAMETER. CONCRETE BACKFILL SHALL BE PER SPECIFICATIONS.
6. A 30" LONG ANCHOR SLEEVE SHALL BE INSTALLED AND BACKFILLED PER NOTE 5. TWO HOLES OF THE SLEEVE SHALL REMAIN ABOVE FINISH GRADE. ALL HOLES OF THE SLEEVE BELOW FINISH GRADE SHALL BE TAPED CLOSED. NO MATERIAL OTHER THAN THE SQUARE POST SHALL INTRUDE INTO THE SLEEVE. THE SQUARE POST INSIDE THE SLEEVE SHALL MOVE FREELY IN THE VERTICAL DIRECTION UPON INSTALLATION.
7. SIGN BLANK SHALL BE EIGHT INCH HIGH, 0.080 GAUGE ALUMINUM, 24, 30, OR 36 INCHES LONG. FINISH SHALL BE 3M, OR APPROVED EQUIVALENT, HIGH INTENSITY GRADE REFLECTORIZED BACKGROUND WITH ELECTRONIC CUTABLE GREEN FILM SHEETING. SIGN ATTACHMENT SHALL HAVE TWO 3/8 INCH ALUMINUM DRIVE RIVETS ATTACHED THROUGH EACH PLATE INTO THE POST.
8. FIRST LETTER UPPERCASED, THE FOLLOWING LOWERCASED, WHITE HIGH INTENSITY PRISMATIC REFLECTIVE SHEETING
9. "CITY OF ROCKLIN" SHALL BE IN 1 INCH LETTERS CENTERED ACROSS THE TOP OF THE BLADE.
10. ST, AVE, CT, WY, CIRCLE, DR, ETC., TWO INCH UPPER CASE SERIES C, HIGHWAY FONT TEXT FLUSH WITH TOP OF 6 INCH TEXT.
11. FOUR INCHES HIGH, SERIES C, UPPER CASE LETTERS, HIGHWAY FONT, CENTERED TOP AND SIDE OF PLATE.
12. IN THE EVENT THE STREET NAME IS TOO LONG FOR A 36 INCH LONG SIGN, THE NEXT LOWER SERIES TEXT, SERIES C OR B, CAN BE USED.

FLUSH AT TOP

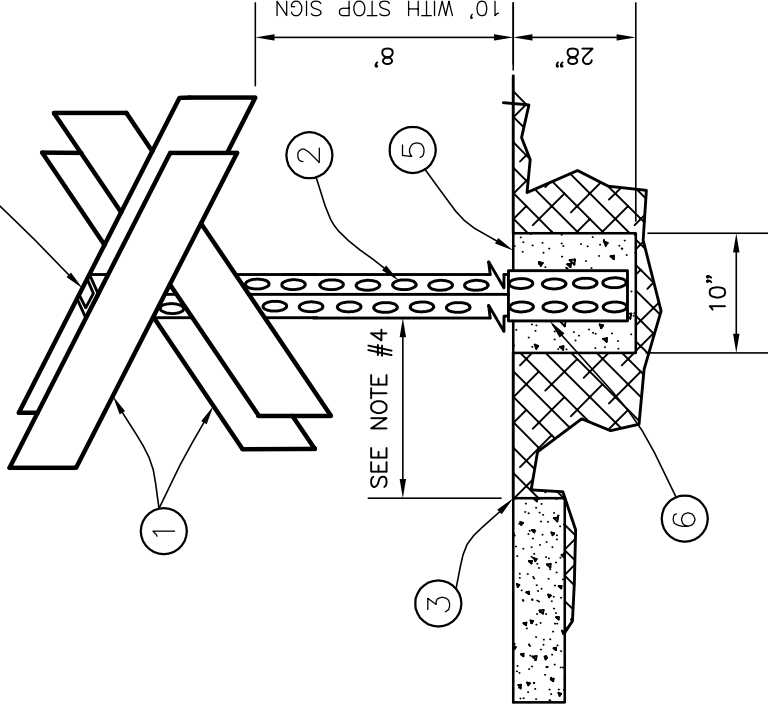

*[Signature]*  
 DRAWING APPROVED – CITY ENGINEER

*[Signature]*  
 DRAWING APPROVED – DIRECTOR OF PUBLIC SERVICES

**CITY OF ROCKLIN**  
**ENGINEERING DIVISION**  
 RESIDENTIAL  
 STREET  
 SIGNS

SCALE: NONE	DWG #
DATE: DECEMBER 2015	3-28
DRAWN BY: J. PINKHAM	

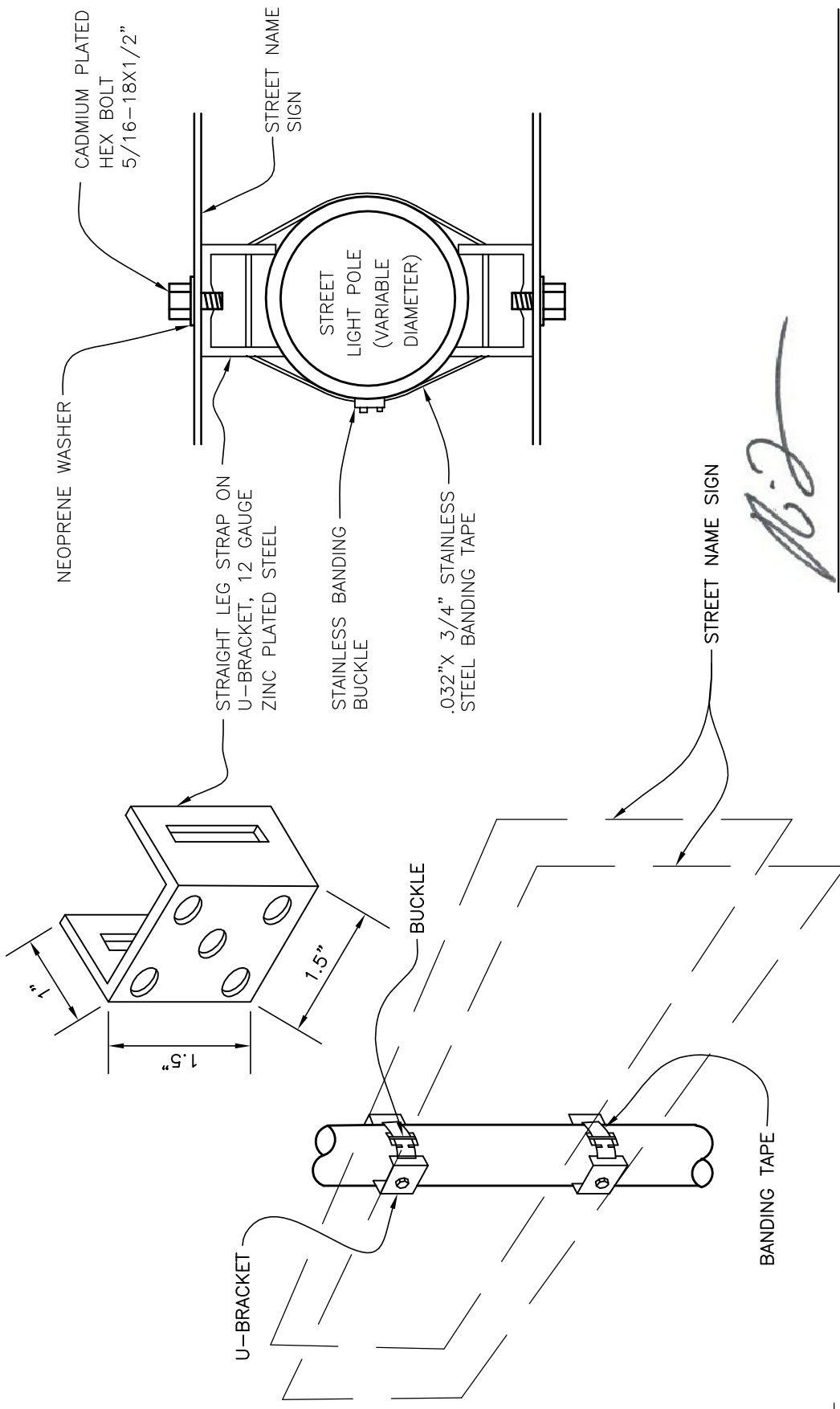

**NOTE:**

DETAIL SHOWN IS FOR TWO SIGN INSTALLATION. FOUR SIGN INSTALLATION MAY BE MADE, WHERE APPLICABLE, BY FASTENING A SECOND PAIR OF SIGNS IN THE SAME MANNER.

STANDARD CLEARANCE TO BOTTOM OF LOWEST SIGN IS 7 FEET.

SIGNS ARE NOT TO INTERFERE WITH STREET LIGHT NUMBERS.

*[Signature]*

DRAWING APPROVED - CITY ENGINEER

DRAWING APPROVED - DIRECTOR OF PUBLIC SERVICES

<b>CITY OF ROCKLIN</b>	
<b>ENGINEERING DIVISION</b>	
STREET NAME SIGN	
INSTALLATION ON	
STREET LIGHT POLE	
SCALE: NONE	DWG #
DATE: AUGUST 2015	3-29
DRAWN BY: J. PINKHAM	

*[Signature]*

NOTE:

1. WHEN STREET LIGHTS ARE AT THE INTERSECTION, THE STANDARD IS SET SO THAT THE STREET SIGN CAN BE ATTACHED TO IT.

2. STREET LIGHTS, STREET NAME SIGNS, AND STOP SIGNS ARE TO BE PLACED AT THE MID RADIUS POINT OF THE CORNER.

PLACE STREET NAME SIGN OVER STOP SIGN WHEN NO STREET LIGHT IS SET BEHIND SIDEWALK.

FIRE HYDRANT BEHIND SIDEWALK @ CURB RETURN.

STREET NAME SIGN OVER STOP SIGN OR STREET NAME SIGN ONLY SHALL BE 6" BEHIND SIDEWALK.

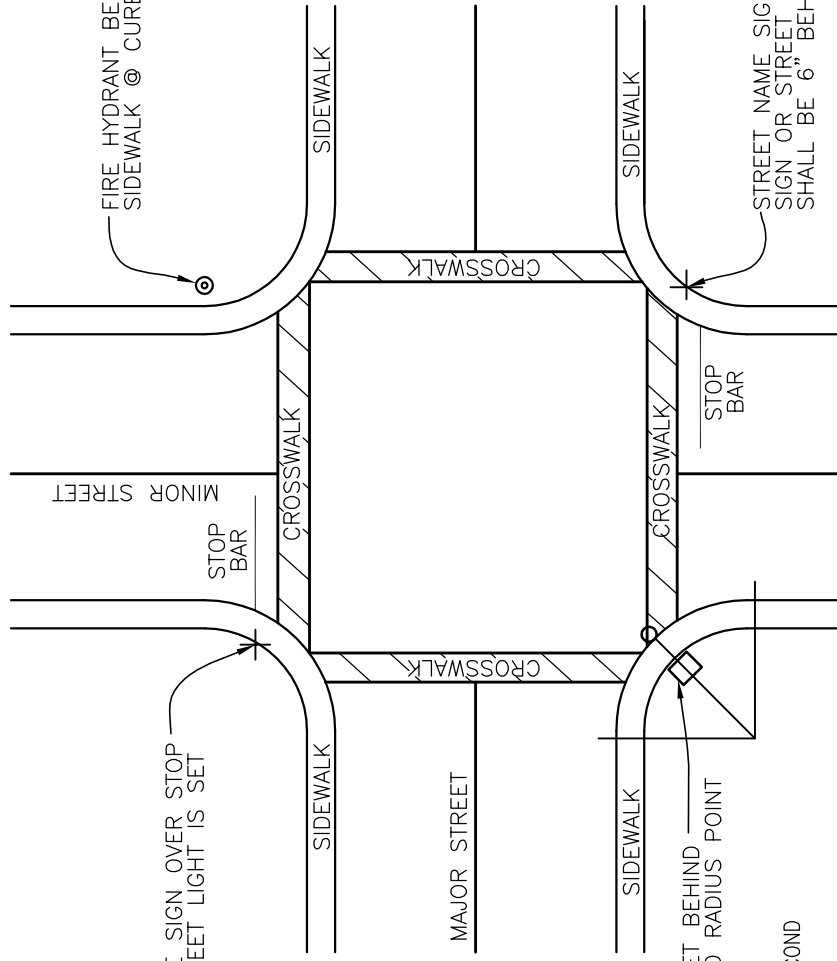

STREET LIGHT SET BEHIND SIDEWALK AT MID RADIUS POINT

LOCATION FOR SECOND SIGN ONLY.

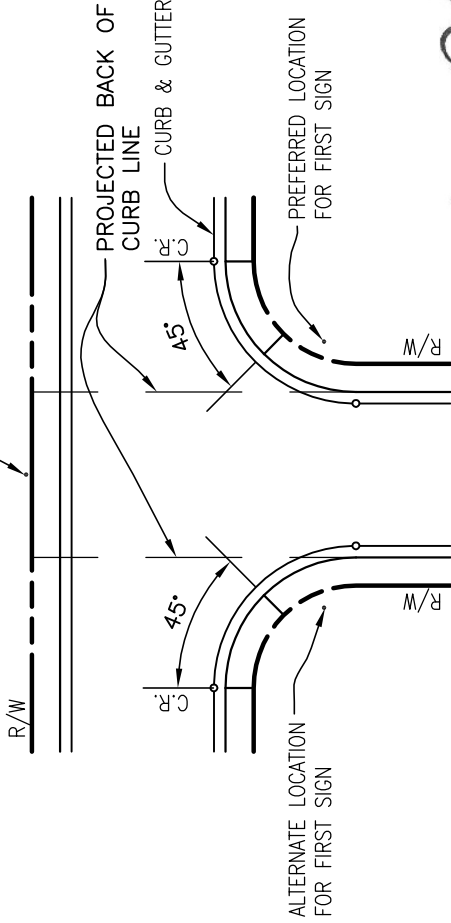

*[Handwritten signature]*

DRAWING APPROVED – DIRECTOR OF PUBLIC SERVICES

CITY OF ROCKLIN  
ENGINEERING DIVISION  
STREET LIGHT &  
STREET SIGN  
PLACEMENT DETAILS

SCALE: NONE	DWG #
DATE: AUGUST 2015	3-30
DRAWN BY: J. PINKHAM	

*[Handwritten signature]*

DRAWING APPROVED – CITY ENGINEER

LEGEND

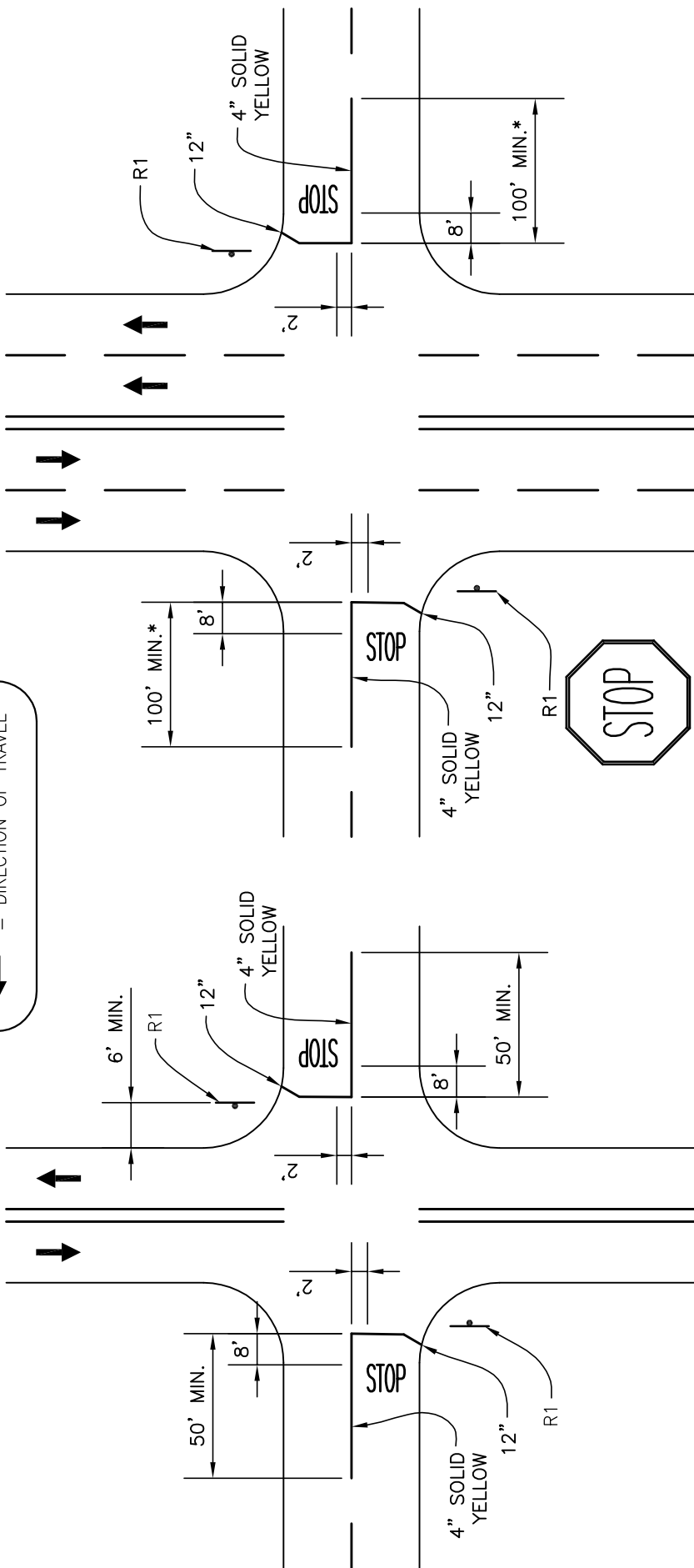

\* AS APPROVED BY CITY ENGINEER

MULTILANE

2-LANE

NOTES:

1. ALL PAVEMENT MARKINGS SHALL BE THERMOPLASTIC PER THE MOST RECENT CALTRANS SPECIFICATION.
2. THE LIMIT LINE ON WIDE SIDE ROADS OR LONG RADIUS CORNERS MAY BE BENT AT A 45°± ANGLE FOR TRAFFIC MAKING A RIGHT TURN.
3. THE LIMIT LINE SHOULD BE LOCATED TO INDICATE THE POINT WHICH TRAFFIC IS REQUIRED TO STOP (CVC 377).
4. A LIMIT LINE SHALL BE PLACED ON PAVED APPROACHES TO STATE HIGHWAYS AND A "STOP" MARKING SHALL BE PLACED ON ALL APPROACHES.
5. IF "STOP AHEAD" (W17A) SIGN IS USED, PAVEMENT MARKINGS SHALL BE PLACED ADJACENT TO THE SIGN.

CITY OF ROCKLIN  
ENGINEERING DIVISION  
TYPICAL

INTERSECTION  
MARKINGS

SCALE: NONE  
DATE: AUGUST 2015  
DRAWN BY: J. PINKHAM

DWG #  
3-31

*[Signature]*  
DRAWING APPROVED - CITY ENGINEER

*[Signature]*  
DRAWING APPROVED - DIRECTOR OF PUBLIC SERVICES

THE DIMENSION OF EACH PARKING SPACE SHALL BE DETERMINED FROM THE FOLLOWING CHART:

OFF-STREET PARKING

ANGLE	STALL WIDTH	STALL TO CURB	AISLE WIDTH (MIN.)	ONE ROW PLUS AISLE	TWO ROWS+ AISLE	STALL LENGTH
$\alpha$	A	B	C	D	E	F
90° <sup>①</sup>	9'-0"	19'-0"	25'-0"***	44'-0"	63'-0"	19'-0"
90° <sup>②</sup>	8'-0"	16'-0"	25'-0"***	41'-0"	57'-0"	16'-0"
60°	9'-0"	21'-0"	19'-0"*	40'-0"	61'-0"	19'-0"
45°	9'-0"	19'-10"	16'-4"*	36'-2"	56'-0"	19'-0"

(D = B+C; E = 2B+C)

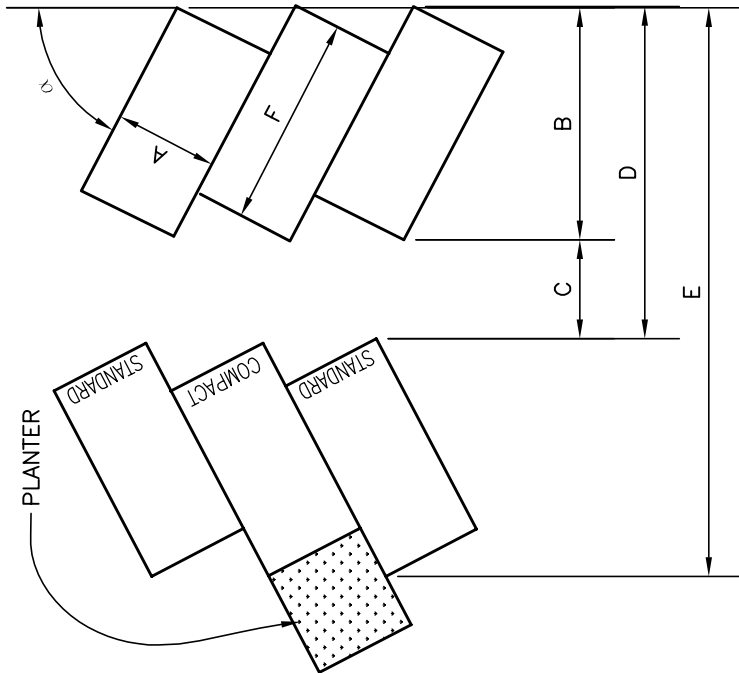

OFF-STREET PARKING LAYOUT

NOTE: MIN. STRUCTURAL SECTION 2" A.C./4" A.B.

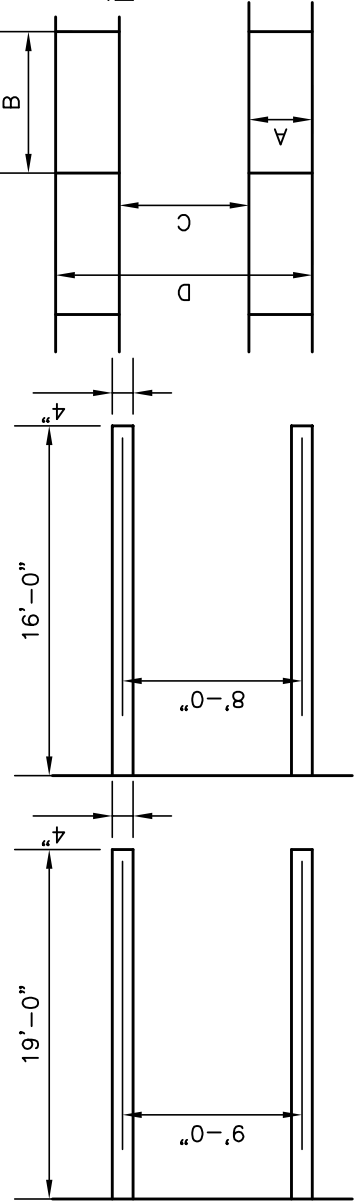

STANDARD PARKING<sup>①</sup>  
SPACE DELINEATION

COMPACT PARKING<sup>②</sup>  
SPACE DELINEATION

PARALLEL PARKING  
SPACE DELINEATION

NOTES:

- \*\* DENOTES TWO WAY AISLE  
\* DENOTES ONE-WAY AISLE
- WHEEL STOPS ARE TO BE PLACED TWO FEET (2') IN FROM EDGE OF PARKING STALL.
- SEE ROCKLIN MUNICIPAL CODE FOR SPACE REQUIREMENTS.

PARALLEL PARKING

STALL WIDTH	STALL LENGTH	AISLE	TWO ROWS+ AISLE
A	B	C	D
9'-0"	24'-0"	12'-0"	30'-0"
9'-6"	24'-0"	12'-0"	31'-0"
10'-0"	24'-0"	12'-0"	32'-0"

DRAWING APPROVED - CITY ENGINEER

DRAWING APPROVED - DIRECTOR OF PUBLIC SERVICES

*[Signature]*

CITY OF ROCKLIN  
ENGINEERING DIVISION

TYPICAL

OFF-STREET  
PARKING

SCALE: NONE  
DATE: AUGUST 2015  
DRAWN BY: J. PINKHAM

DWG #  
3-32

# LEGEND

1. SLOPE OF THE RAMP SHALL BE A MINIMUM OF 6.67% AND A MAXIMUM OF 8.33%. THESE SHALL BE INDICATED ON THE PLANS.
2. TACTILE STRIP. WHEN BREAKING INTO EXISTING CURB, SAW CUT TO NEAREST EXISTING VERTICAL JOINT AND REPLACE. REFER TO LATEST CALTRANS STANDARDS FOR DETAILS.
3. NO LIP
4. TRUNCATED DOME PER LATEST CALTRANS STANDARDS.
5. 12' MIN. AT TYPICAL PARKING STALL. MINIMUM AT VAN ACCESSIBLE PARKING STALL.
6. H.C. STALL SIGN AT EACH STALL.
7. TYPICAL H.C. SYMBOL.
8. STRIPES AT 36" ON CENTER.

*[Signature]*  
DRAWING APPROVED - CITY ENGINEER

*[Signature]*

DRAWING APPROVED - DIRECTOR OF PUBLIC SERVICES  
\*FOR SECTION A-A AND LIP DETAIL SEE CITY OF ROCKKLIN STANDARD DRAWING 3-19.

THESE DETAILS ARE FOR GENERAL GUIDELINES ONLY. ALL HANDICAP PARKING STALLS AND RAMPS MUST CONFORM TO CALIFORNIA CODE OF REGULATIONS (C.C.R.), TITLE 24, PART 2, ADA REQUIREMENTS.

CITY OF ROCKKLIN ENGINEERING DIVISION	
HANDICAP PARKING SPACE LAYOUT DETAIL	
SCALE: NONE	DWG #
DATE: MAY 2016	3-33
DRAWN BY: J. PINKHAM	

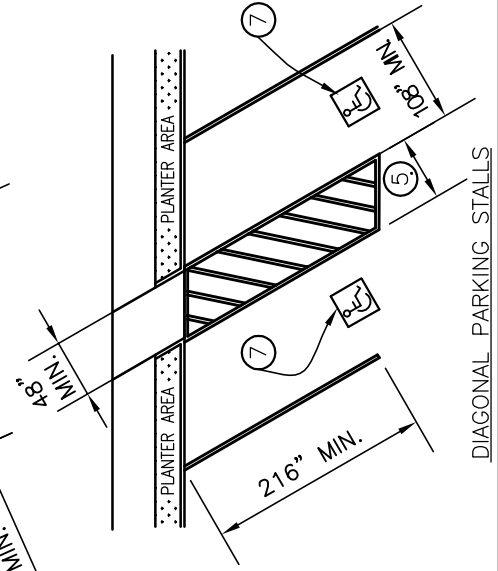
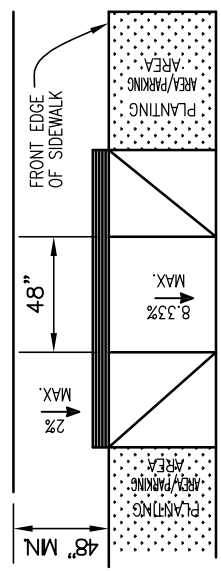
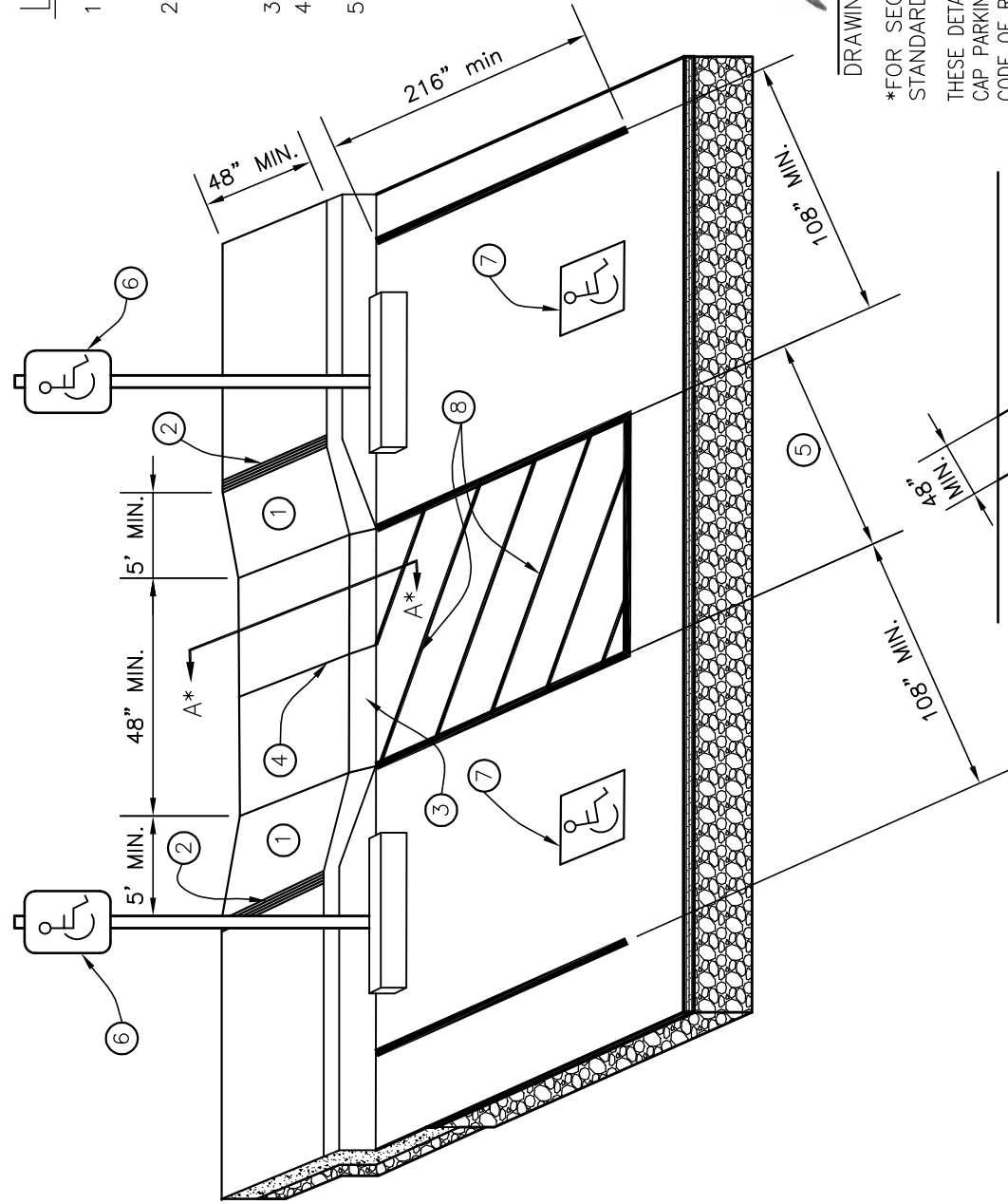

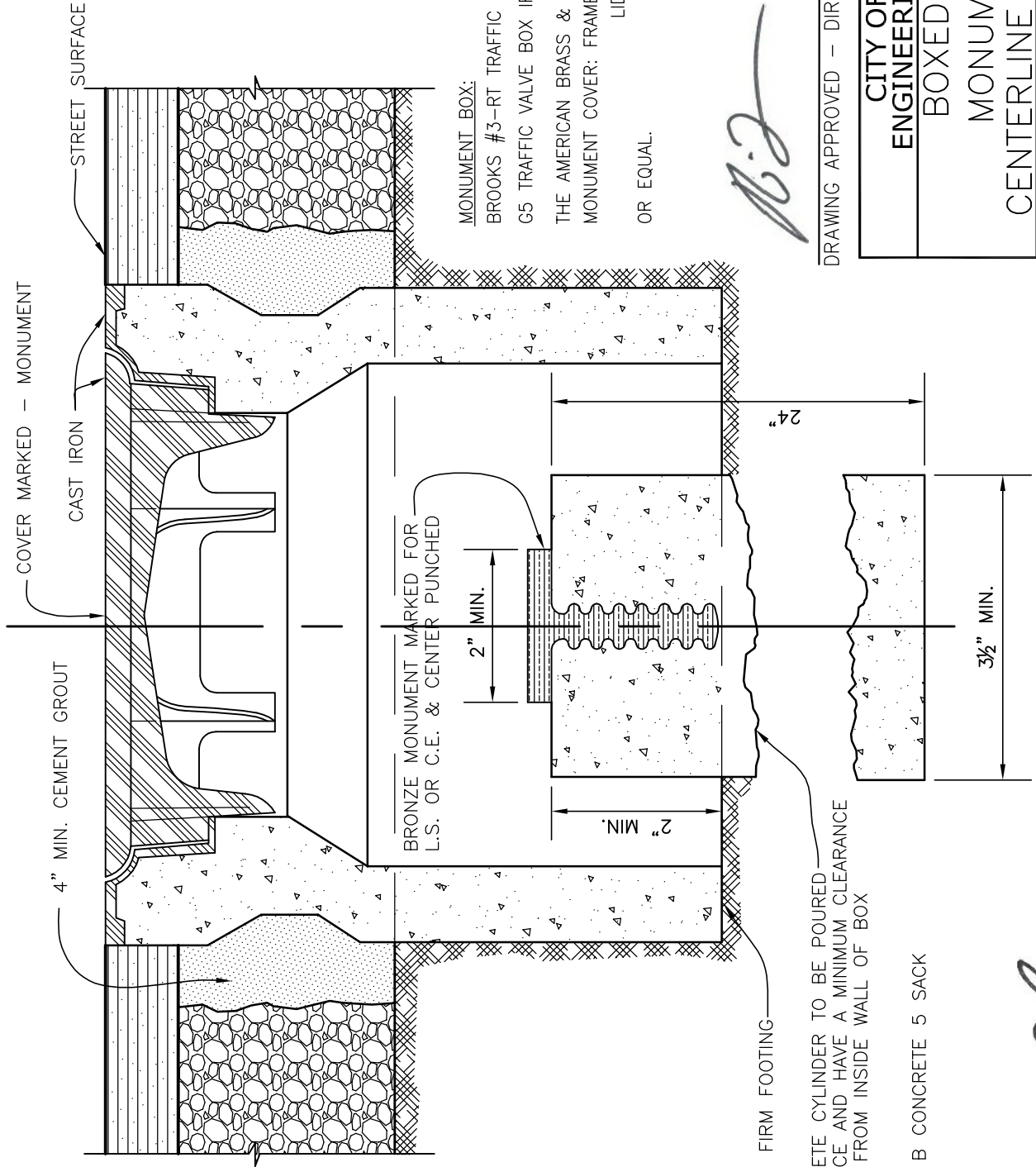

MONUMENT BOX:  
 BROOKS #3-RT TRAFFIC GATE VALVE BOX  
 G5 TRAFFIC VALVE BOX IRON SIDES  
 THE AMERICAN BRASS & IRON FOUNDRY  
 MONUMENT COVER: FRAME 5020  
 LID 5022  
 OR EQUAL.

*A.P.*

CONCRETE CYLINDER TO BE POURED  
 IN PLACE AND HAVE A MINIMUM CLEARANCE  
 OF 1" FROM INSIDE WALL OF BOX

CLASS B CONCRETE 5 SACK

*[Signature]*

DRAWING APPROVED - CITY ENGINEER

DRAWING APPROVED - DIRECTOR OF PUBLIC SERVICES

CITY OF ROCKLIN ENGINEERING DIVISION	
BOXED SURVEY	
MONUMENT FOR CENTERLINE INTERSECTION	
SCALE: NONE	DWG #
DATE: AUGUST 2015	3-34
DRAWN BY: J. PINKHAM	



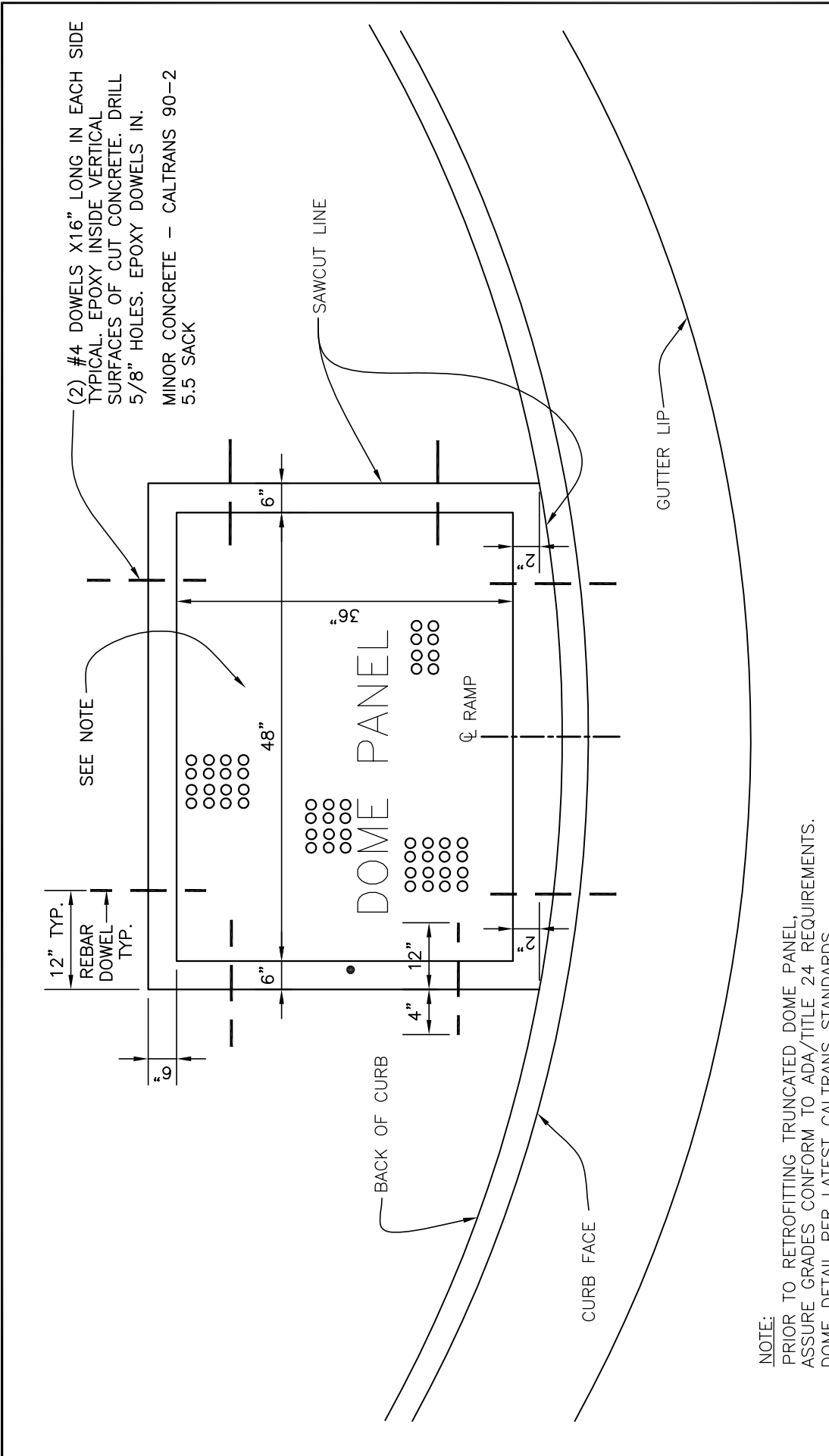

(2) #4 DOWELS X16" LONG IN EACH SIDE  
 TYPICAL. EPOXY INSIDE VERTICAL  
 SURFACES OF CUT CONCRETE. DRILL  
 5/8" HOLES. EPOXY DOWELS IN.  
 MINOR CONCRETE - CALTRANS 90-2  
 5.5 SACK

SEE NOTE

**NOTE:**  
 PRIOR TO RETROFITTING TRUNCATED DOME PANEL,  
 ASSURE GRADES CONFORM TO ADA/TITLE 24 REQUIREMENTS.  
 DOME DETAIL PER LATEST CALTRANS STANDARDS  
 COLOR MUST BE YELLOW

<b>CITY OF ROCKLIN</b>	
<b>ENGINEERING DIVISION</b>	
DETECTABLE WARNING	
TRUNCATED DOME PANEL	
RETROFIT OR REPLACEMENT	
SCALE: NONE	DWG #
DATE: MAY 2016	3-35
DRAWN BY: J. PINKHAM	

*[Signature]*  
 DRAWING APPROVED - CITY ENGINEER

*[Signature]*  
 DRAWING APPROVED - DIRECTOR OF PUBLIC SERVICES

**LEGEND:**

1. 11 GAUGE, 2 3/4" O.D. ROUND STEEL POST WITH CAPPED TOP AND 3/4" HOLES FOR SWIVEL ROD AND 3/4" HOLES FOR LOCKING PIN. EASE ALL EDGES OF STEEL POST.
2. 3/8" DIA. X 6" LOCKING PIN WITH 3/8" HOLES 1/4" FROM EACH END OF PIN OR 3/8" DIA. X 5" LOCKING PIN WITH FLAT WASHER ON ONE END AND 3/8" HOLE 1/4" FROM END OF PIN.
3. PADLOCKS TO BE PROVIDED BY CONTRACTOR.
4. 5/8" DIA. STEEL SWIVEL ROD. WELD SWIVEL ROD TO SIDE PLATES - NO WASHERS.
5. CONCRETE PAVING / ASPHALT. HOLD CONCRETE 2" BELOW FINISHED GRADE. BLACK TOP REST.
6. 3/8" X 16" X 4" STEEL BASE PLATE WITH 1" RADIUS CORNERS. EASE ALL EDGES.
7. 3/8" STEEL BRACE. FILED W/LED BOTH SIDES TO BASE PLATE.
8. 24" ROUND CONCRETE X 18" DEEP FOOTING.
9. COMPACTED SUBGRADE.
10. 1" RADIUS CORNERS, TYP.
11. 1" RED DIAMOND REFLECTIVE TAPE.

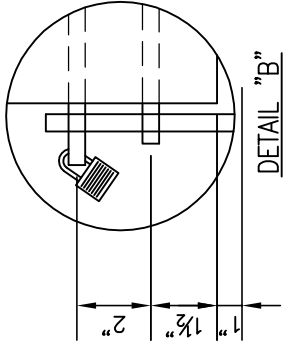

DETAIL "B"

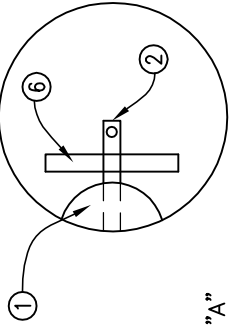

DETAIL "A"

DETAIL "A"

PLAN

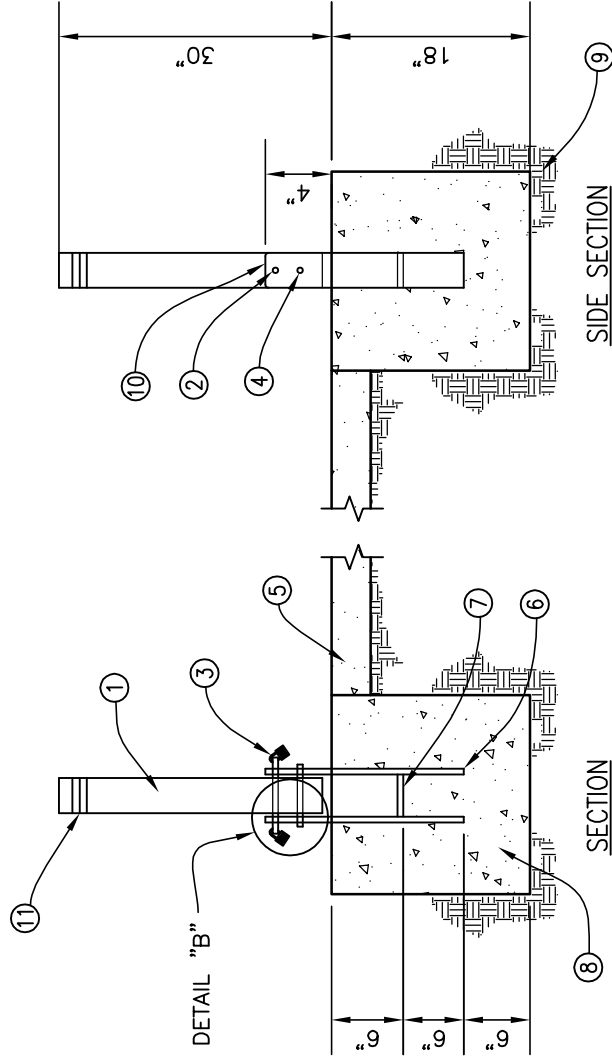

SIDE SECTION

SECTION

**NOTES:**

1. ALL PIPE SHALL BE BLACK STEEL
2. MINOR CONCRETE PER CALTRANS OR CLASS "B"
3. ALL JOINTS SHALL BE WELDED IN ACCORDANCE WITH CA STATE STANDARD SPECIFICATIONS FOR WELDING STRUCTURAL STEEL.
4. ALL PARTS (EXCEPT PADLOCK) SHALL BE PAINTED WITH TWO COATS OF ZINC CHROMATE PRIMER AND TWO COATS OF EXTERIOR ENAMEL. COLOR: YELLOW PER CITY STANDARDS.
5. BOLLARD SHALL BE INSTALLED SUCH THAT WHEN FOLDED IT LAYS FLAT.

*[Signature]*  
DRAWING APPROVED - CITY ENGINEER

*[Signature]*

DRAWING APPROVED - DIRECTOR OF PUBLIC SERVICES

CITY OF ROCKLIN  
ENGINEERING DIVISION

COLLAPSING  
BOLLARD  
DETAIL

SCALE: NONE  
DATE: DECEMBER 2015  
DRAWN BY: J. PINKHAM

DWG #  
3-36

TABLE 1

Length of Longitudinal Buffer Space	Length of Buffer Space in Feet	Speed in Miles Per Hour	Width of Lane
25	155	25	11 Feet
30	200	30	11.5
35	250	35	12.5
40	305	40	180
45	360	45	180
50	425	50	245
55	495	55	245
60	570	60	293
65	645	65	320
70	730	70+	320
		70+	540
		70+	600
		70+	660
		70+	720
		70+	780
		70+	1000

TABLE 2

Length of Longitudinal Buffer Space	Length of Buffer Space in Feet	Speed in Miles Per Hour	Width of Lane
25	155	25	11 Feet
30	200	30	11.5
35	250	35	12.5
40	305	40	180
45	360	45	180
50	425	50	245
55	495	55	245
60	570	60	293
65	645	65	320
70	730	70+	320
		70+	540
		70+	600
		70+	660
		70+	720
		70+	780
		70+	1000

TABLE 3

Speed Limits	Between Signs	Distance in Feet
25 mph or less		100
30 or more		350
Rural		500
Expressway		1000

LEGEND:

- SIGN
- CONE OR PORTABLE DELINEATOR
- DIRECTION OF TRAFFIC
- FLASHING ARROW SIGN

NOTES:

TAPER FORMULA:  
 $L = S \times W$  FOR SPEEDS OF 45 MPH OR MORE  
 $L = \frac{(WS)^2}{60}$  FOR SPEEDS OF 40 MPH OR LESS  
 WHERE:  
 L = MINIMUM LENGTH OF TAPER.  
 S = NUMERICAL VALUE OF POSTED SPEED LIMIT PRIOR TO WORK OR 85 PERCENTILE SPEED.  
 W = WIDTH OF OFFSET.

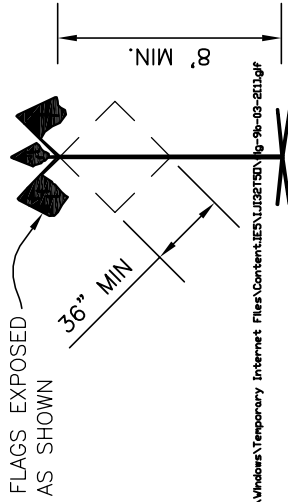
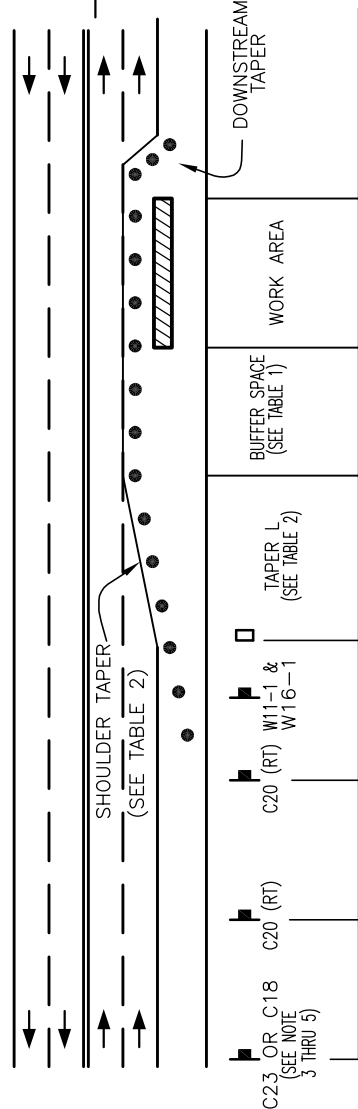

C:\Users\jpinkham\AppData\Local\Microsoft\Windows\Temporary Internet Files\Content.I551J32F15D\lg-9c-09-2011.gif

W11-1 & W16-1  
 (SEE NOTE 9)

ADVANCED WARNING SIGN  
 (2 FLAGS AND MINIMUM DIMENSIONS MANDATORY)

SPECIAL NOTES:

THIS DETAIL IS REPRODUCED FROM FIGURE 6C-1 OF THE CALIFORNIA MANUAL ON UNIFORM TRAFFIC CONTROL DEVICES 2012 EDITION, CHAPTER 6-TEMPORARY TRAFFIC CONTROL. FIELD CONDITIONS COULD REQUIRE DEVIATIONS FROM THESE PLANS AND ACCOMPANYING NOTES.

NOTES:

1. THIS PLAN DOES NOT APPLY WHERE THERE ARE EMERGENCY CONDITIONS. UNDER EMERGENCY CONDITIONS, EQUIPMENT AND PERSONNEL WHICH ARE AVAILABLE SHOULD BE UTILIZED TO IMPLEMENT A CLOSURE, EVEN THOUGH SUCH CLOSURE DOES NOT MEET THE STANDARDS CONTAINED IN THIS PLAN. AS EQUIPMENT OR PERSONNEL BECOME AVAILABLE, AN IMMEDIATE EFFORT SHOULD THEN BE MADE TO IMPLEMENT THE STANDARDS SHOWN ON THIS PLAN.
2. ALL ADVANCE WARNING SIGNS SHALL BE 36" X 36" MINIMUM. (SEE NOTE 4)
3. ALL WARNING SIGNS FOR NIGHT CLOSURES SHALL BE EITHER ILLUMINATED OR RETROREFLECTORIZED.
4. A C18 "ROAD CONSTRUCTION AHEAD" SIGN MAY BE USED IN LIEU OF THE C23. (SEE NOTE 2)
5. WARNING (W) SERIES SIGNS USED IN WORK ZONES SHALL BE BLACK ON ORANGE. EXISTING YELLOW WARNING SIGNS ALREADY IN PLACE WITHIN THESE AREAS SHALL REMAIN IN USE.
6. PAVEMENT MARKINGS FOR CLOSURES SHALL CONFORM TO SECTION 6 OF THE CAMUTCD 2006 EDITION AND CALTRANS STANDARD PLANS.
7. ALL CONES SHALL BE INTERNALLY ILLUMINATED OR FITTED WITH RETROREFLECTIVE WHITE SLEEVES FOR NIGHT CLOSURES. (SEE SECTION 6-6F.59 OF THE CAMUTCD)
8. THE MAXIMUM SPACING BETWEEN CHANNELIZING DEVICES IN A TAPER SHOULD BE APPROXIMATELY EQUAL TO THE SPEED LIMIT.
9. W11-1 AND W16-1 REQUIRED ONLY WHEN TAPER CROSSES A MARKED BICYCLE LANE.

DRAWING APPROVED - CITY ENGINEER

DRAWING APPROVED - DIRECTOR OF PUBLIC SERVICES

CITY OF ROCKLIN  
 ENGINEERING DIVISION  
 TYPICAL TRAFFIC  
 CONTROL LANE  
 CLOSURE/TRANSITION

SCALE: NONE  
 DATE: AUGUST 2015  
 DRAWN BY: J. PINKHAM

DWG #  
 3-37

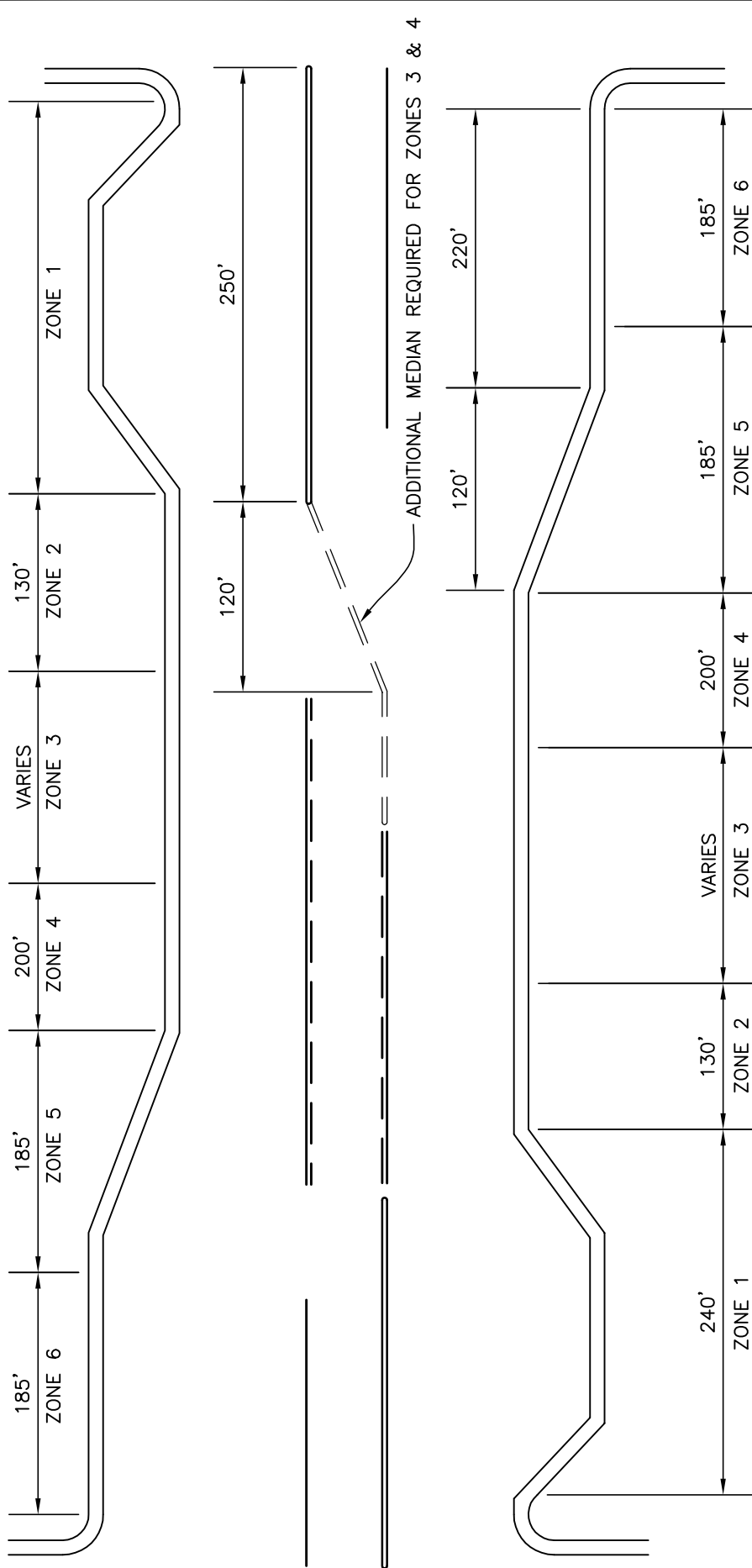

- ZONE 1 NO DRIVEWAYS OR STREETS ALLOWED.
- ZONE 2 DRIVEWAYS AND STREETS ALLOWED. LEFT TURNS OUT ARE PROHIBITED. WHERE THE ADJACENT STREET WILL HAVE DUAL LEFT TURN LANES. ZONE 2 SHALL BE INCREASED TO 190'
- ZONE 3 DRIVEWAYS AND STREETS ALLOWED. ALL TURNING MOVEMENTS PERMITTED.
- ZONE 4 DRIVEWAYS AND STREETS ALLOWED. LEFT TURNS IN AND OUT PROHIBITED. ADDITIONAL MEDIAN REQUIRED.
- ZONE 5 DRIVEWAYS ARE ALLOWED. STREETS ARE PROHIBITED. LEFT TURNS IN AND OUT ARE PROHIBITED. ADDITIONAL MEDIAN REQUIRED.
- ZONE 6 NO DRIVEWAYS OR STREETS ALLOWED.

NOTES:  
 1. OPPOSING DRIVEWAYS SHOULD ALIGN WITH EACH OTHER. IF NOT, SEE ST-47 FOR MINIMUM OFFSETS.  
 2. SEE DETAIL ST-48 AND ST-49 FOR DRIVEWAYS NEAR BUS TURNOUTS.

*[Signature]*

DRAWING APPROVED - DIRECTOR OF PUBLIC SERVICES

CITY OF ROCKKLIN  
 ENGINEERING DIVISION  
 PERMITTED DRIVEWAYS  
 OR STREETS  
 ON MINOR ARTERIALS

SCALE: NONE  
 DATE: DECEMBER 2015  
 DRAWN BY: J. PINKHAM  
 DWG # 3-38

*[Signature]*  
 DRAWING APPROVED - CITY ENGINEER

PLASTIC EXPANSION CAP SHALL BE INSTALLED DURING CONCRETE POUR, THEN REMOVED AFTER CONCRETE HAS CURED A MINIMUM OF 24 HOURS. THEN APPLY JOINT SEALANT TO JOINT.

\*\*\*SNAP CAPS REQUIRED ON SIDEWALK ONLY, NOT IN CURB OR CURB AND GUTTER.

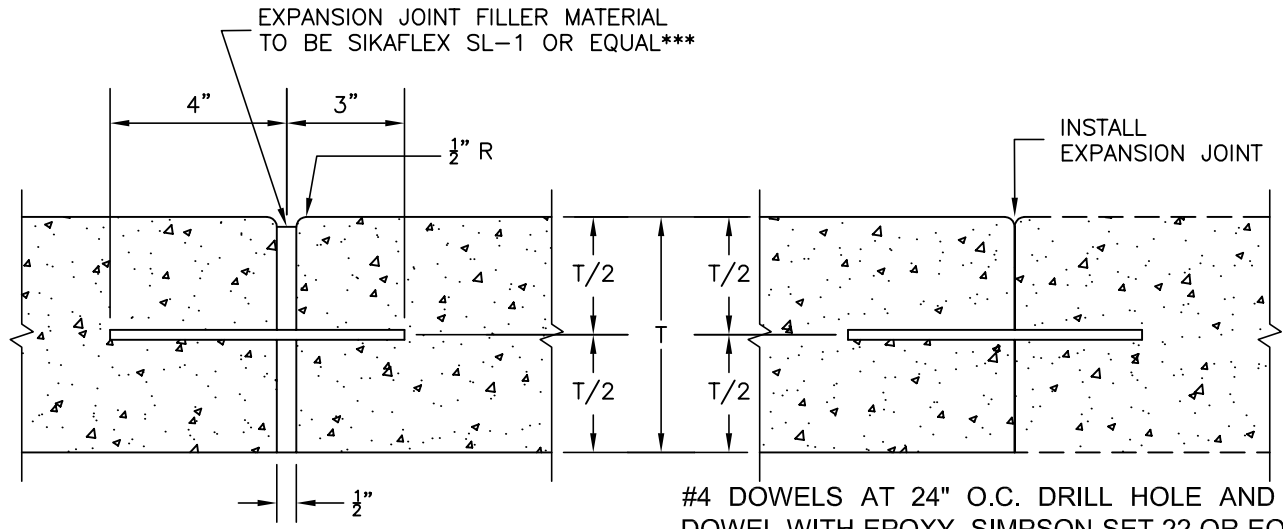

#4 DOWELS AT 24" O.C. DRILL HOLE AND SET DOWEL WITH EPOXY. SIMPSON SET 22 OR EQUAL. GREASE OTHER END.

**EXPANSION JOINT**  
**AT 20' O.C. MAX**

**SIDEWALK CONTACT JOINT**

USE WHERE NEW CONSTRUCTION OF SIDEWALK, RAMP, AND/OR CURB AND GUTTER ABUTS EXISTING IMPROVEMENTS.

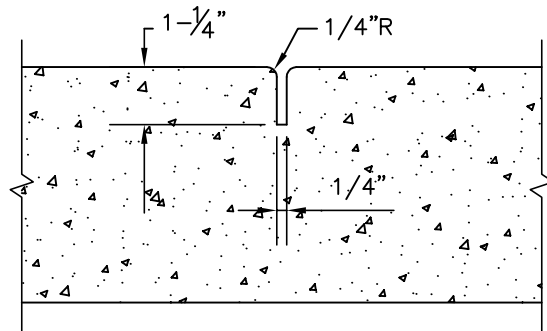

**WEAKENED PLANE JOINT**  
**AT 10' O.C. MAX**

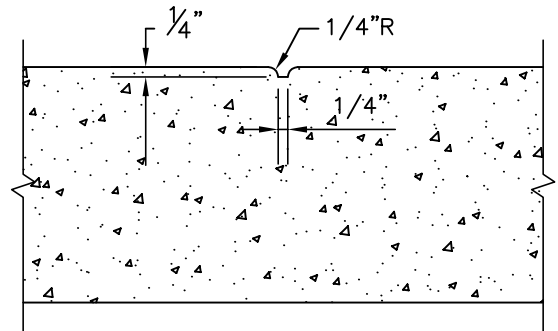

**SCORE MARK**

  
DRAWING APPROVED - CITY ENGINEER

  
DRAWING APPROVED - DIRECTOR OF PUBLIC SERVICES

CITY OF ROCKLIN ENGINEERING DIVISION	
STANDARD CONCRETE JOINT DETAILS	
SCALE: NONE DATE: MAY 2016 DRAWN BY: J. PINKHAM	DWG # 3-39

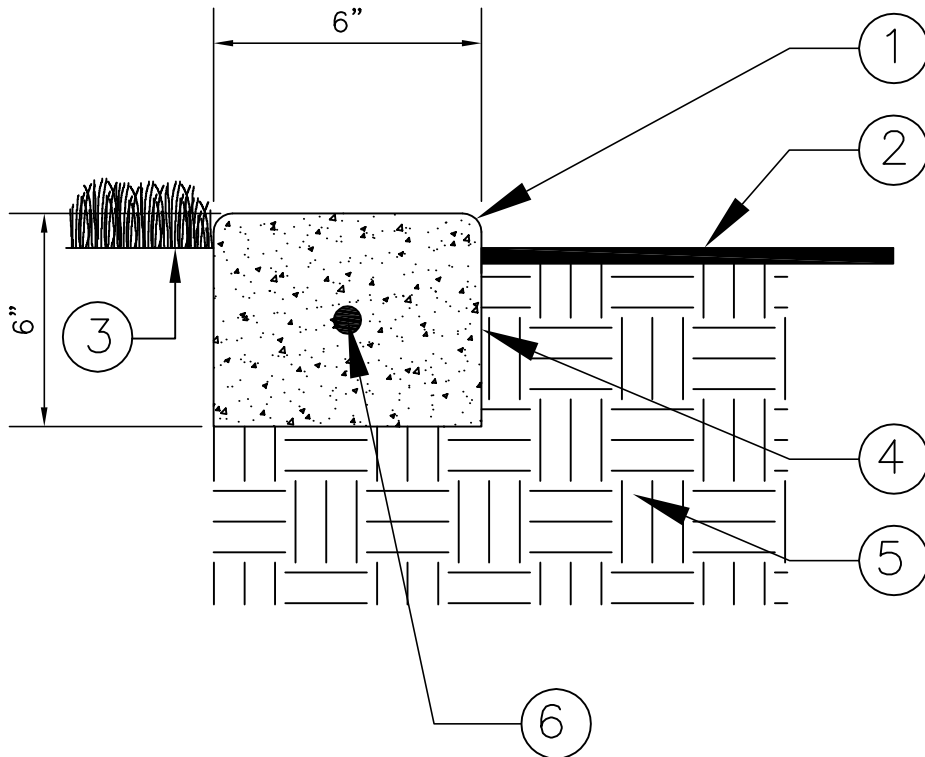

**LEGEND:**

1. 1/4" RADIUS TOOLED EDGE.
2. FINISH GRADE 1" BELOW TOP OF BAND FOR TURF AND 2" BELOW TOP OF BAND FOR SHRUBS AND/OR GROUND COVER.
3. FINISH GRADE IN SHRUB AREA
4. 6"X6" CONCRETE MOW BAND.
5. COMPACTED SUB-GRADE TO 90%.
6. #4 REBAR, CONTINUOUS WITH 18" OVERLAP MINIMUM

**NOTE:**

- A. PROVIDE EXPANSION JOINTS AT 20" ON CENTER

CITY OF ROCKLIN  
ENGINEERING DIVISION

MOW BAND

SCALE: NONE  
DATE: MAY 2016  
DRAWN BY: J. PINKHAM

DWG #  
3-40

*[Signature]*  
DRAWING APPROVED - CITY ENGINEER

*[Signature]*  
DRAWING APPROVED - DIRECTOR OF PUBLIC SERVICES

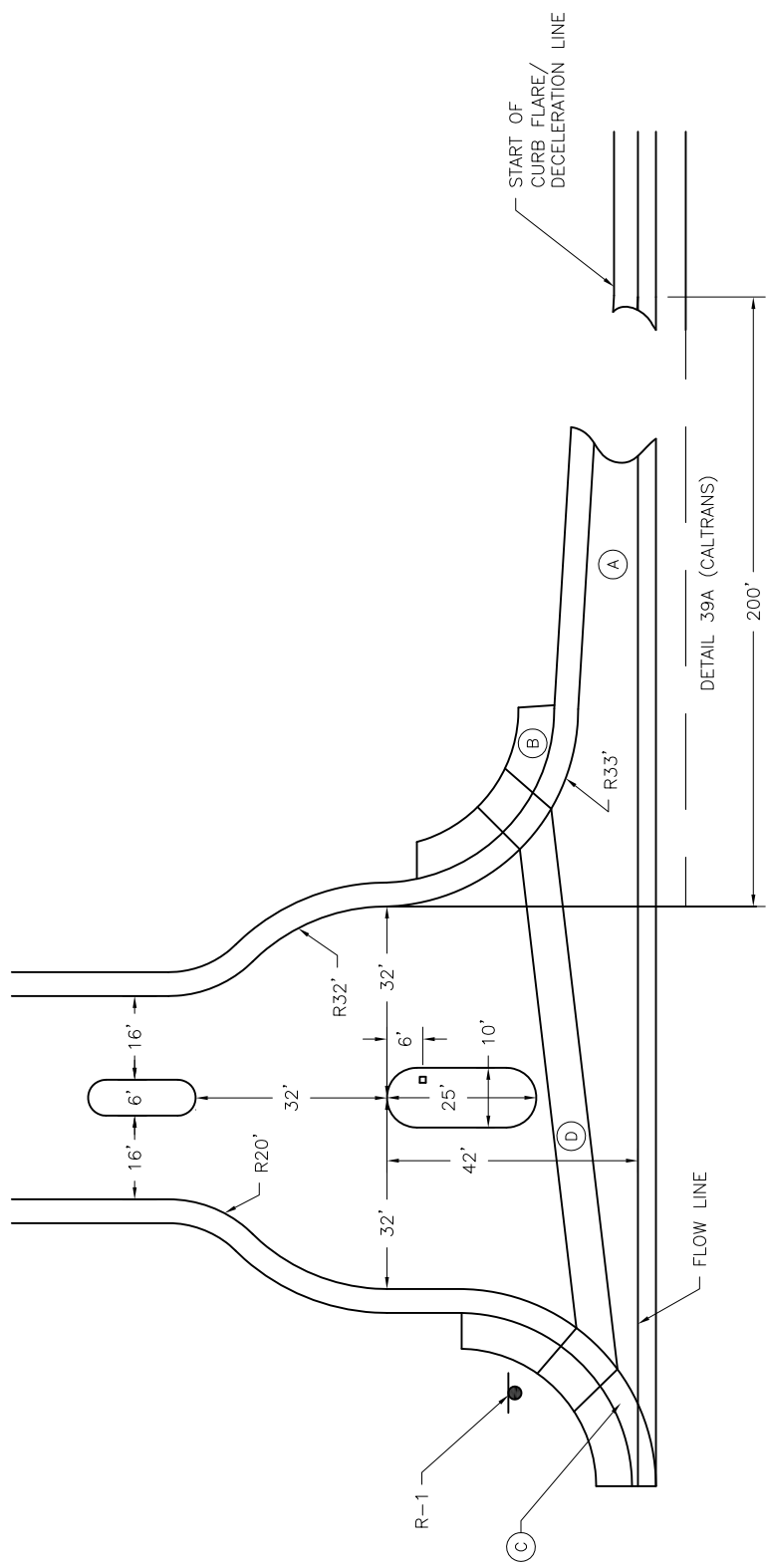

- LEGEND:**
- A. CURB FLARE OR DECLARATION LANE.
  - B. SIDEWALK WIDTH PER PLANS, 5 FOOT MINIMUM.
  - C. CURB AND GUTTER TO BE "TYPE 1".
  - D. PLACE CROSS WALK

- NOTES:**
- 1. STRIPING AND SIGNAGE TO COMPLY WITH LATEST EDITION OF CAMUTCD
  - 2. DRIVEWAYS WHERE THE MEDIAN IS NOT BROKEN SHALL HAVE THE DETAIL 39 CONTINUE THROUGH THE CURB FLARE AND DRIVEWAY.

*[Signature]*  
 DRAWING APPROVED – CITY ENGINEER

*[Signature]*  
 DRAWING APPROVED – DIRECTOR OF PUBLIC WORKS

<b>CITY OF ROCKLIN ENGINEERING DIVISION</b>	
PRIVATE GATED ENTRANCE	
<b>SCALE: NONE</b>	<b>DWG #</b>
<b>DATE: 04/29/16</b>	<b>3-41</b>
<b>DRAWN BY: J. PINKHAM</b>	

# BARBED WIRE SHALL NOT BE USED

FOR TYPES AND SIZES, SEE FENCE MEMBERS TABLE HEREIN.

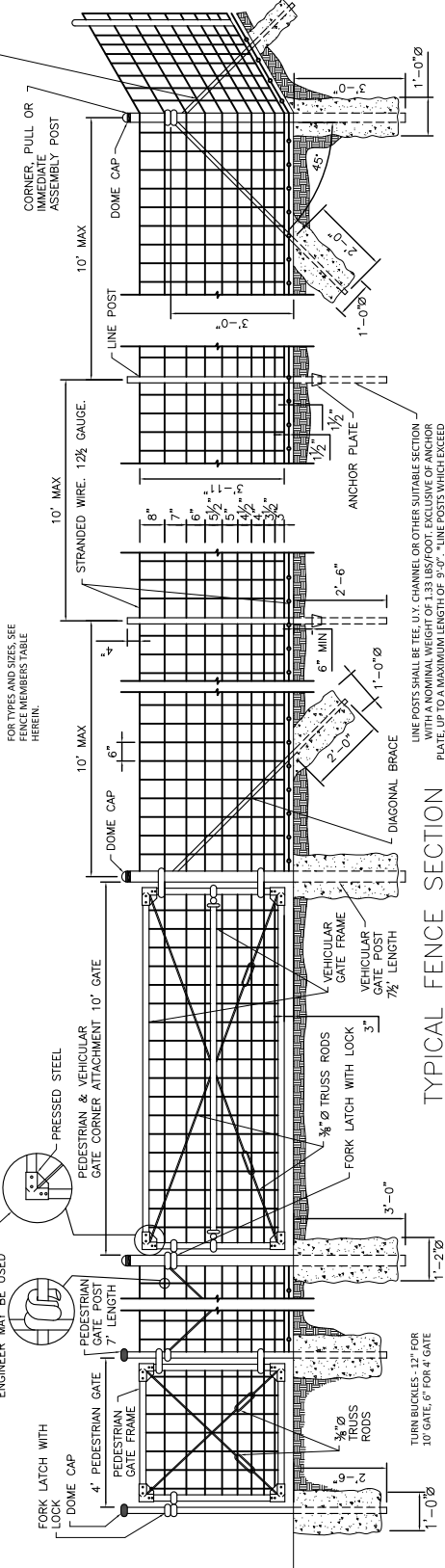

TYPICAL FENCE SECTION

LINE POSTS SHALL BE TEE, U, CHANNEL OR OTHER SUITABLE SECTION WITH A NOMINAL WEIGHT OF 133 LBS/FOOT EXCLUSIVE OF ANCHOR PLATE, UP TO A MAXIMUM LENGTH OF 9'-0". LINE POSTS WHICH EXCEED 9'-0" IN LENGTH, SHALL BE PIPE POSTS, SET IN CONCRETE FOOTINGS.

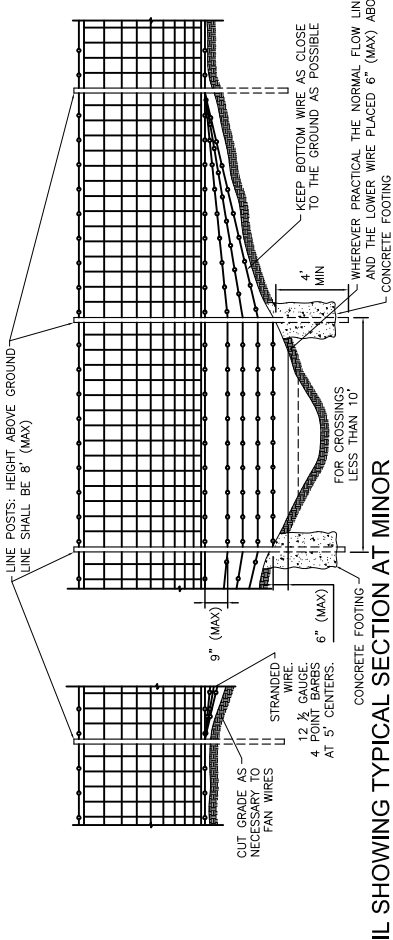

DETAIL SHOWING TYPICAL SECTION AT MINOR DEPRESSIONS AND WET WEATHER CROSSINGS

## NOTES

- Except for "normal length" line posts, all other posts and their diagonal braces shall be either galvanized steel pipe members or triple-coated steel pipe members as shown in the "Fence Members Table" herein. When galvanized pipe posts are used, galvanized pipe diagonal braces shall be used. When triple-coated pipe posts are used, triple-coated pipe diagonal braces shall be employed. Gate frames may be either galvanized pipe members or triple-coated pipe members. All other metal components of gates shall be galvanized, with the exception of die-cast aluminum corner fittings, pressed steel corner fittings. Unless otherwise specified, or directed by the Engineer, the farm field may be installed with the fence fabric and barbed wire corner fittings.
- In lieu of the barbed wire detailed herein, the following additional types are acceptable, provided they retain the "4-point barb at 5-inch centers" requirement and provided they meet or exceed the strength and coating requirements for the stranded, 12 1/2 gauge, barbed wire as called for in 712.10 of the specifications:
  - (a) stranded, 15 1/2 gauge, high carbon steel barbed wire.
  - (b) one-strand, 12 gauge, steel barbed wire. Dome caps for end, corner gate, line or pulposts, shall be swage fitted or securely attached to the posts by means of set screws, pins or rivets.
- Hardware and miscellaneous fittings, not specifically designated herein as to type or dimensions, shall conform to the applicable requirements of 608 of the Specifications and shall be a good quality commercial design acceptable to the Engineer. Drainage structure terminal installations shall be installed as called for on the Plans and/or as shown on typical fence details. Dumped rock channel protection shall be used at channel crossing when called for on the Plans. Type FW-4-5 Nicopress Oval/Sleeve Wire Splices, or other equal sleeve splices approved by the Engineer, may be used in lieu of the "Typical Wire Fence Splice" shown herein.

DRAWING APPROVED - CITY ENGINEER *[Signature]*  
 DRAWING APPROVED - DIRECTOR OF PUBLIC WORKS *[Signature]*

### FENCE MEMBERS TABLE

Member Designation	Galvanized Pipe		Triple-Coated Pipe	
	I.D. In.	Wt. lb/ft.	Wall Thk. In.	Wt. lb/ft. (min.)
End, Pull, Corner and Intermediate Assembly Post	2	0.154	3.65	3.11
Diagonal Brace	1.25	0.14	2.27	1.83
Pedestrian Gate Post	1	0.133	1.68	1.34
Vehicle Gate Post	3.5	0.226	9.11	-
Vehicle Gate Frame	1.5	0.145	2.72	1.5
Special Length Line Post (For over 9'-0")	2	0.154	3.65	3.11

CITY OF ROCKLIN  
 ENGINEERING DIVISION  
 RW FENCE-FARM  
 WITH STEEL POSTS

SCALE: NONE  
 DATE: 03/09/2016  
 DRAWN BY: J. PINKHAM

DWG #  
 3-42



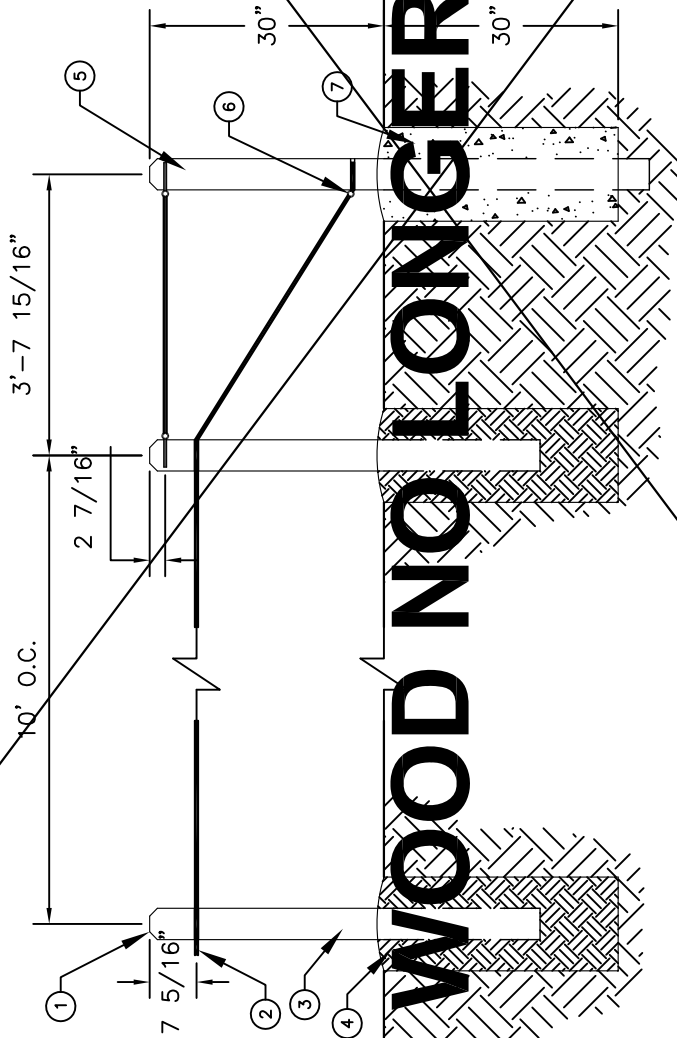



LEGEND:

1. 1" CHAMFER ALL AROUND.
2. 3/8" DIA. 7 STRAND GALV. CABLE, TYP. SLIP THROUGH 1/2" DIA. HOLE IN LINE POSTS OR CONNECT TO EYE BOLTS.
3. LINE POST - 6" X 6" PT "SUNWOOD" WOOD.
4. BACKFILL WITH AGGREGATE BASE TO 95% RELATIVE COMPACTION.
5. CONNECTION LINE POSTS TO TERMINAL POSTS - 6" X 6" PT "SUNWOOD" WOOD.
6. 3/8" DIA. 7 STRAND GALV. CABLE WITH EYE BOLTS FOR SPLICES AND CONNECTIONS. COUNTER-SINK ALL BOLTS.
7. CONCRETE FOOTING AT TERMINAL POSTS.

**WOOD NO LONGER ACCEPTED**

CITY OF ROCKLIN ENGINEERING DIVISION	
WOOD POST AND CABLE FENCE	
SCALE: NONE	DWG #
DATE: DECEMBER 2015	3-43
DRAWN BY: J. PINKHAM	

  
 DRAWING APPROVED - CITY ENGINEER  
  
 DRAWING APPROVED - DIRECTOR OF PUBLIC WORKS

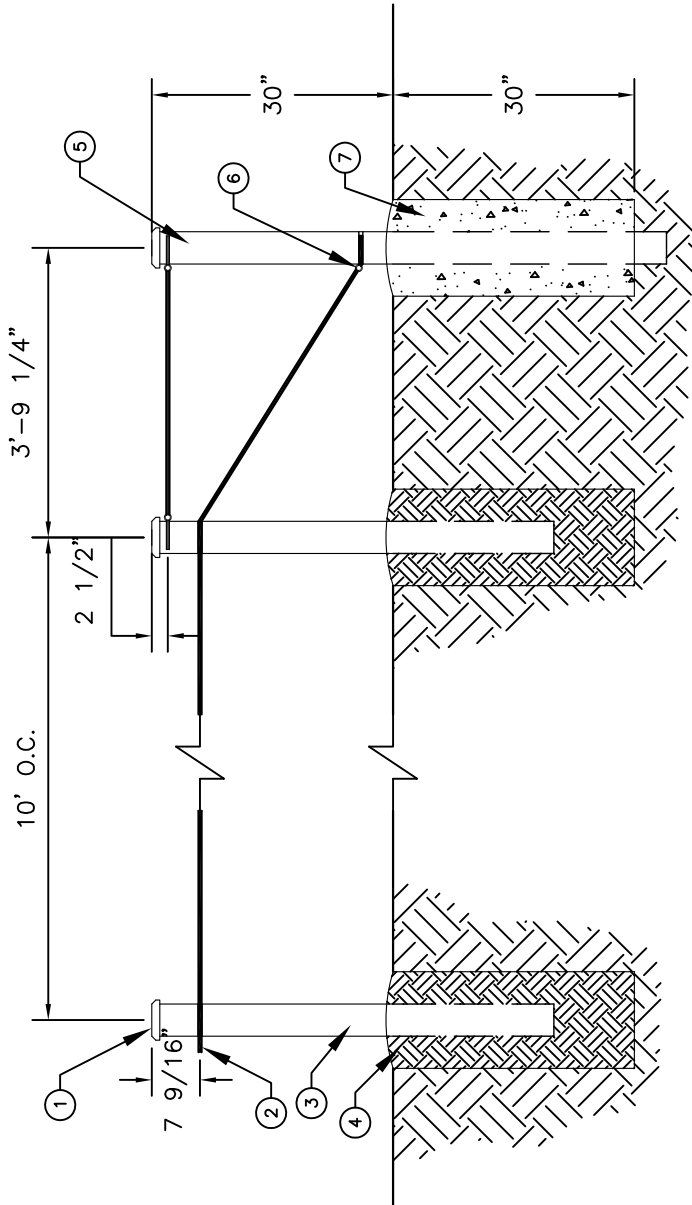

LEGEND:

1. PRESSED STEEL CAP
2. 3/8" DIA. 7 STRAND GALV. CABLE, TYP. SLIP THROUGH 1/2" DIA. HOLE IN LINE POSTS OR CONNECT TO EYE BOLTS.
3. LINE POST - 4" X 4" POWDERCOATED TUBULAR STEEL (COLOR TO BE DETERMINED BY STAFF.)
4. BACKFILL WITH AGGREGATE BASE TO 95% RELATIVE COMPACTION AT LINE POSTS.
5. TERMINAL POST - 4" X 4" POWDERCOATED TUBULAR STEEL (COLOR TO BE DETERMINED BY STAFF.)
6. 3/8" GALV. EYE BOLT WITH GALV. CLAMPS FOR SPLICES AND CONNECTIONS.
7. CONCRETE FOOTING AT TERMINAL POSTS AND EVERY 10TH LINE POST.

CITY OF ROCKKLIN  
ENGINEERING DIVISION

TUBULAR STEEL

POST AND CABLE FENCE

SCALE: NONE

DATE: DECEMBER 2015

DRAWN BY: J. PINKHAM

DWG #

3-44

*[Signature]*  
DRAWING APPROVED - CITY ENGINEER

*[Signature]*  
DRAWING APPROVED - DIRECTOR OF PUBLIC WORKS

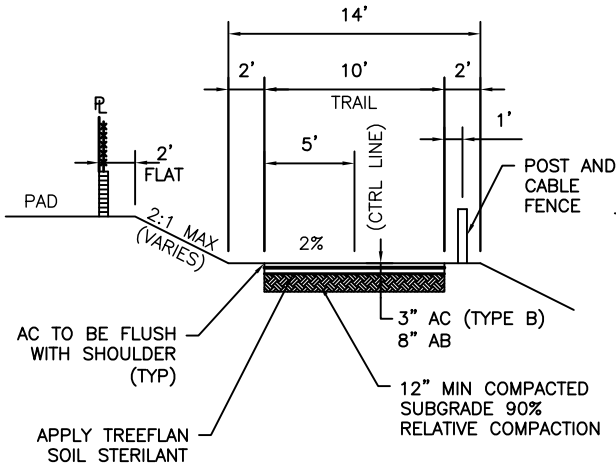

SECTION H  
NTS

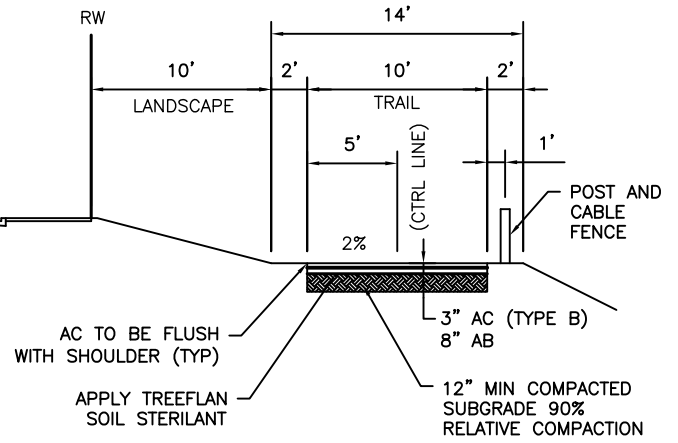

SECTION I  
NTS

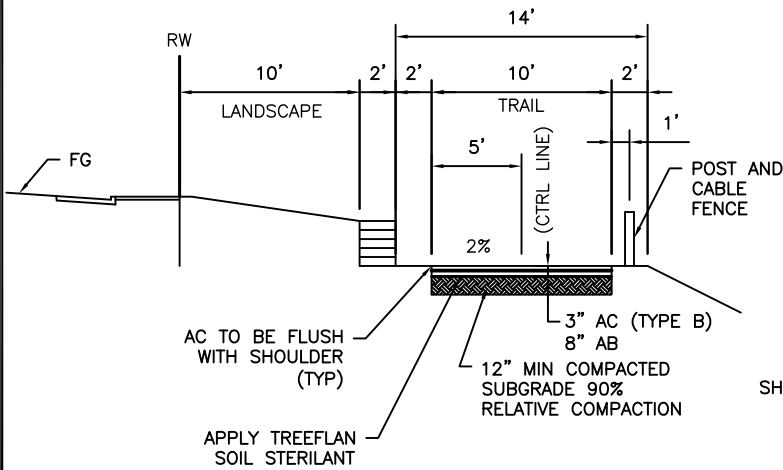

SECTION J  
NTS

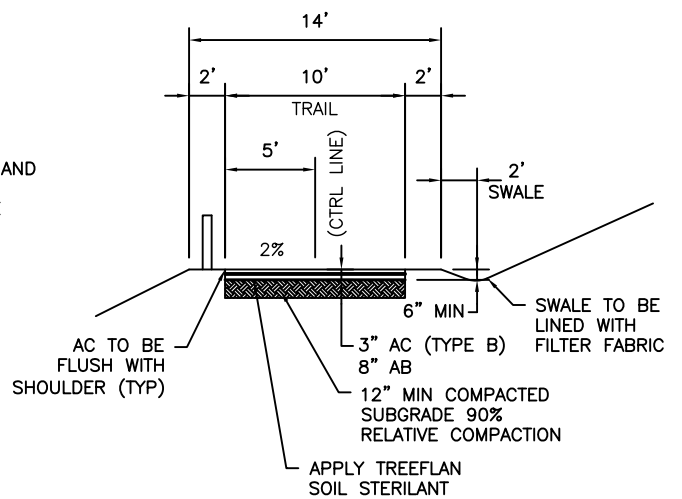

SECTION K  
NTS

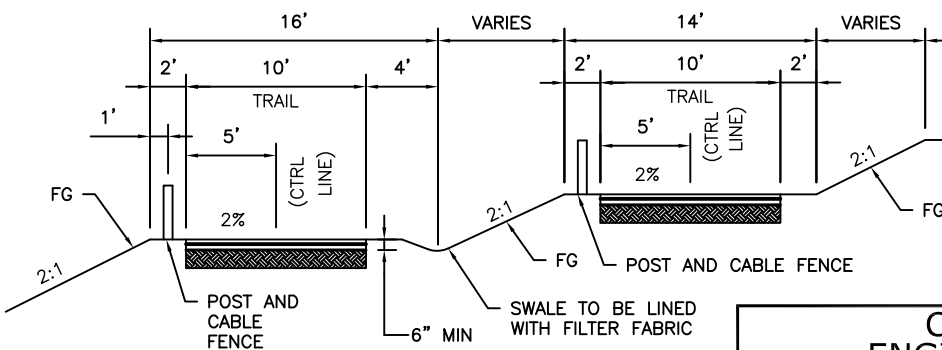

SECTION L  
NTS

*[Signature]*  
DRAWING APPROVED - CITY ENGINEER

*[Signature]*  
DRAWING APPROVED - DIRECTOR OF PUBLIC WORKS

CITY OF ROCKLIN ENGINEERING DIVISION	
AC PEDESTRIAN TRAIL	
SCALE: NONE	DWG #
DATE: DECEMBER 2015	3-45
DRAWN BY: J. PINKHAM	

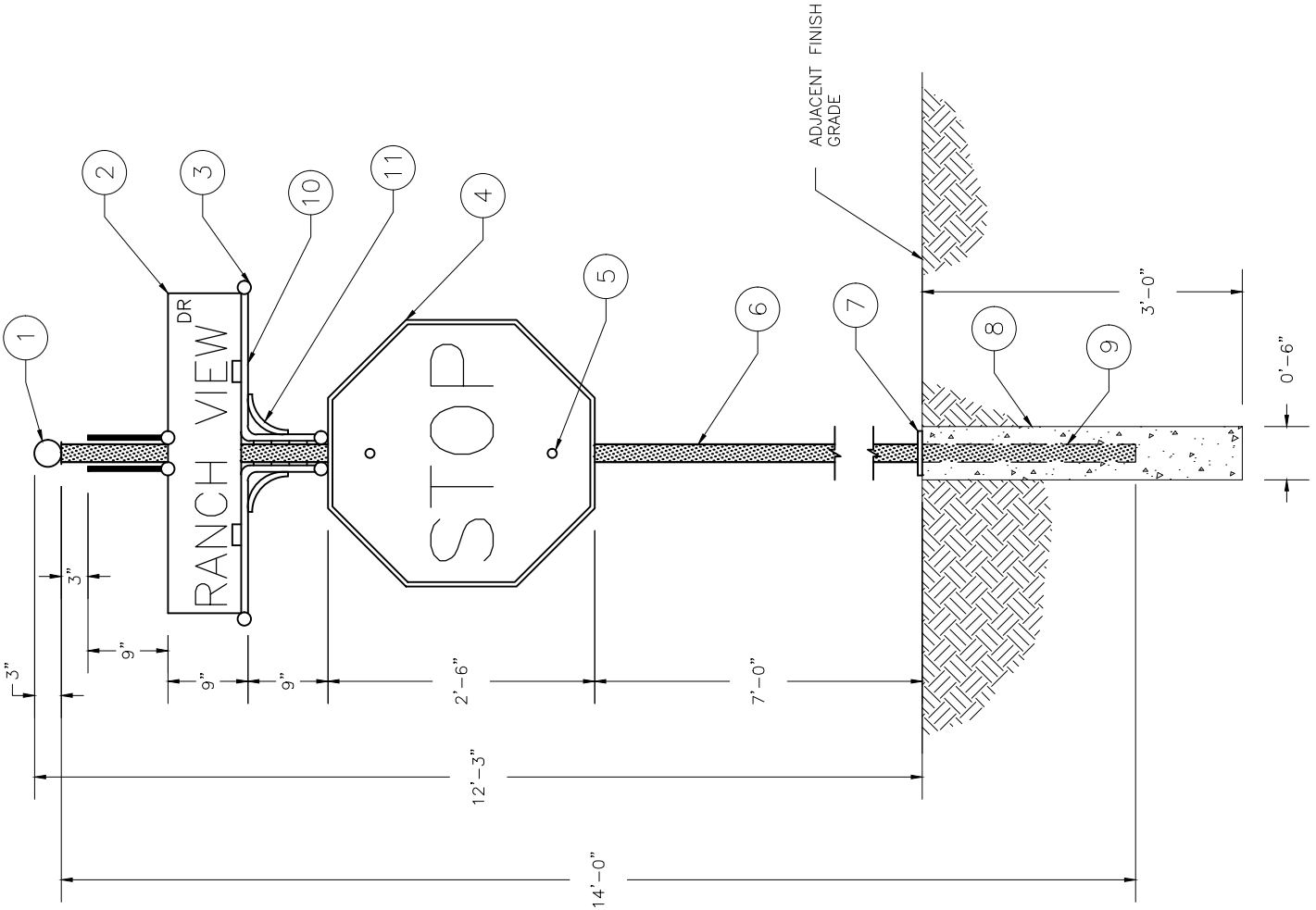

NOTES:

1. 3" DIAMETER-10 GAUGE BALL WELDED TO 2" X 2" X 16" GAUGE PRESS STEEL CAP
  2. CITY OF ROCKLIN STANDARD SIGN BLADE (8" X 36" W/ 6" HIGH, SERIES D UPPERCASE LETTERS, HIGHWAY FONT). IN THE EVENT THE STREET NAME IS TOO LONG FOR A 36" LONG SIGN, THE NEXT LOWER SERIES TEXT (SERIES C OR B) CAN BE USED.
  3. 1 1/2" DIAMETER BALL-TYPICAL
  4. STANDARD R1 STOP SIGN (30" X 30") WITH 7" CLEARANCE TO BOTTOM OF SIGN AND THE ADJACENT FINISH GRADE PER MUTCD.
  5. ATTACH WITH RIVETS
  6. 2" X 14' 12-GAUGE SQ. POST (NO HOLES) POWDER COATED BLACK W/BREAK-A-WAY BASE.
  7. BREAK AWAY BOLT PER CITY OF ROCKLIN SPECIFICATIONS.
  8. 36" DEEP (6"Ø) CONCRETE POST BASE W/27" MIN. SLEEVE. SLEEVE TO BE EMBEDDED 24" PER CITY OF ROCKLIN DETAIL 3-28
  9. SLEEVE TO RECEIVE 2" SQUARE POST.
  10. 3/4"Ø X 24-7/16" LONG ROD.
  11. 1/2"Ø X 7-11/16" LONG ROD.
- FINISH NOTE:  
THE ITEMS SPECIFIED IN NOTES 1, 3, 6, 10 AND 11 SHALL BE POWDER COATED BLACK.
- DECORATIVE STEEL BALL SPECS:  
MFG: KING ARCHITECTURAL 3" DIAMETER 10 GAUGE BALL CATALOG #13-30HBL  
1-1/2" DIAMETER 10 GAUGE BALL CATALOG #13-112

*[Signature]*  
DRAWING APPROVED - CITY ENGINEER

*[Signature]*

DRAWING APPROVED - DIRECTOR OF PUBLIC WORKS

CITY OF ROCKLIN  
ENGINEERING DIVISION

OVERALL SIGN  
CONFIGURATION  
FRONT VIEW

SCALE: NONE

DATE: 05/03/16

DRAWN BY: J.PINKHAM

DWG #  
3-46

NOTES:

- 1: 1-1/2" DIAMETER STEEL BALL (TYP.) 10 GAUGE
- 2: 3/4" DIAMETER ROD (TYPICAL)
- 3: SIGN BLADE HOLDER PER TYPICAL "A" STANDARD 3-48.
- 4: BRACKETS WELDED TO POST

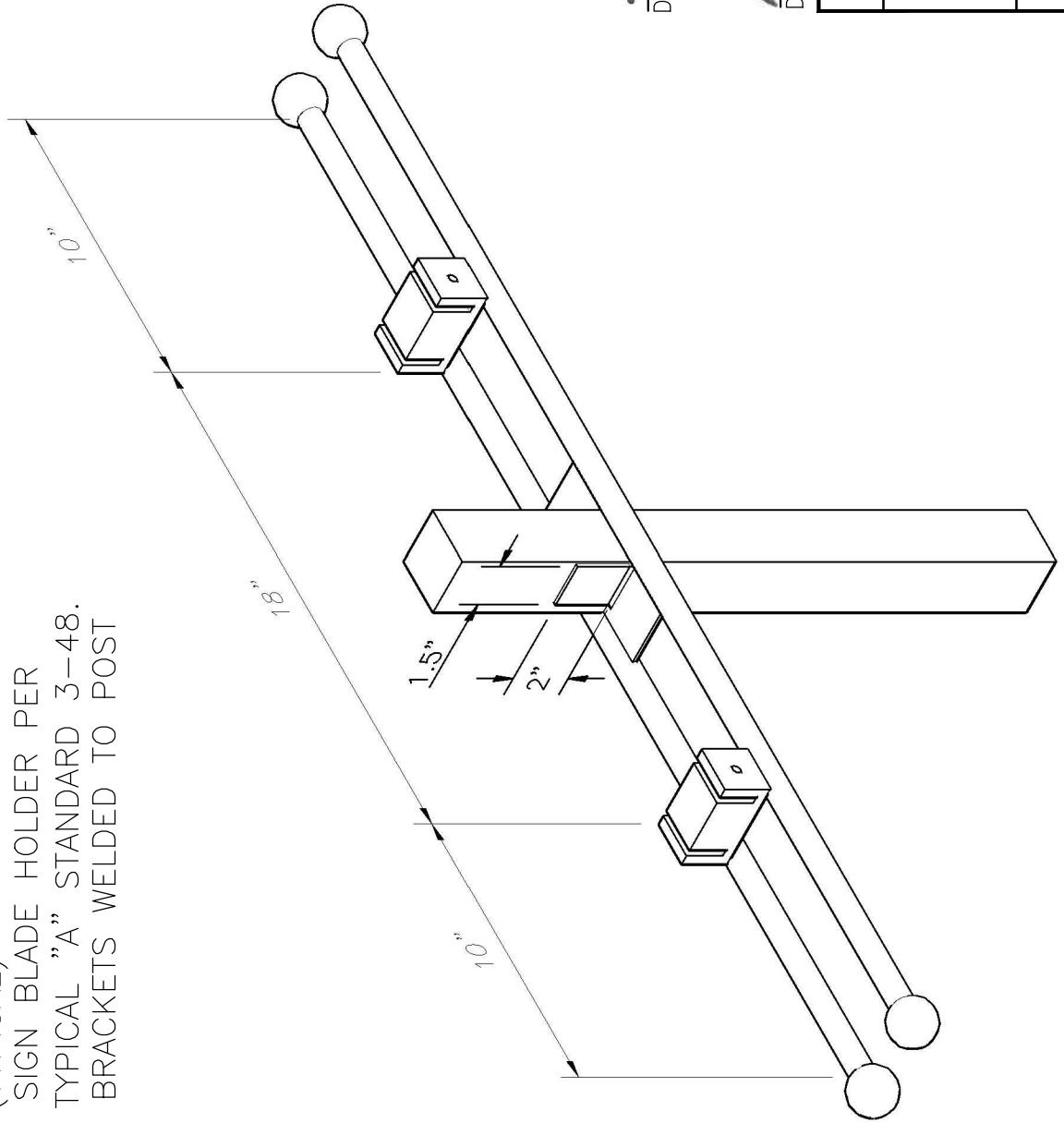

FINISH NOTE:

THE ITEMS SPECIFIED IN NOTES 1-4 SHALL BE POWDER COATED BLACK.

DECORATIVE STEEL BALL SPECS:  
 MFG: KING ARCHITECTURAL  
 3" DIAMETER 10 GAUGE BALL  
 CATALOG #13-30HBL  
 1-1/2" DIAMETER 10 GAUGE  
 BALL CATALOG #13-112

DRAWING APPROVED - CITY ENGINEER

DRAWING APPROVED - DIRECTOR OF PUBLIC WORKS

CITY OF ROCKKLIN  
 ENGINEERING DIVISION

TOP SIGN  
 BRACKET  
 CONFIGURATION

SCALE: NONE

DATE: 05/03/16

DRAWN BY: J.PINKHAM

DWG #

3-47

NOTES:

- 1: 1-1/2" DIAMETER STEEL BALL (TYP.) 10 GAUGE
- 2: 3/4" DIAMETER ROD
- 3: 1/2" DIAMETER ROD
- 4: BRACKETS WELDED TO POST
- 5: SIGN BLADE HOLDER PER TYP. DETAIL "A" ON THIS SHEET

DECORATIVE STEEL BALL SPECS:  
 MFG: KING ARCHITECTURAL  
 3" DIAMETER 10 GAUGE BALL CATALOG #13-30HBL  
 1-1/2" DIAMETER 10 GAUGE BALL CATALOG #13-112

FINISH NOTE:

THE ITEMS SPECIFIED IN NOTES 1-5 SHALL BE POWDER COATED BLACK.

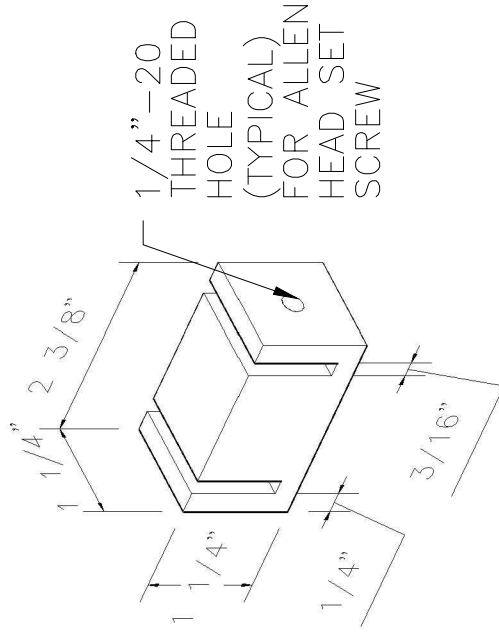
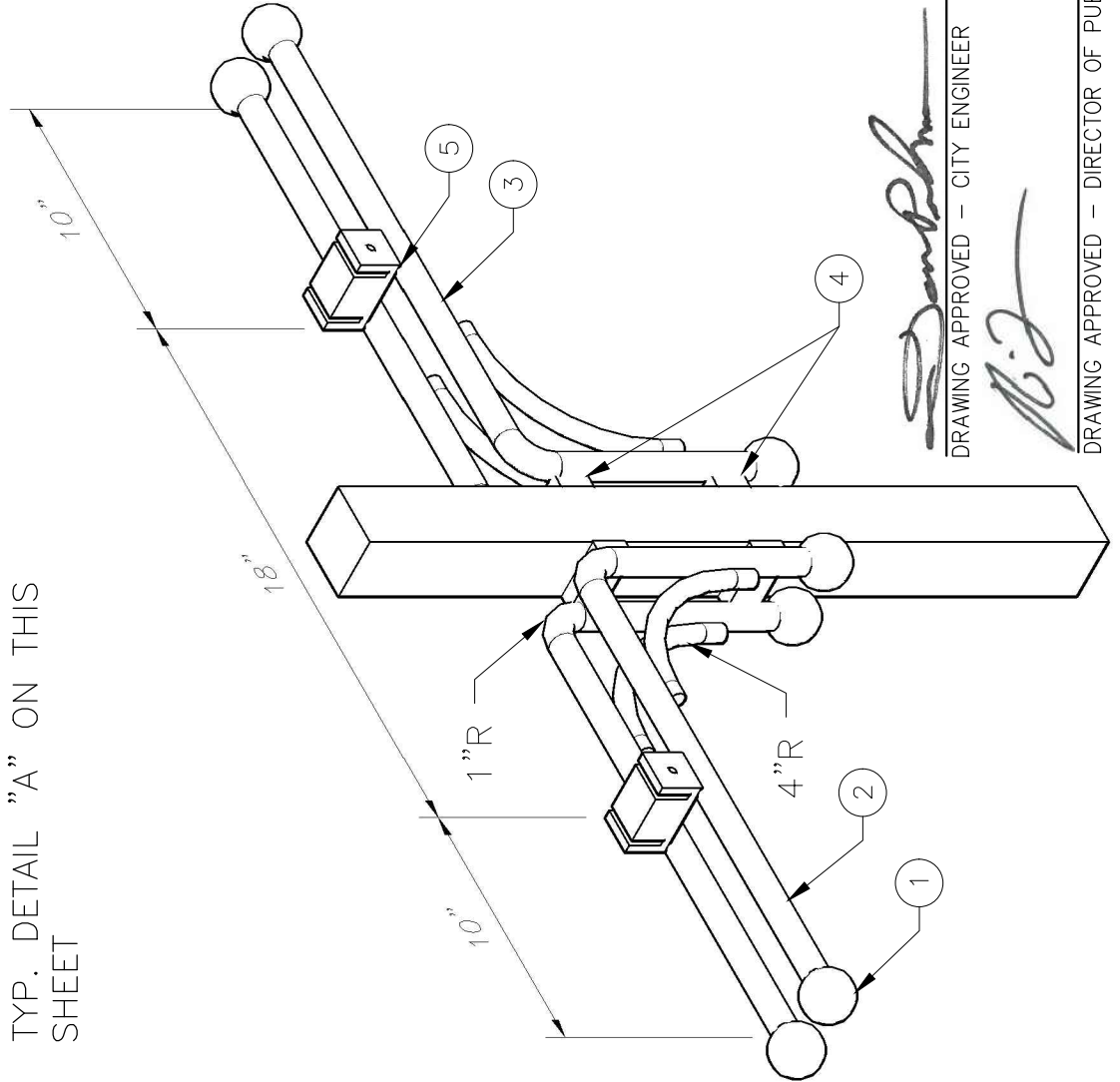

(A) SIGN BLADE HOLDER DETAIL (TYPICAL)

CITY OF ROCKLIN ENGINEERING DIVISION		DWG #
BOTTOM SIGN BRACKET CONFIGURATION		3-48
SCALE: NONE	DATE: 05/03/16	
DRAWN BY: J.PINKHAM		

*J. Pinkham*  
 DRAWING APPROVED - CITY ENGINEER

*J.P.*  
 DRAWING APPROVED - DIRECTOR OF PUBLIC WORKS

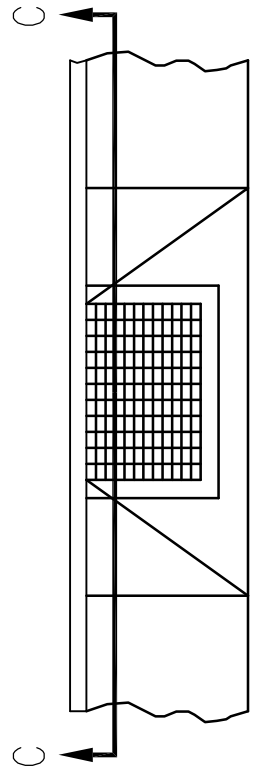
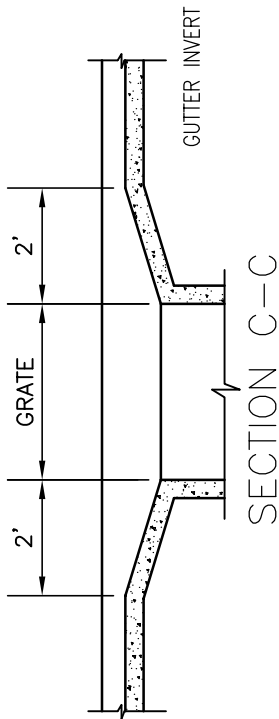

STANDARD DEPRESSION

NOTES:

1. GUTTER PAN IS STANDARD FOR ALL INLETS
2. SEE FRAME AND GRATE DETAIL, STANDARD DRAWING 4-4.
3. BOTTOM OF INLET SHALL BE PLACED PRIOR TO OR AT THE SAME TIME AS SIDE WALLS.
4. ALL INLETS OVER 48" IN OVERALL HEIGHT SHALL BE REINFORCED WITH #4 REBAR AT 8" O.C.
5. MAXIMUM DEPTH IS 6' OR PER CAL TRANS STANDARDS OR BY SPECIAL DESIGN.

NOTE: FOR TYPE 1, REFER TO 4-4

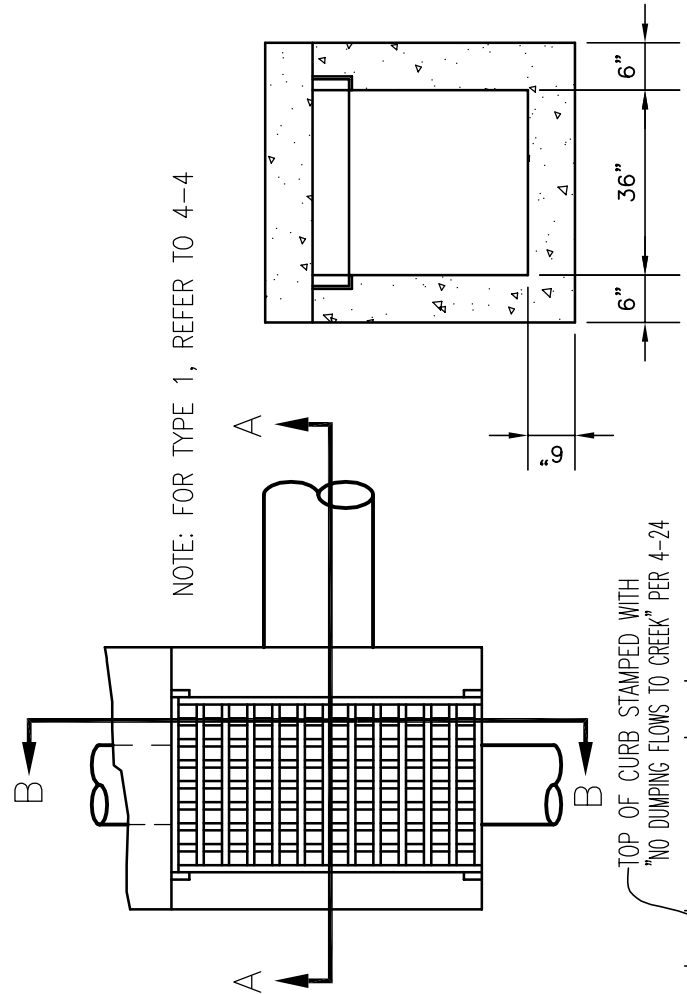

TOP OF CURB STAMPED WITH "NO DUMPING FLOWS TO CREEK" PER 4-24

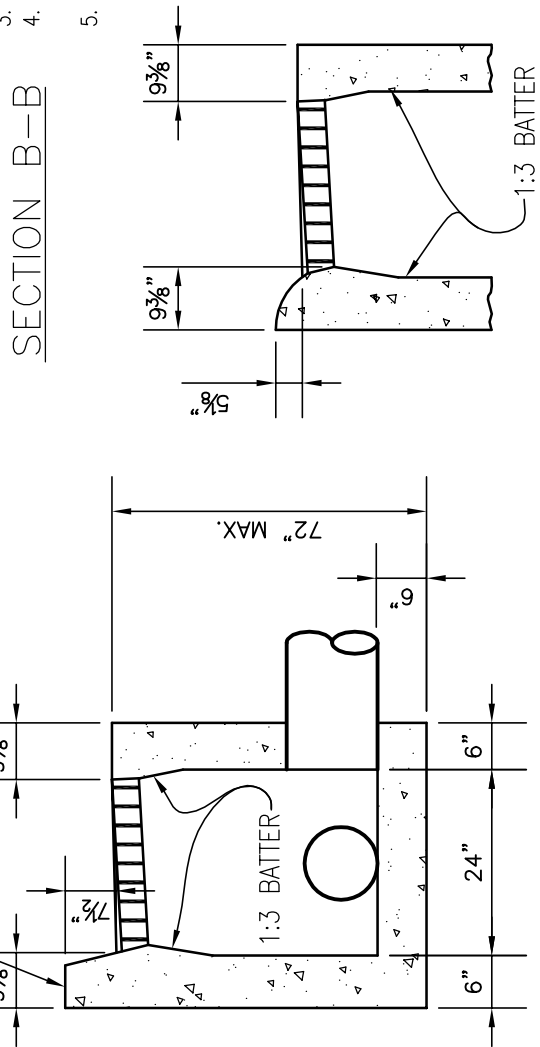

TYPE 2 CURB & GUTTER  
OR TYPE 5 CURB

TYPE 1 OR 1A CURB & GUTTER

DRAWING APPROVED - CITY ENGINEER

*[Signature]*

DRAWING APPROVED - DIRECTOR OF PUBLIC SERVICES

*[Signature]*

CITY OF ROCKLIN  
ENGINEERING DIVISION  
DROP INLET  
TYPE "A"

SCALE: NONE	DWG #
DATE: AUGUST 2015	4-1
DRAWN BY: J. PINKHAM	

- NOTES:**
1. SEE NOTES ON STANDARD DRAWING 4-1
  2. BOTTOM OF INLET SHALL BE PLACED PRIOR TO, OR AT THE SAME TIME AS THE SIDEWALKS
  3. FRAME AND GRATE SHALL CONFORM TO STANDARD DRAWING 4-4
  4. OPEN BACK HOOD SHALL BE CAST IRON AND H-20 RATED
  5. ALL INLETS OVER 48" IN OVERALL HEIGHT SHALL BE REINFORCED WITH #4 REBAR AT 8" O.C.
  6. MAXIMUM DEPTH IS 6" OR PER CALTRANS STANDARDS OR BY SPECIAL DESIGN.
  7. STANDARD DEPRESSION OF INLET IS 1-1/2"
  8. FRAME AND GRATE CONFORM TO 4-4
  9. ALL EXPOSED EDGES SHALL HAVE A 1/8" RADIUS AT CONCRETE HOOD

DRAWING APPROVED - CITY ENGINEER

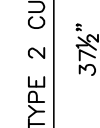

DRAWING APPROVED - DIRECTOR OF PUBLIC SERVICES

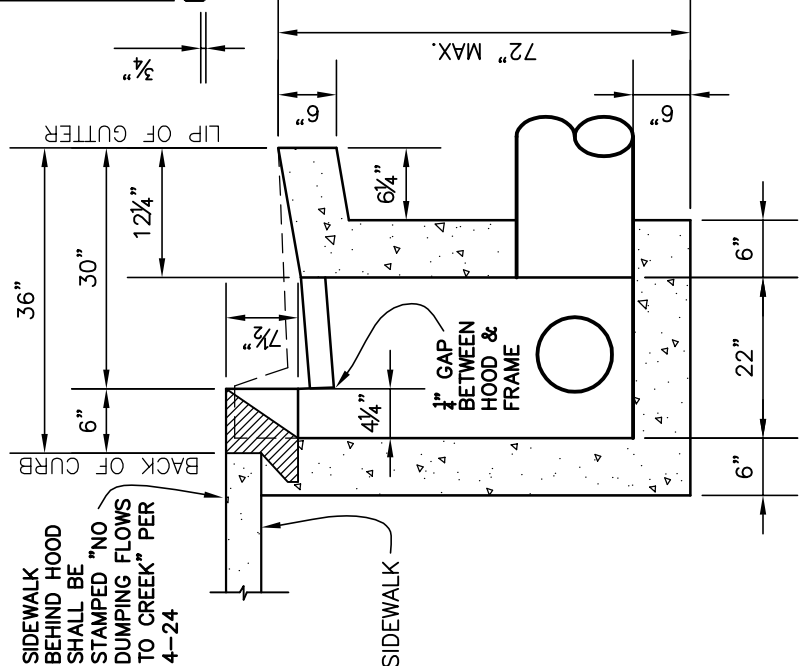
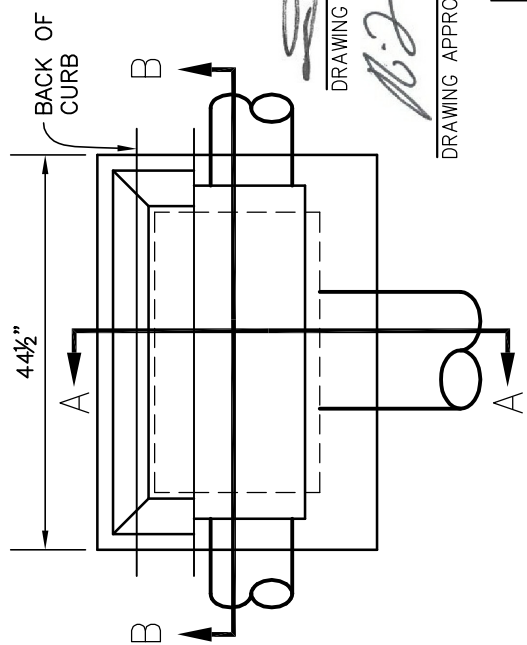
SECTION A-A  
TYPE 2 C & G

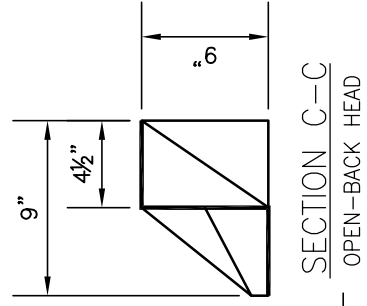

SECTION C-C  
OPEN-BACK HEAD

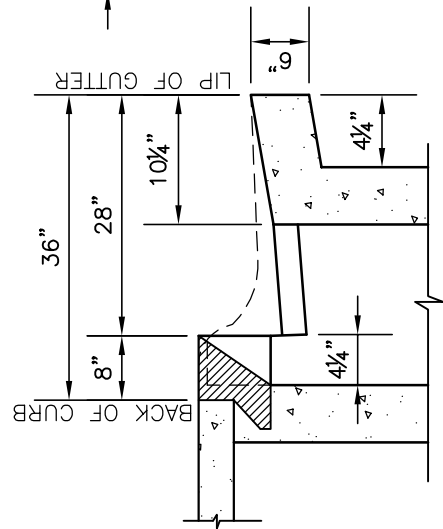

SECTION A-A  
TYPE 1 OR 1A C & G

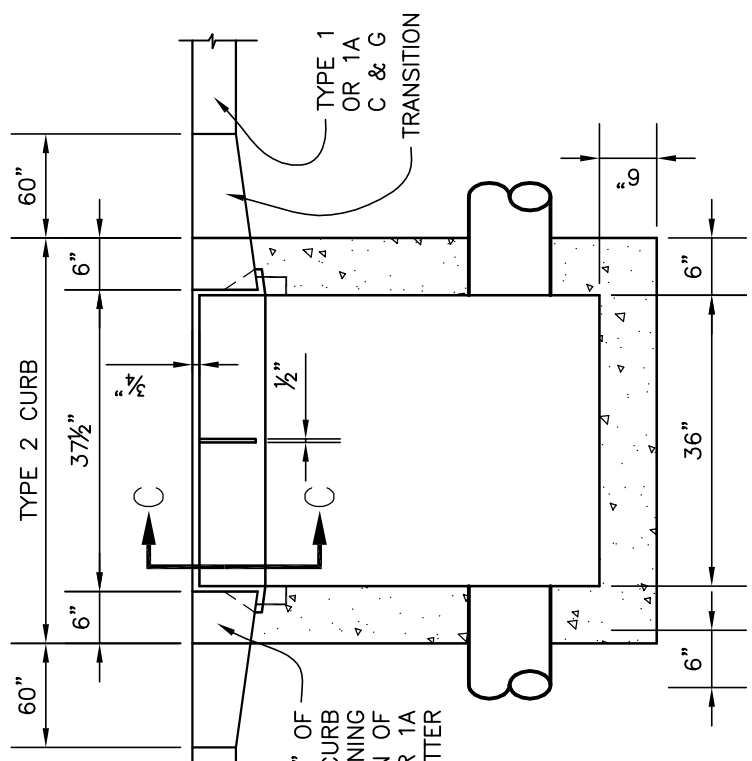

SECTION B-B

CITY OF ROCKKLIN  
ENGINEERING DIVISION  
DROP INLET  
TYPE "B"

SCALE: NONE	DWG #
DATE: AUGUST 2015	4-2
DRAWN BY: J. PINKHAM	





4 CORNERS

$\frac{3}{16}$ "

BOTH ENDS THESE BARS ONLY

$3\frac{1}{2}$ " X  $\frac{1}{4}$ " BARS TYP.

A

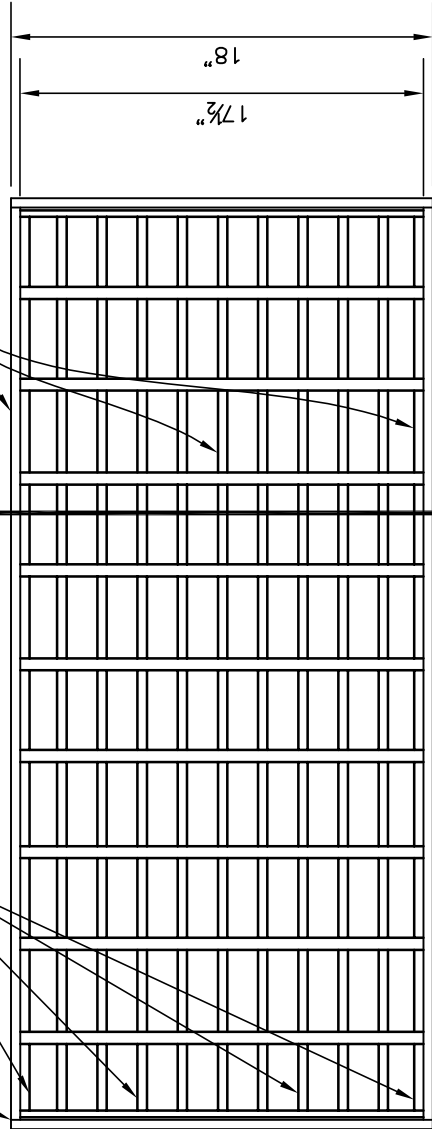

4" TYP.

39"

39 1/2"

41 1/2"

3" X 1/4" BAR

3" X 1/4" BAR

$\frac{5}{16}$ " DIA. TYP. HOT PRESS FIT

TYP.

4" X 3" X 1/2" ANGLE

4-1/2" DIA. ANCHORS

38 1/2"

1 1/2"

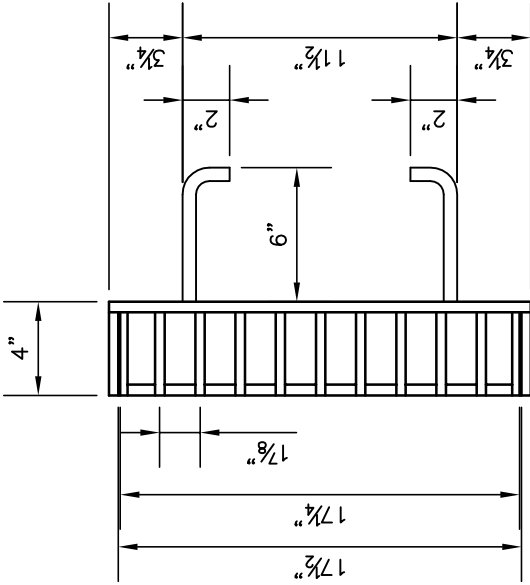

SECTION A-A

NOTE: AT THE CONTRACTOR'S OPTION, END SPACING OF 5/16" CROSS RODS MAY BE 2" INTERIOR SPACING SHALL REMAIN AT 4"

*[Signature]*

DRAWING APPROVED - CITY ENGINEER

*[Signature]*

DRAWING APPROVED - DIRECTOR OF PUBLIC SERVICES

CITY OF ROCKLIN  
ENGINEERING DIVISION

DROP INLET FRAME AND

GRATE FOR TYPE "A" & "B"

DROP INLETS

SCALE: NONE

DATE: AUGUST 2015

DRAWN BY: J. PINKHAM

DWG #

4-4

NOTE: GRATE MANUFACTURER SHALL BE APPROVED BY THE CITY ENGINEER. USA MADE ONLY.

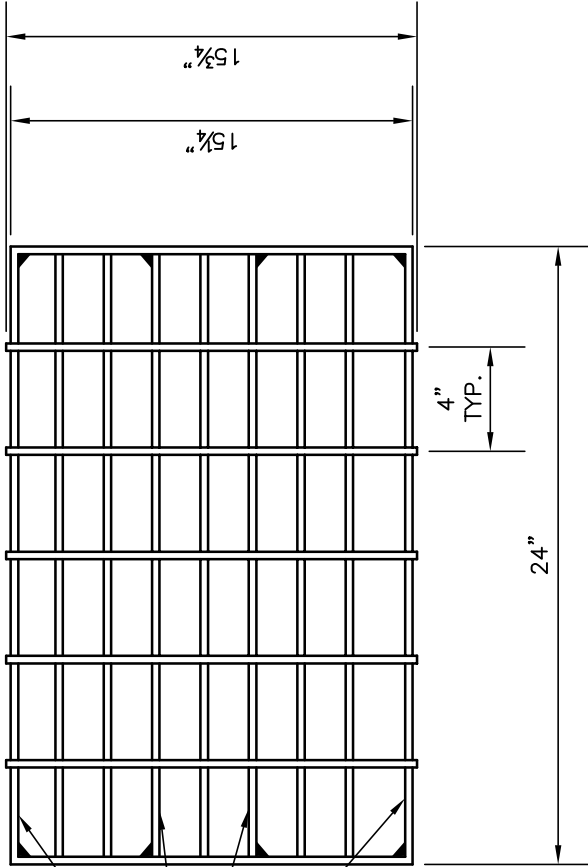

BOTH ENDS  
OF THESE  
BARS ONLY

3/16

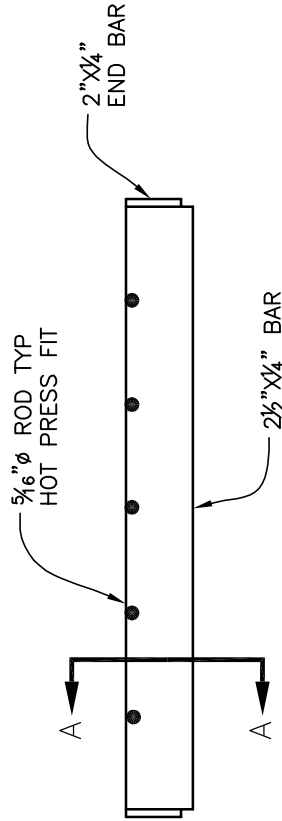

SECTION A-A

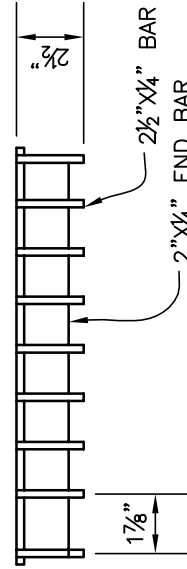

*[Signature]*  
DRAWING APPROVED - CITY ENGINEER

DRAWING APPROVED - DIRECTOR OF PUBLIC SERVICES

CITY OF ROCKLIN  
ENGINEERING DIVISION  
DROP INLET GRATE  
FOR TYPE "F"  
DROP INLETS

SCALE: NONE	DWG #
DATE: AUGUST 2015	4-5
DRAWN BY: J. PINKHAM	

- NOTES:
1. INSTALLED GRATED SHALL BE PERMANENTLY SECURED TO FRAME WITH 12" LENGTH OF GALVANIZED CHAIN.
  2. AT THE CONTRACTOR'S OPTION, END SPACING OF 5/16" CROSS RODS MAY BE 2". INTERIOR SPACING SHALL REMAIN AT 4".

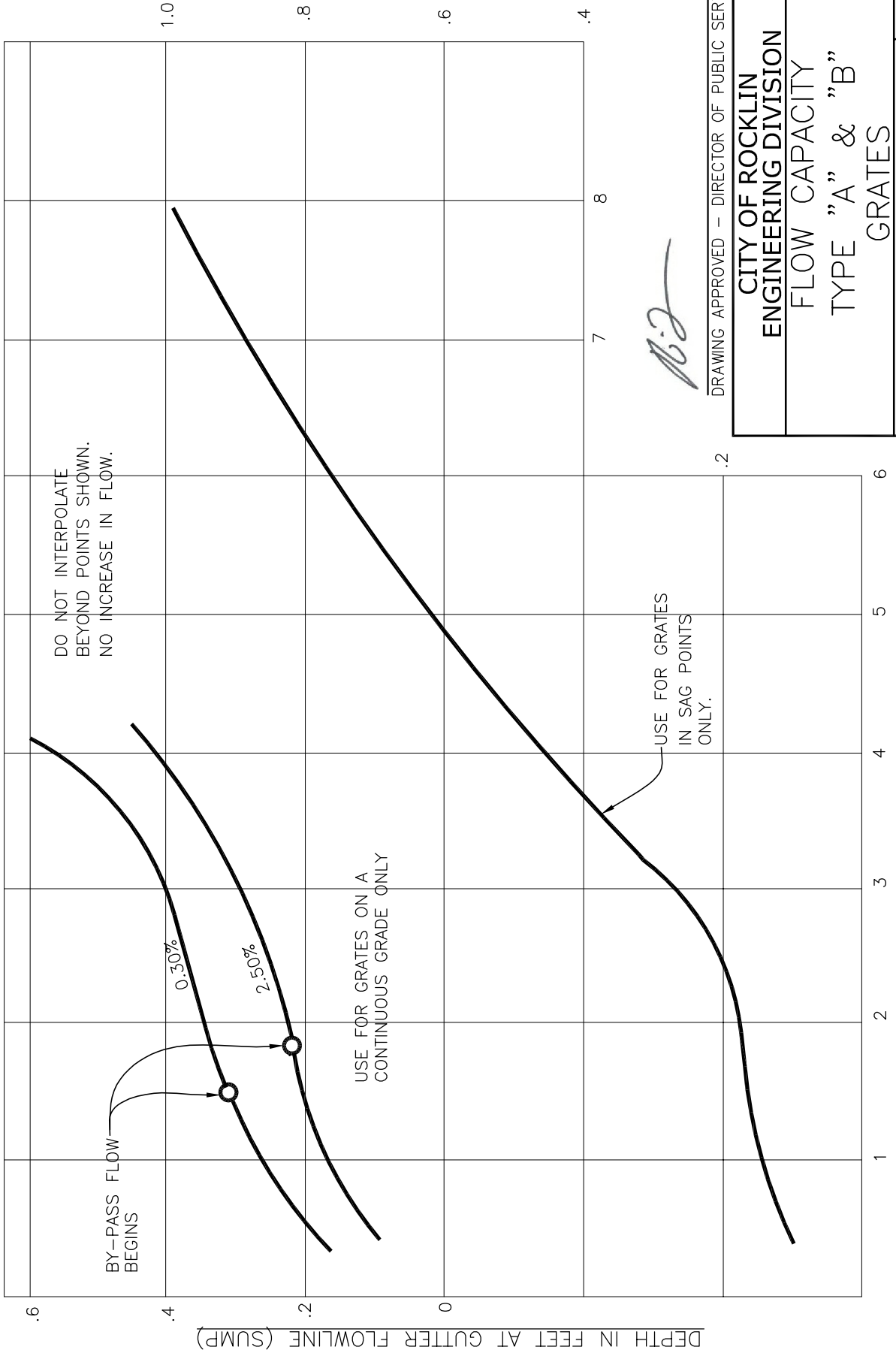

*[Handwritten signature]*

DRAWING APPROVED - DIRECTOR OF PUBLIC SERVICES

CITY OF ROCKLIN ENGINEERING DIVISION	
FLOW CAPACITY TYPE "A" & "B" GRATES	
SCALE: NONE	DWG #
DATE: AUGUST 2015	4-6
DRAWN BY: J. PINKHAM	

*[Handwritten signature]*  
DRAWING APPROVED - CITY ENGINEER

FLOW IN C. F. S.

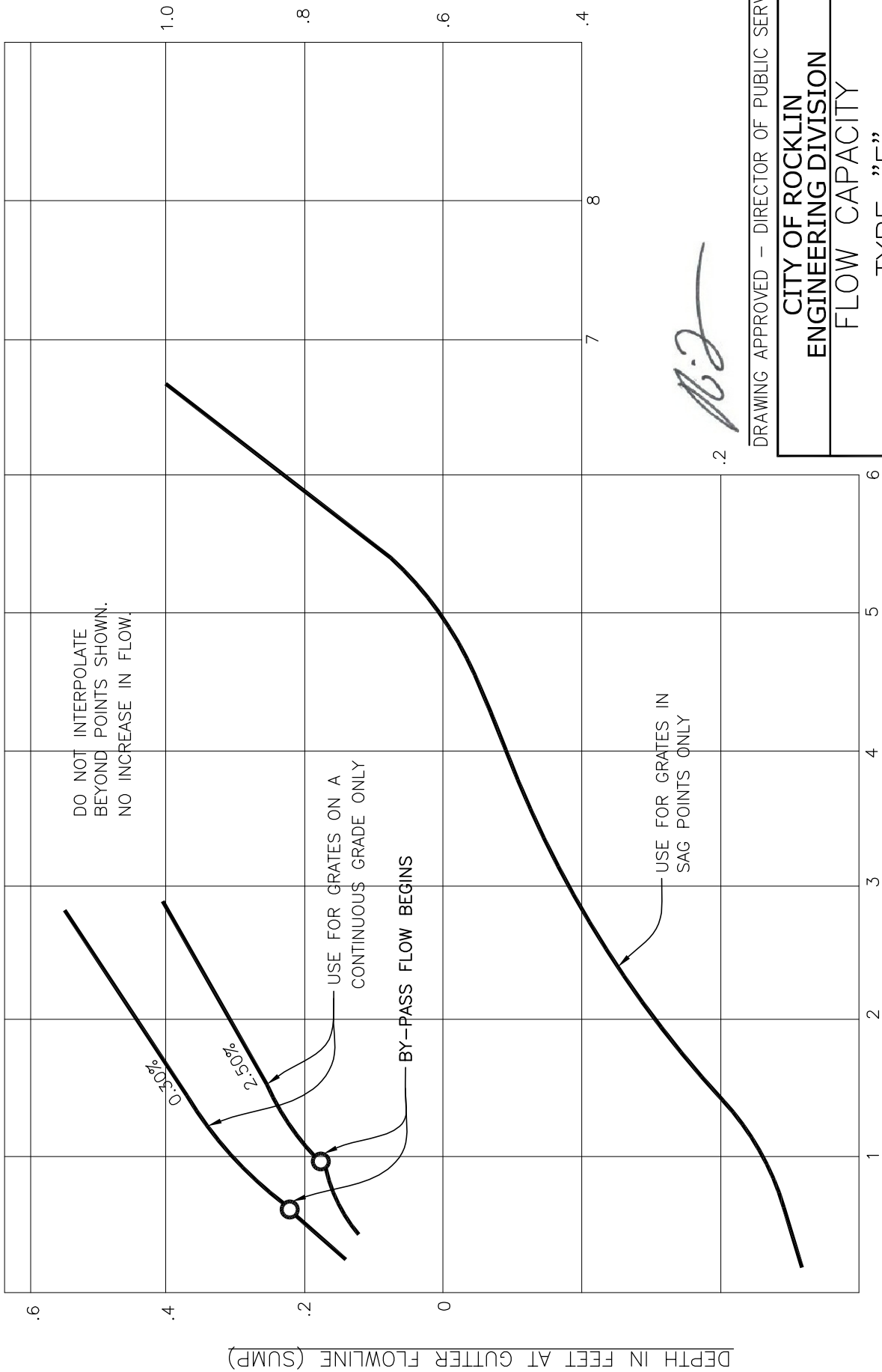

DO NOT INTERPOLATE  
BEYOND POINTS SHOWN.  
NO INCREASE IN FLOW.

0.30%

2.50%

USE FOR GRATES ON A  
CONTINUOUS GRADE ONLY

BY-PASS FLOW BEGINS

USE FOR GRATES IN  
SAG POINTS ONLY

*B.J.*

DEPTH IN FEET AT GUTTER FLOWLINE (SUMP)

FLOW IN C. F. S.

*[Signature]*

DRAWING APPROVED - CITY ENGINEER

DRAWING APPROVED - DIRECTOR OF PUBLIC SERVICES

CITY OF ROCKLIN  
ENGINEERING DIVISION  
FLOW CAPACITY

TYPE "F"  
GRATES

SCALE: NONE  
DATE: AUGUST 2015  
DRAWN BY: J. PINKHAM

DWG #  
4-7

**NOTES:**

1. ECCENTRIC CONES SHALL BE USED WHERE SPECIFIED ON THE PLANS
2. JOINTS MAY BE EITHER KEYED OR TONGUE AND GROOVE.

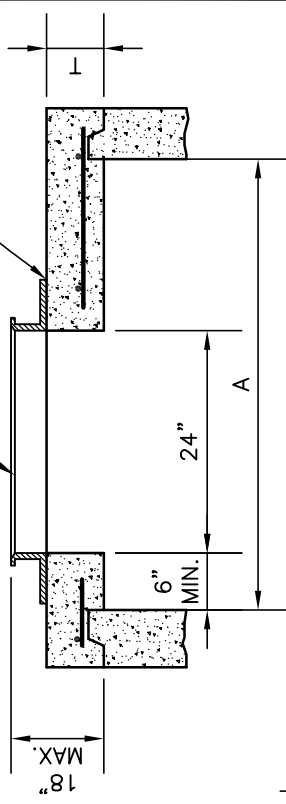

FLAT SLAB SHALL BE USED WHEN DEPTH DOES NOT PERMIT USE OF TAPER UNIT

TABLE OF DIMENSIONS

M.H.	A	B	T MIN.
48"	48"	18"	6"
60"	60"	30"	8"
72"	72"	42"	8"

DIMENSION "B" IS A MINIMUM DIMENSION AND MAY BE GREATER IF DEPTH PERMITS. RISER SECTIONS, CONES, AND ADJUSTING RINGS SHALL CONFORM TO ASTM DESIGNATION C-478

FRAME SHALL BE SECURED TO RISER OR FLAT SLAB TOP WITH CEMENT MORTAR

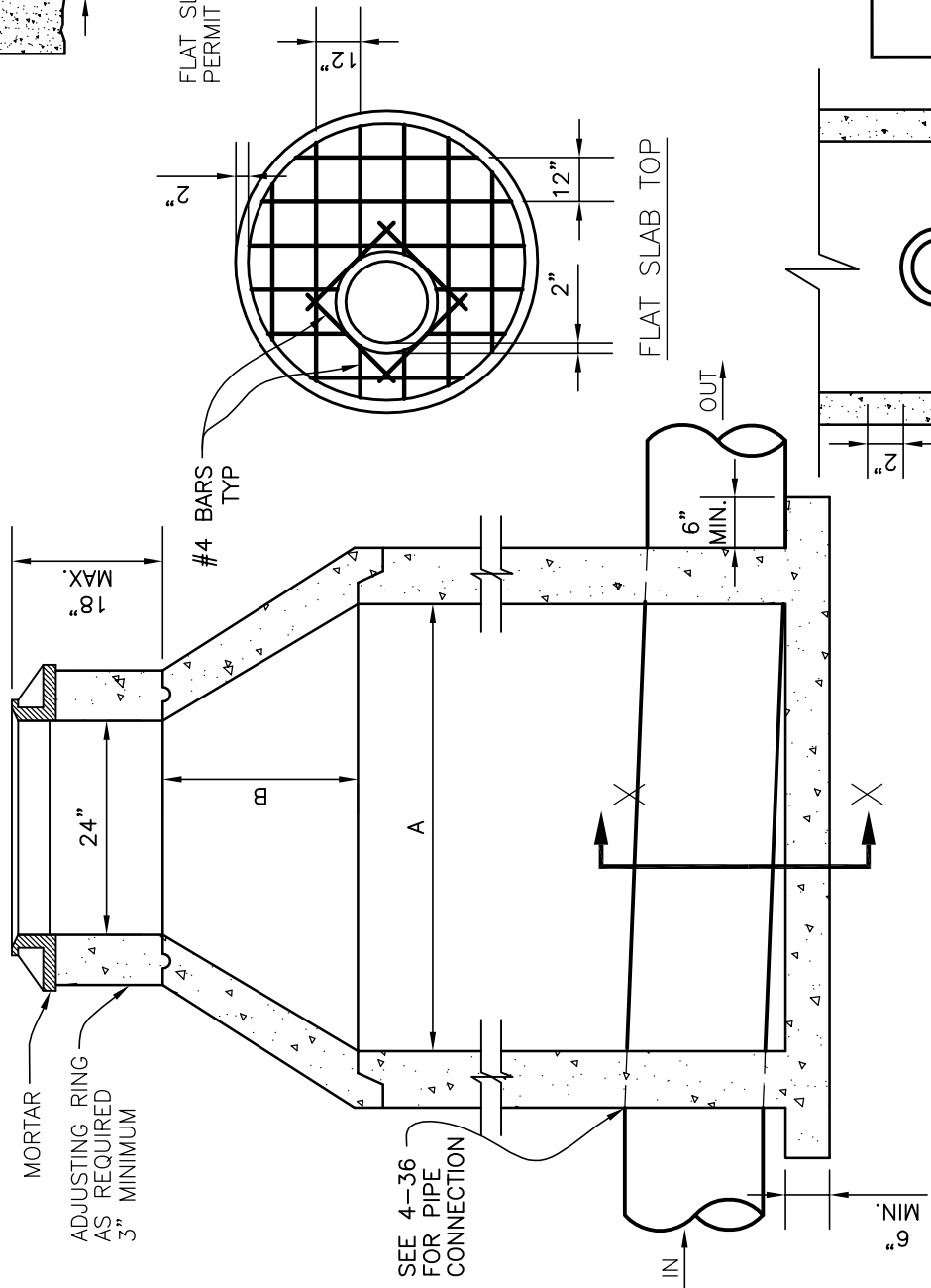

**CITY OF ROCKLIN  
ENGINEERING DIVISION**

STANDARD  
**PRECAST DRAINAGE  
MANHOLE**

**SCALE: NONE**  
**DATE: AUGUST 2015**  
**DRAWN BY: J. PINKHAM**

**DWG #**  
**4-8**

*[Handwritten Signature]*

DRAWING APPROVED - CITY ENGINEER

DRAWING APPROVED - DIRECTOR OF PUBLIC SERVICES

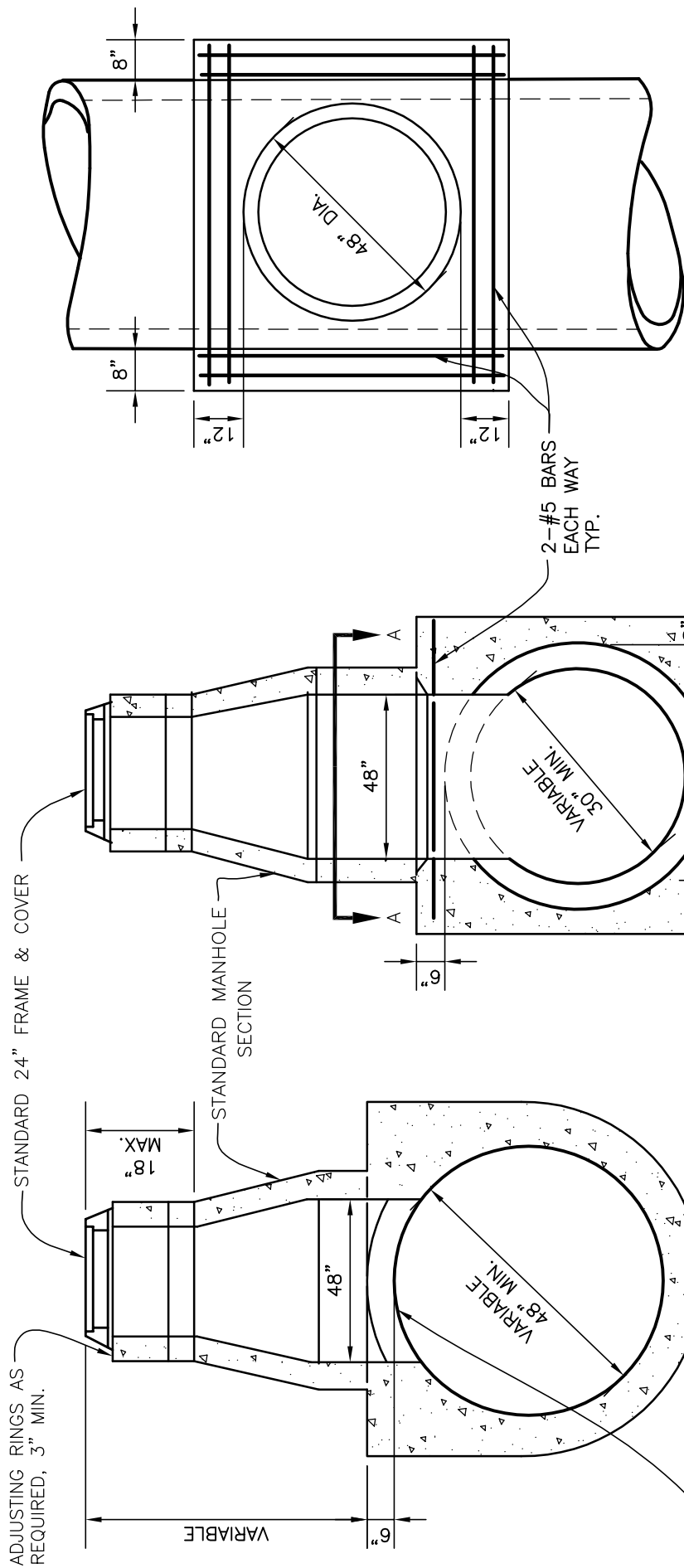

SECTION A-A

GENERAL NOTES:  
 1. ECCENTRIC CONES SHALL BE USED WHERE SPECIFIED ON THE PLANS.  
 2. JOINTS MAY BE EITHER KEYPED OR TONGUE AND GROOVED.

TYPE B

- 1. ALL PIPE OTHER THAN CAST-IN-PLACE PIPE
- 2. CAST-IN-PLACE PIPE LESS THAN 48" DIA.

TYPE A

CAST-IN-PLACE PIPE ONLY  
 NOTE:  
 REMOVE CONCRETE IN MANHOLE OPENING AND CONSTRUCTION RISER BASE WHILE CONCRETE IS STILL FRESH  
 PLACE RISER SECTION AFTER CONCRETE HAS SET.

CITY OF ROCKLIN ENGINEERING DIVISION		DWG #
TYPE "A" & "B"		4-9
SADDLE MANHOLE		
SCALE: NONE	DATE: AUGUST 2015	
DRAWN BY: J. PINKHAM		

*[Signature]*  
 DRAWING APPROVED - CITY ENGINEER

*[Signature]*  
 DRAWING APPROVED - DIRECTOR OF PUBLIC SERVICES







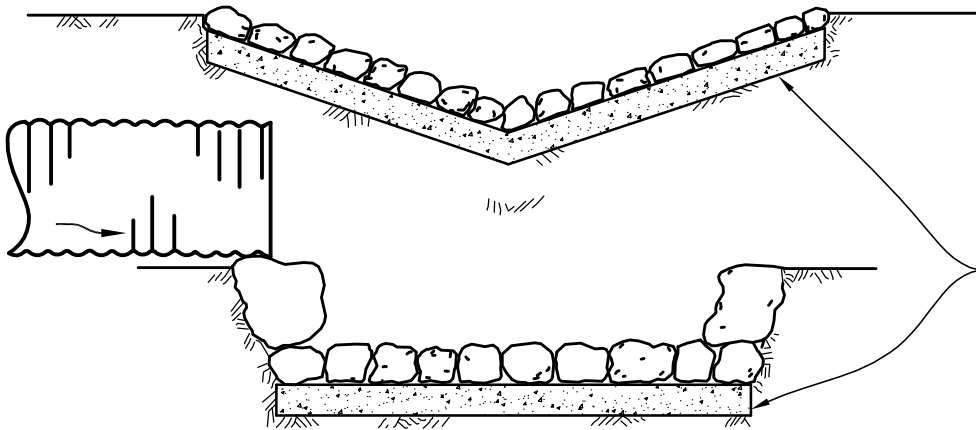

BOTH COBBLE AND QUARRY ROCK SHALL BE CONCRETED IN PLACE WITH A MINIMUM OF 6" BED OF CONCRETE IF APPROVED BY THE ARMY CORP. 404 PERMIT.

STREAM BANK SLOPE PROTECTION

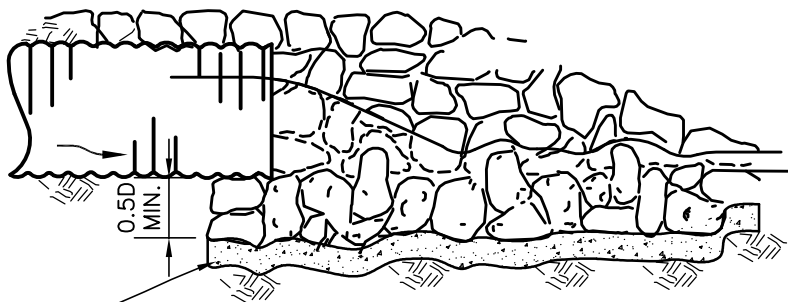

SECTION A-A

BOTH COBBLE AND QUARRY ROCK SHALL BE CONCRETED IN PLACE WITH A MINIMUM OF 6" BED OF CONCRETE IF APPROVED BY THE ARMY CORPS 404 PERMIT

0.5D MIN.

3.5D MIN.

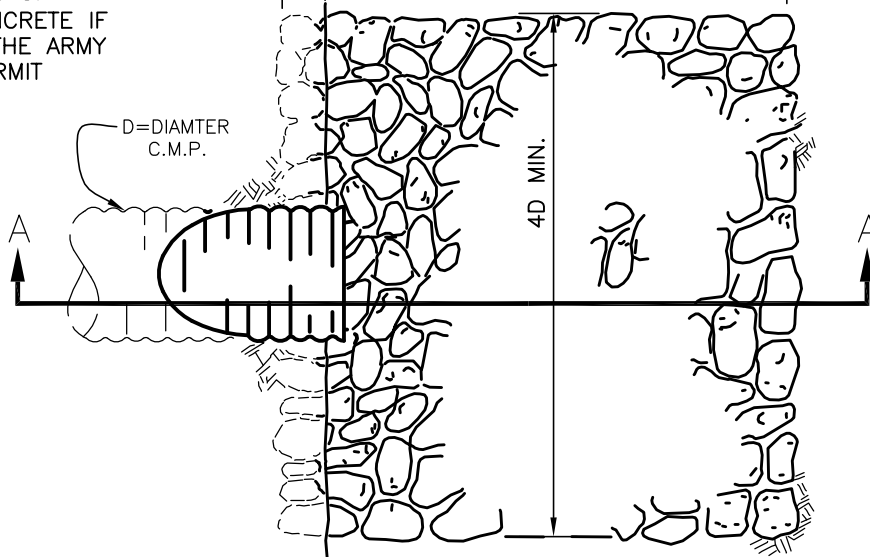

CULVERT OUTFALL

NOTE:

STONE LINING SHALL BE GROUTED COBBLES CONFORMING TO THE REQUIREMENTS OF THE STANDARD CONSTRUCTION SPECIFICATIONS OR QUARRY ROCK CONFORMING TO THE REQUIREMENTS OF THE STANDARD CONSTRUCTION SPECIFICATIONS SS-15 & SS-16 AND CALTRANS SECTION 72.

*[Signature]*

DRAWING APPROVED - CITY ENGINEER

*[Signature]*

DRAWING APPROVED - DIRECTOR OF PUBLIC SERVICES

CITY OF ROCKLIN ENGINEERING DIVISION	
CULVERT OUTFALL AND STREAM BANK SLOPE PROTECTION	
SCALE: NONE	DWG #
DATE: DECEMBER 2015	4-12
DRAWN BY: J. PINKHAM	



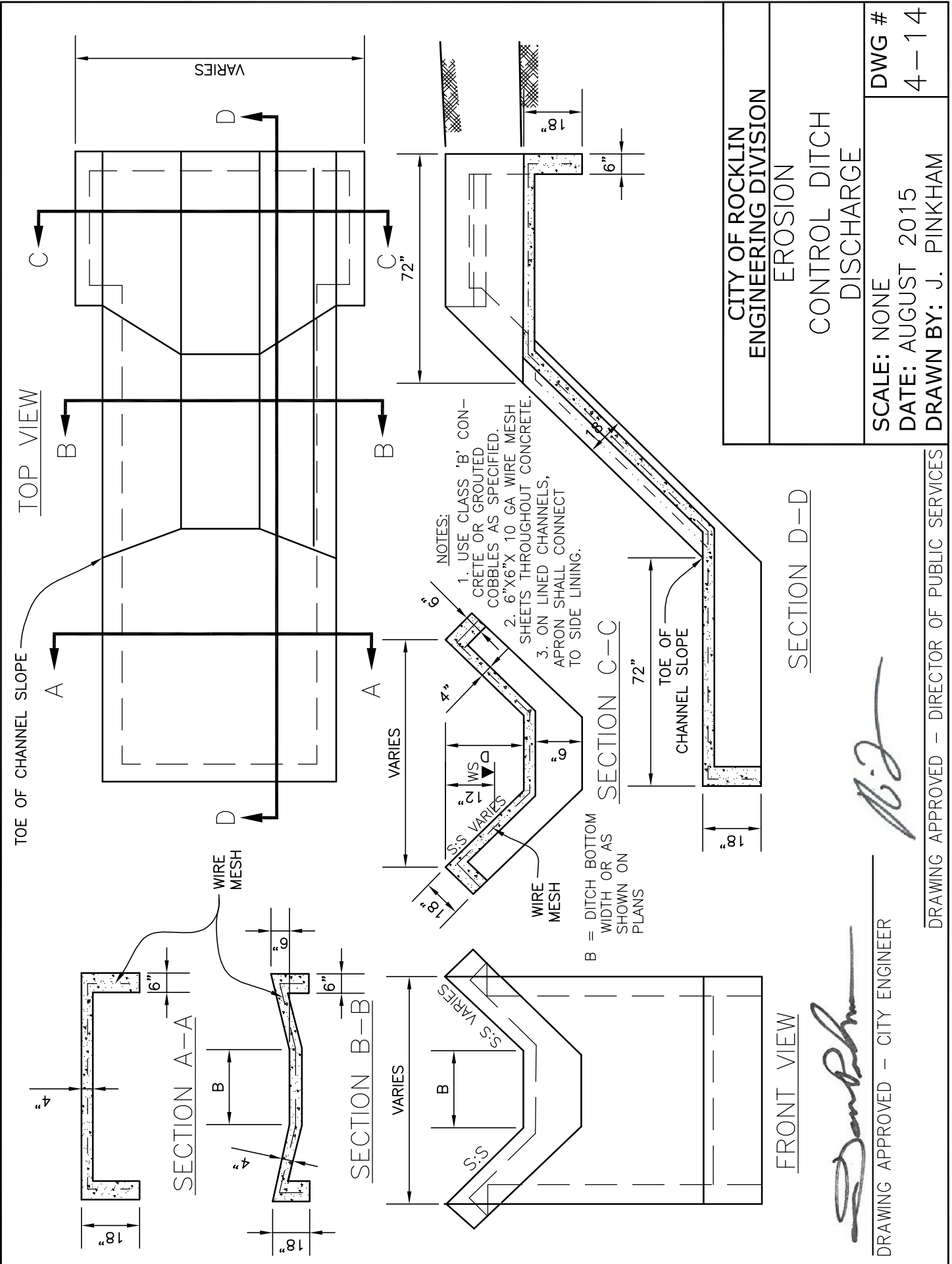

DIMENSIONS & REINFORCING

D	W	B	L	T	ALL REINFORCING
33"	3'-5"	5'-3"	4'-0"	6"	# 5 @ 12"
36"	3'-8"	5'-8"	4'-2"	6"	# 5 @ 12"
42"	4'-4"	6'-4"	4'-8"	6"	# 5 @ 12"
48"	4'-10"	7'-2"	5'-2"	8"	# 6 @ 12"
54"	5'-4"	8'-0"	6'-0"	8"	# 6 @ 12"
60"	6'-0"	8'-10"	6'-6"	8"	# 6 @ 12"

NOTES:

1. "B" MAY BE REDUCED IF REQUIRED BY CHANNEL DIMENSIONS.
2. REINFORCING BAR SPACING SHOWN IS MAXIMUM SPACING.
3. USE CLASS 'B' CONCRETE.

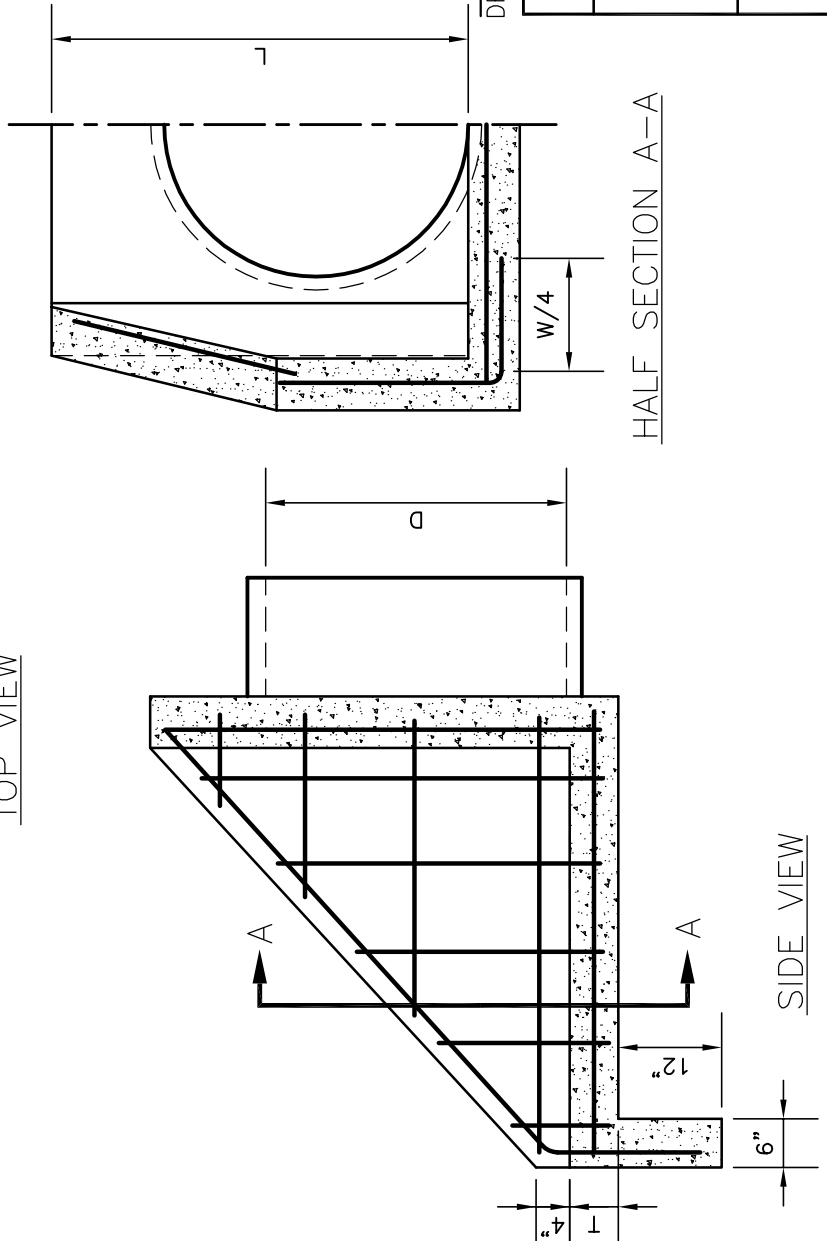
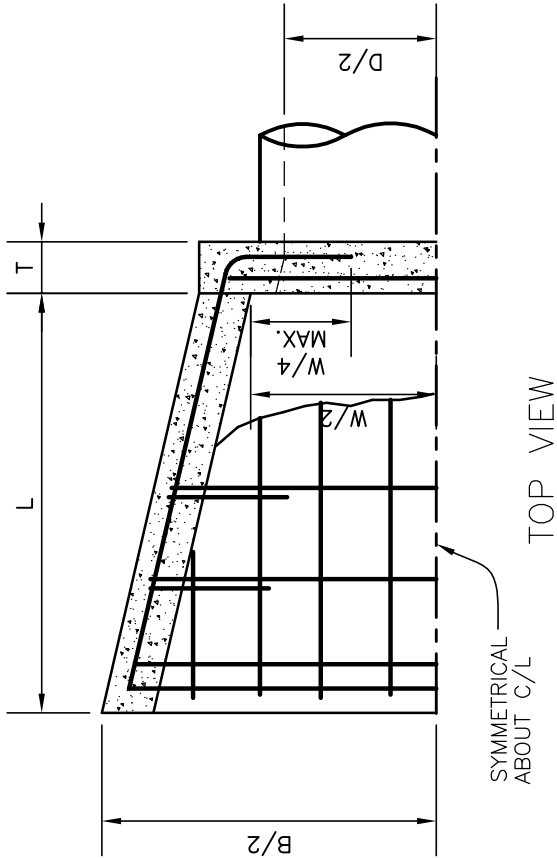

DRAWING APPROVED - DIRECTOR OF PUBLIC SERVICES

CITY OF ROCKLIN  
ENGINEERING DIVISION

PIPE  
INLET  
STRUCTURE

SCALE: NONE  
DATE: AUGUST 2015  
DRAWN BY: J. PINKHAM

DWG #  
4-15

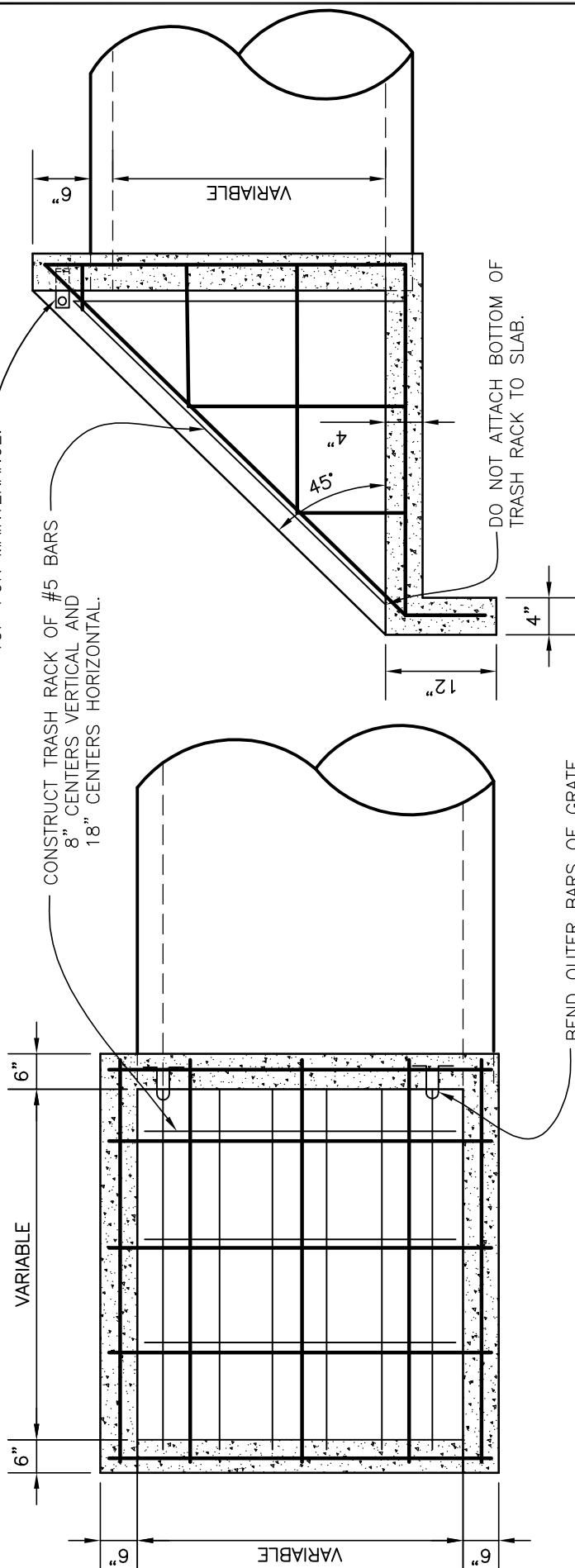

RACK NEEDS TO HINGE ON TOP FOR MAINTENANCE.

CONSTRUCT TRASH RACK OF #5 BARS 8" CENTERS VERTICAL AND 18" CENTERS HORIZONTAL.

DO NOT ATTACH BOTTOM OF TRASH RACK TO SLAB.

TOP VIEW

SIDE VIEW

NOTE:

ALL REINFORCING TO BE #4 @ 12" USE CLASS 'B' CONCRETE.

\* PIPE MUST BE RCP TO FIRST MANHOLE

*[Signature]*

DRAWING APPROVED – CITY ENGINEER

*[Signature]*

DRAWING APPROVED – DIRECTOR OF PUBLIC SERVICES

CITY OF ROCKLIN  
ENGINEERING DIVISION

PIPE INLET STRUCTURE  
AND TRASH RACK –  
30" PIPE AND SMALLER

SCALE: NONE

DATE: AUGUST 2015

DRAWN BY: J. PINKHAM

DWG #

4-16







4" x 3" x 1/4" STEEL TUBE  
 1/8" CHAMFER BOTH ENDS

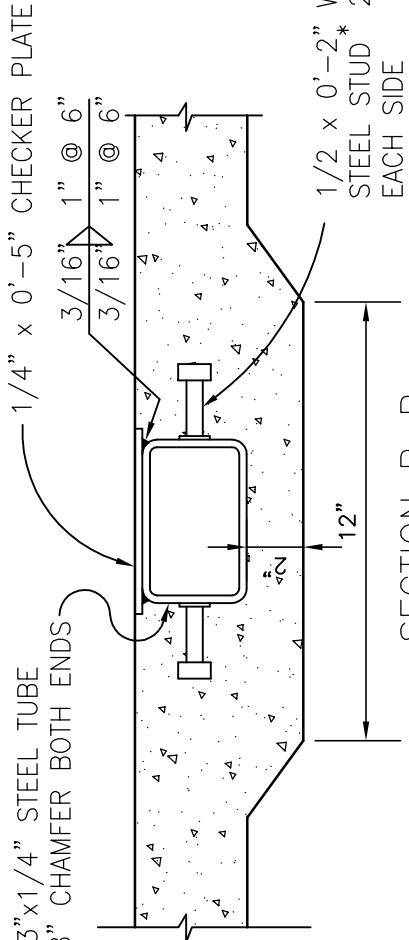
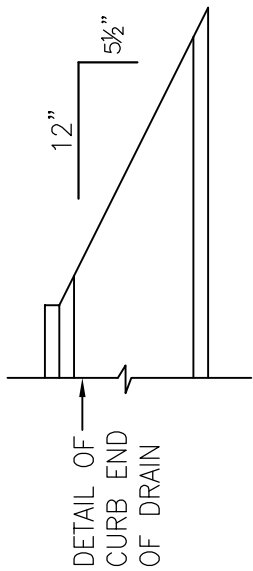

SECTION B-B

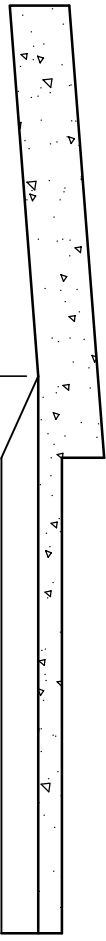

\* #3 REBAR MAY BE SUBSTITUTED FOR 1/2" x 0'-2" STEEL STUDS

SECTION A-A  
 (FOR TYPE 1 OR 1A CURB)

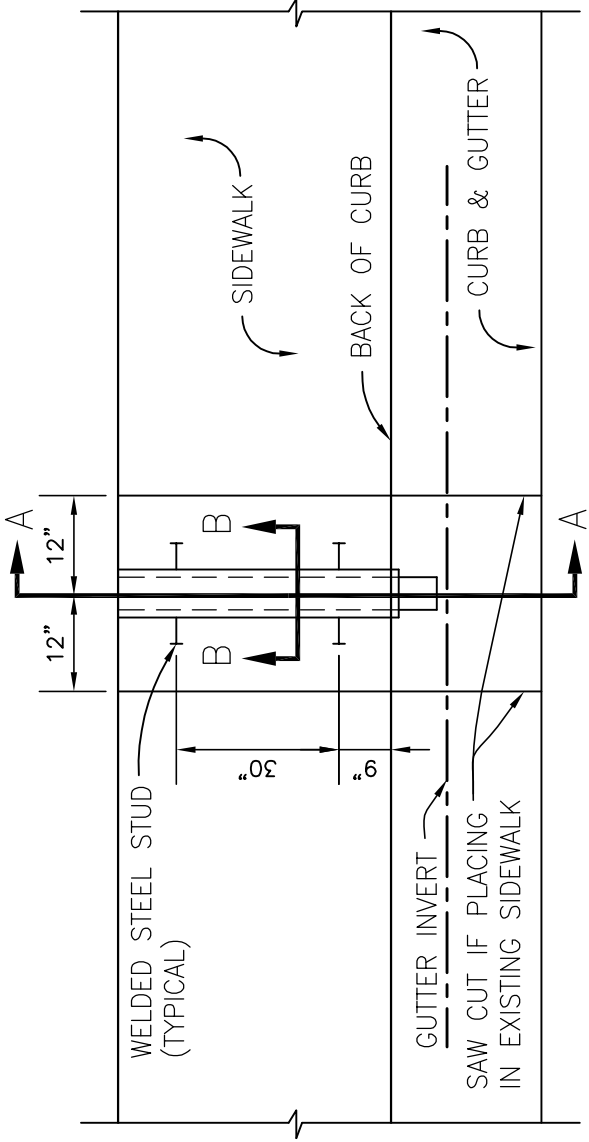

NOTE:

GALVANIZE AFTER FABRICATION

*[Signature]*  
 DRAWING APPROVED - CITY ENGINEER

*[Signature]*

DRAWING APPROVED - DIRECTOR OF PUBLIC SERVICES

CITY OF ROCKLIN ENGINEERING DIVISION	
UNDER SIDEWALK DRAIN	
SCALE: NONE	DWG # 4-19
DATE: MAY 2016	
DRAWN BY: J. PINKHAM	

PLAN VIEW OF CURB, GUTTER & SIDEWALK

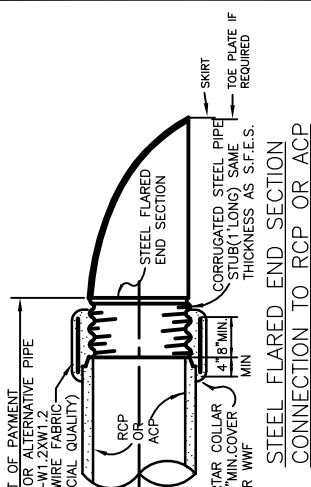

- NOTES**
1. ALL 3PC BODIES TO HAVE 0.109" THICK SIDES AND 0.138" THICK CENTER PANELS WIDTH OF CENTER PANELS TO BE GREATER THAN 20% OF THE PIPE PERIPHERY. MULTIPLE PANEL BODIES TO HAVE LAP SEAMS WHICH ARE TO BE TIGHTLY JOINED BY RIVETS OR BOLTS.
  2. REINFORCED EDGES TO BE SUPPLEMENTED WITH STIFFENER ANGLES FOR THE 60" THRU 84" ROUND, 77" X 52" AND 83" X 57" PIPE-ARCH SIZES. THE ANGLES WILL BE 2" X 2" X 1/4" FOR THE 60" THRU 72" ROUND, 77" X 52" AND 83" X 57" PIPE-ARCH SIZES AND 2" X 2" X 1/4" FOR THE 60" THRU 72" ROUND, 77" X 52" AND 83" X 57" PIPE-ARCH SIZES. THE ANGLES TO BE ATTACHED BY 3/8" NUTS AND BOLTS.
  3. ANGLE REINFORCEMENT WILL BE PLACED UNDER THE CENTER PANEL SEAMS ON THE 77" X 52" AND 83" X 57" PIPE-ARCH SIZES.
  4. TOE PLATE TO BE AVAILABLE AS AN ACCESSORY.
  5. END OF PIPE TO BE FINISHED WITH ANNUAL CORRUGATIONS TO CONFORM TO THE STANDARD SPECIFICATIONS FROM THE CONNECTION. OTHER DESIGNS MAY BE USED WITH APPROVAL OF THE ENGINEER.
  6. CONTRACTOR HAS THE OPTION OF USING EITHER TYPE A OR B PRECAST CONCRETE FLARED END SECTION.
  7. FOR 12" THRU 24" HELICAL END SECTION CONNECTION, A UNIVERSAL COUPLING BAND ATTACHED TO THE METAL END SECTION BY RIVETS, BOLTS OR ONE INCH LONG SHOP TACK WELDS SPACED AT SAME INTERVALS MAY BE USED IN PLACE OF THE 12" STUB. SEE STANDARD PLAN 897-C.

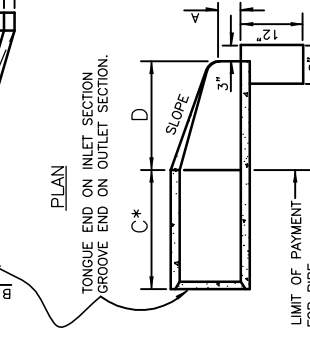
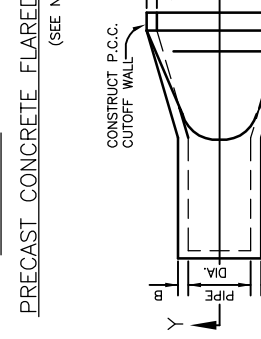
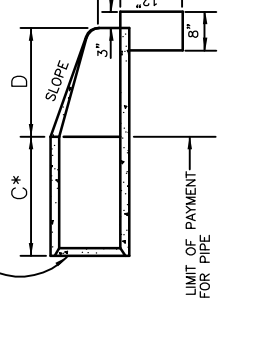
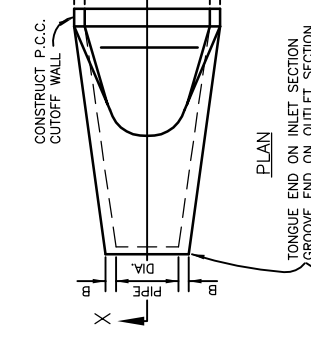
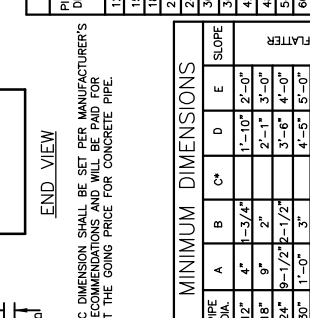
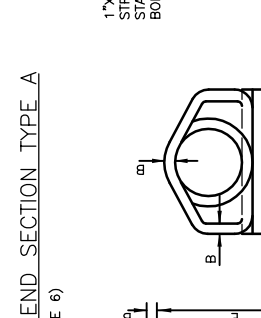
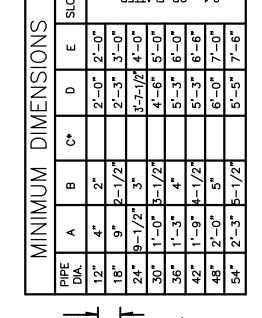
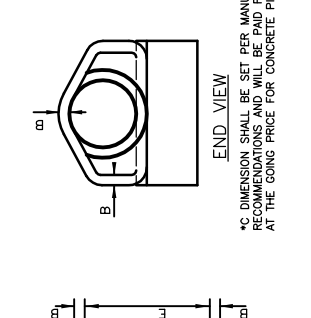
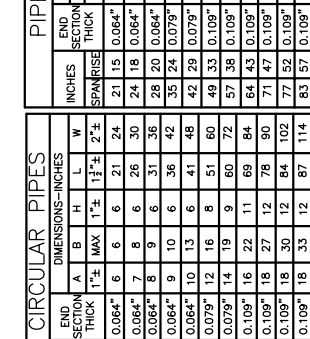
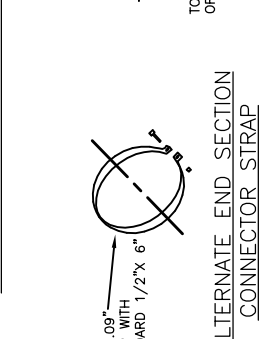
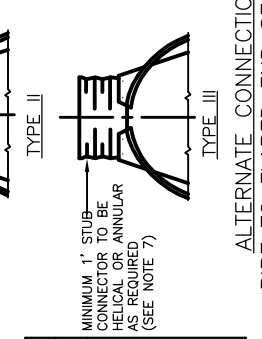
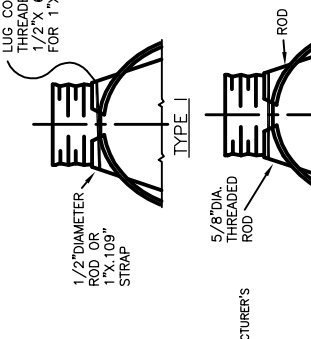
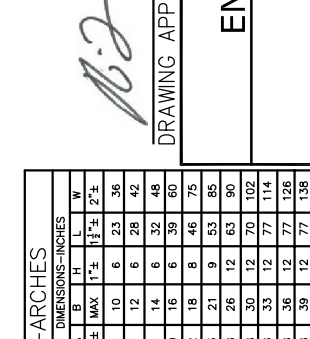
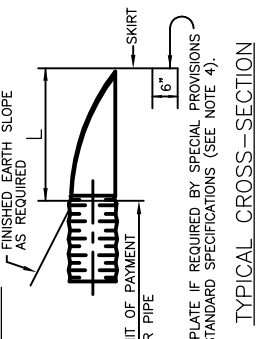
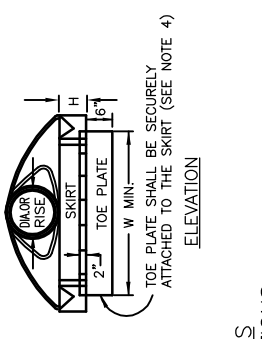
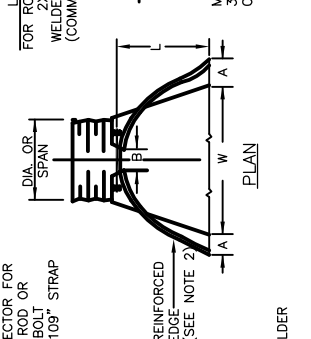

DRAWING APPROVED - DIRECTOR OF PUBLIC SERVICES

**CITY OF ROCKLIN**  
ENGINEERING DIVISION

**FLARED END SECTION**

SCALE: NONE  
DATE: AUGUST 2015  
DRAWN BY: J. PINKHAM

DWG # 4-20

**CIRCULAR PIPES**

PIPE DIA.	DIMENSIONS-INCHES		
	A	B	H
12"	1 1/2"	1 1/2"	2 1/2"
15"	2"	2"	3"
18"	2 1/2"	2 1/2"	3 1/2"
21"	3"	3"	4"
24"	3 1/2"	3 1/2"	4 1/2"
30"	4 1/2"	4 1/2"	5 1/2"
36"	5 1/2"	5 1/2"	6 1/2"
42"	6 1/2"	6 1/2"	7 1/2"
48"	7 1/2"	7 1/2"	8 1/2"
54"	8 1/2"	8 1/2"	9 1/2"

**PIPE-ARCHES**

PIPE DIA.	DIMENSIONS-INCHES		
	A	B	H
12"	1 1/2"	1 1/2"	2 1/2"
15"	2"	2"	3"
18"	2 1/2"	2 1/2"	3 1/2"
21"	3"	3"	4"
24"	3 1/2"	3 1/2"	4 1/2"
30"	4 1/2"	4 1/2"	5 1/2"
36"	5 1/2"	5 1/2"	6 1/2"
42"	6 1/2"	6 1/2"	7 1/2"
48"	7 1/2"	7 1/2"	8 1/2"
54"	8 1/2"	8 1/2"	9 1/2"

FLARED END SECTIONS FOR C.M.P. CULVERTS

DRAWING APPROVED - CITY ENGINEER

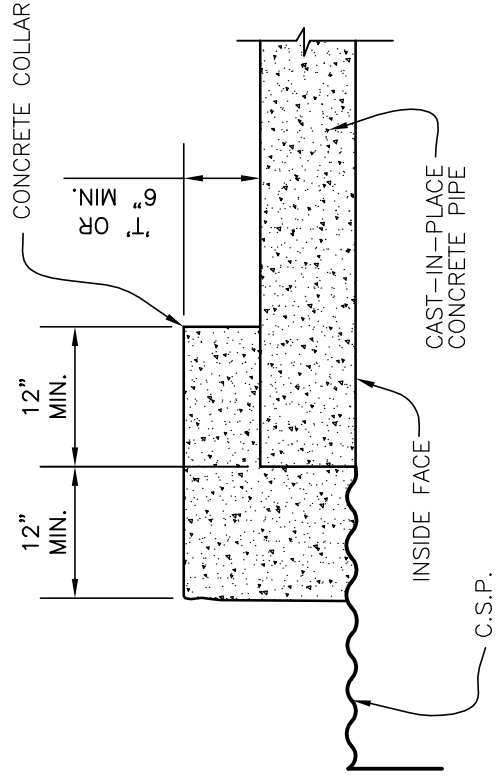

CONCRETE PIPE TO CONCRETE PIPE  
WITHOUT STANDARD JOINT

CAST-IN-PLACE OR PRECAST CONCRETE  
PIPE TO C.S.P.

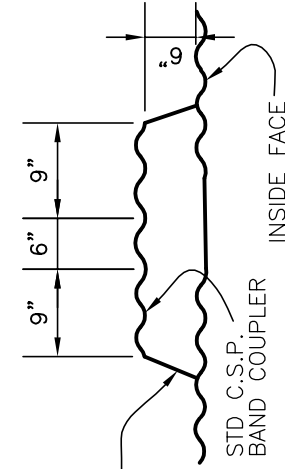

PIPES OF DISSIMILAR METALS

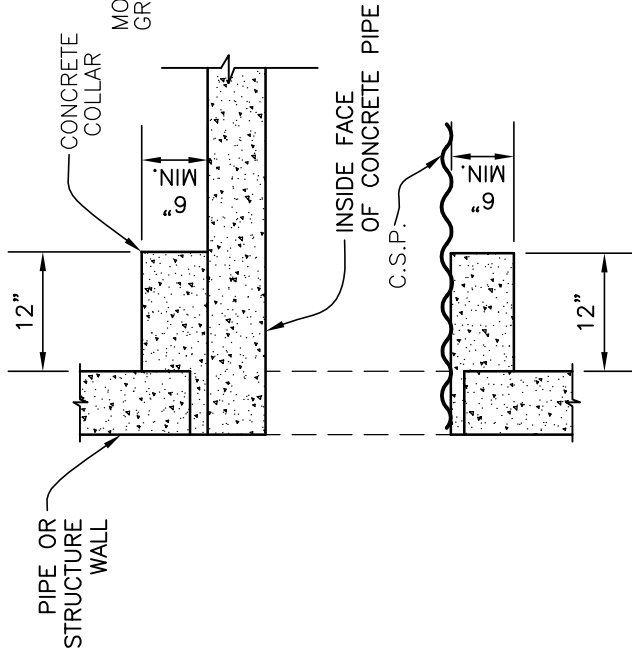

CONCRETE PIPE OR C.S.P.  
INTO EXISTING STRUCTURE

NOTE:  
C.A.P. MAY BE USED OUTSIDE OF  
CITY R/W. FOR COVER REQUIREMENTS,  
SEE STANDARD DRAWING 5-2.

*[Signature]*

DRAWING APPROVED – DIRECTOR OF PUBLIC SERVICES

**CITY OF ROCKLIN  
ENGINEERING DIVISION**

**CONCRETE  
PIPE  
CONNECTIONS**

*[Signature]*  
DRAWING APPROVED – CITY ENGINEER

<b>SCALE:</b> NONE	<b>DWG #</b> 4-21
<b>DATE:</b> DECEMBER 2015	
<b>DRAWN BY:</b> J. PINKHAM	

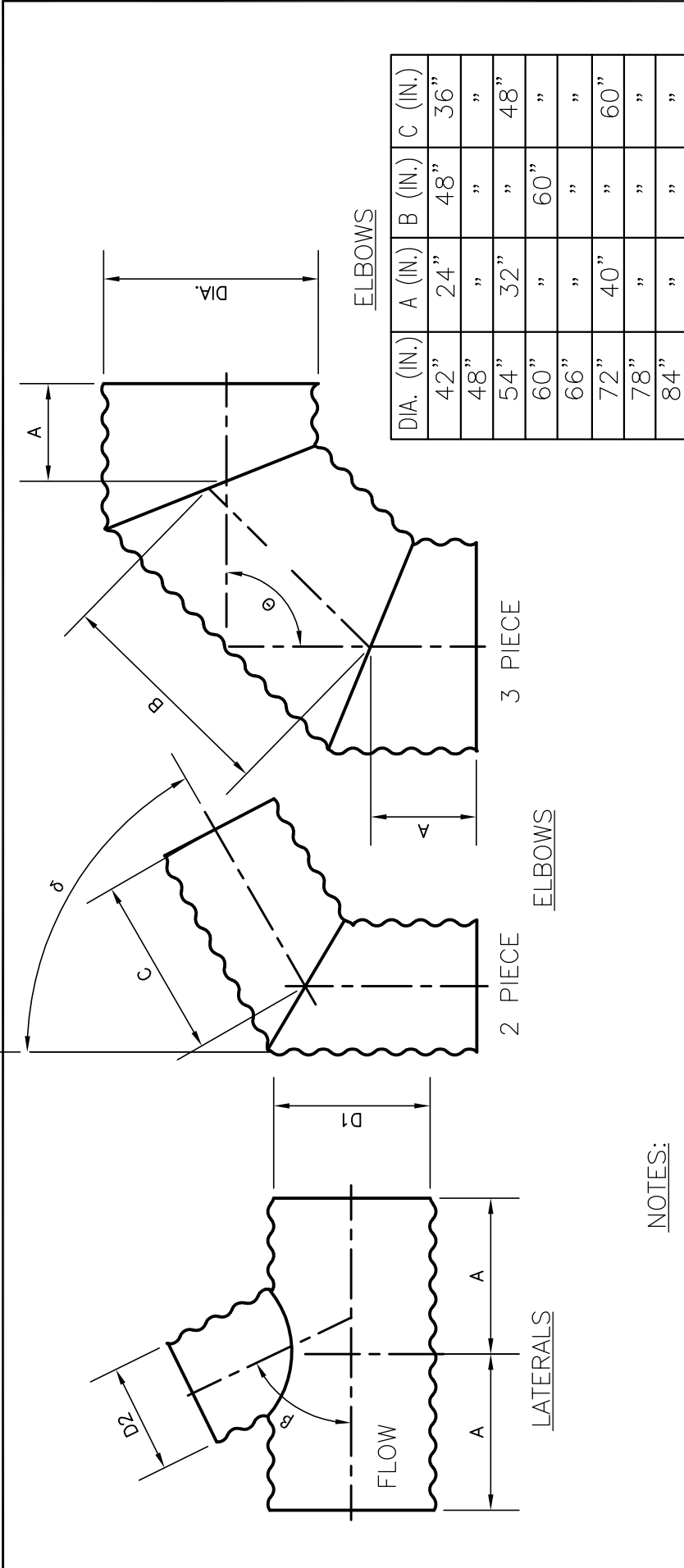

**NOTES:**

1. LATERALS MAY BE FABRICATED TO MATCH TOPS, INVERTS, OR CENTERS OF MATING PIPES INDICATED ON THE PLANS.
2. MINIMUM LENGTHS ARE SHOWN.
3. PIPE STRENGTH REQUIREMENTS TO BE DETERMINED FROM CITY OF ROCKLIN IMPROVEMENT STANDARDS.
4. MINIMUM LENGTHS SHALL BE ADJUSTED AS REQUIRED TO PROVIDE FOR COUPLING BANDS.
5.  $\delta$  SHALL NOT EXCEED 45°
6.  $\beta$  SHALL NOT EXCEED 90°

D1	A (IN.)
24" TO 36"	$D_2/2+14$
42"	"
48"	"
60"	"
66"	"
72"	"
78"	"
84"	"

*[Signature]*  
DRAWING APPROVED – CITY ENGINEER

*[Signature]*

DRAWING APPROVED – DIRECTOR OF PUBLIC SERVICES

**CITY OF ROCKLIN**  
**ENGINEERING DIVISION**

CORRUGATED  
PIPE  
FITTINGS

SCALE: NONE  
DATE: AUGUST 2015  
DRAWN BY: J. PINKHAM

DWG #  
4-22

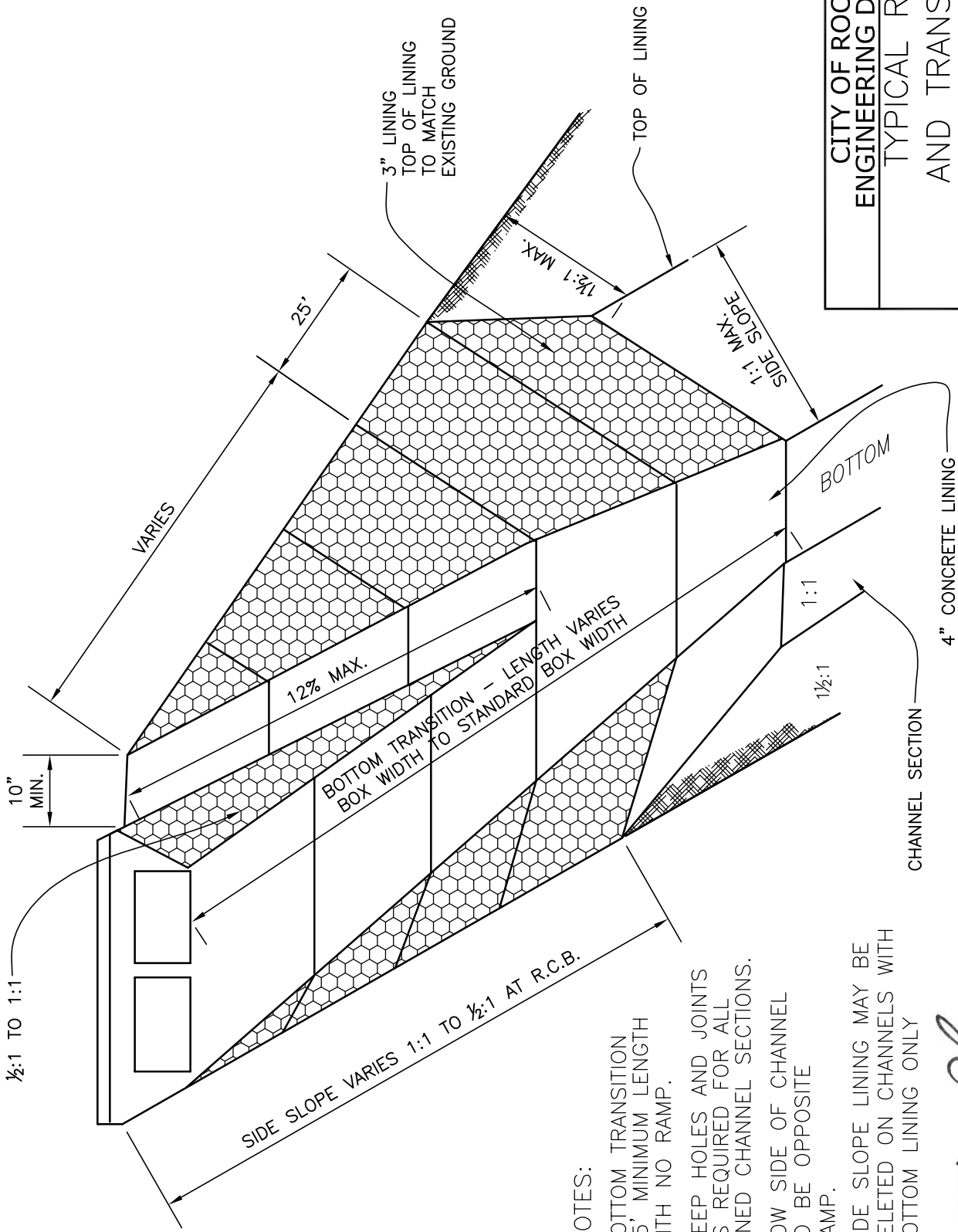

**NOTES:**

- BOTTOM TRANSITION 25' MINIMUM LENGTH WITH NO RAMP.
- WEEP HOLES AND JOINTS AS REQUIRED FOR ALL LINED CHANNEL SECTIONS.
- LOW SIDE OF CHANNEL TO BE OPPOSITE RAMP.
- SIDE SLOPE LINING MAY BE DELETED ON CHANNELS WITH BOTTOM LINING ONLY

*[Signature]*  
DRAWING APPROVED – CITY ENGINEER

*[Signature]*  
DRAWING APPROVED – DIRECTOR OF PUBLIC SERVICES

CITY OF ROCKLIN ENGINEERING DIVISION		DWG #
TYPICAL RAMP AND TRANSITION DETAIL		4-23
SCALE: NONE	DATE: AUGUST 2015	
DRAWN BY: J. PINKHAM		

NO DUMPING !  
 FLOWS TO CREEK

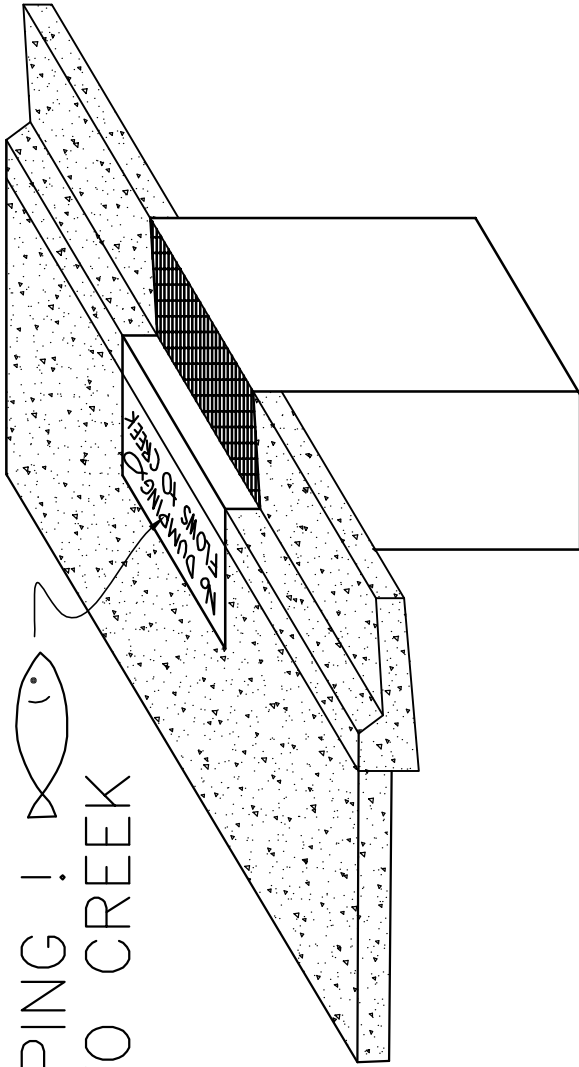

1. Clean Surface  
 Make sure application surface is flat, dry and free of any loose debris.
2. Apply Adhesive  
 Coming in 1/8" from the outside edge of the marker, apply a bead of adhesive and then work in to the center.
3. Stick It!  
 Apply the marker to the application surface pushing down HARD forcing adhesive out around the entire edge. It is important that the entire edge of the marker is sealed to the application surface.

DRAIN INLETS WITHIN CITY RIGHT OF WAY

NOTES

1. STORM DRAIN MESSAGE SHALL BE APPROVED BY THE CITY OF ROCKLIN, ENGINEERING DIVISION.
2. STORM DRAIN MESSAGE SHALL BE APPLIED IN SUCH A WAY AS TO PROVIDE A CLEAR, LEGIBLE IMAGE STAMPED IN CONCRETE. THE DEPTH SHOULD BE APPROXIMATELY 0.25".
3. MESSAGE SHALL APPEAR ON ALL STORM DRAIN INLETS.

STORM DRAIN MESSAGE

DRAWING APPROVED - DIRECTOR OF PUBLIC SERVICES

DRAIN INLETS FOR COMMERCIAL PROJECTS OR ONSITE

DRAWING APPROVED - CITY ENGINEER

**CITY OF ROCKLIN  
 ENGINEERING DIVISION**

TYPICAL STORM  
 DRAIN INLET  
 STAMP

SCALE: NONE	DWG #
DATE: AUGUST 2015	4-24
DRAWN BY: J. PINKHAM	

4" P.V.C SCREW CAP OR MECHANICAL WING NUT PLUG, CHERNE INDUS., OR APPROVED EQUAL. INSTALL FLUSH TO GRADE

4" P.V.C NONPERFORATED STANDPIPE

USE 45° WYE AND FITTING OR EQUIVALENT DIRECTIONAL CLEANOUT TO CONNECT UNDERDRAIN TO STANDPIPE

4" PERFORATED SCHED 40 P.V.C UNDERDRAIN PERFORMATIONS FACING DOWN

BIOTREATMENT SOIL MIX (BSM) PER SPECS. DO NOT MECHANICALLY COMPACT.

IF NATIVE MATERIAL IS USED FOR SIDESLOPE, RELATIVE COMPACTION OF SUBGRADE TO BE SIMILAR TO ADJOINING NATIVE SOILS. 33.3% MAX SIDE SLOPE

CLASS II PERMABLE ROCK PER CALTRANS SPECIFICATIONS

WATERTIGHT CAP ON TERMINAL END OF PIPE

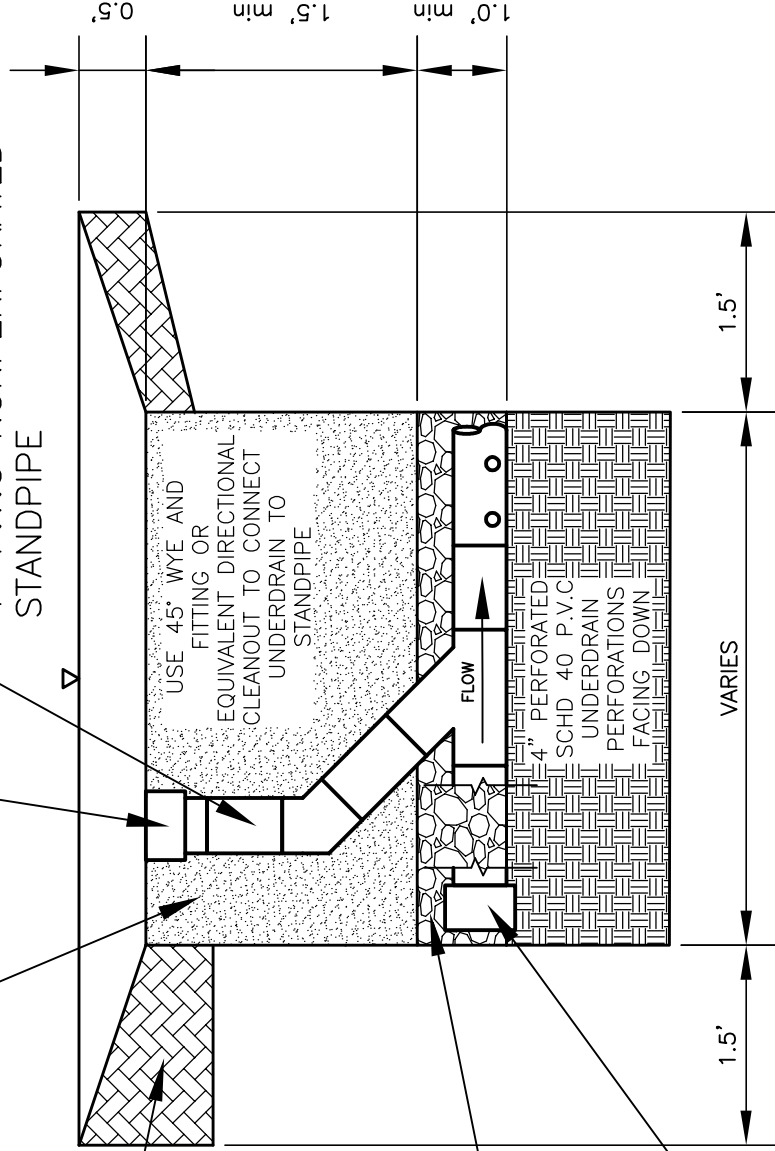

CITY OF ROCKLIN  
ENGINEERING DIVISION

4" P.V.C CLEANOUT DETAIL

SCALE: NONE  
DATE: AUGUST 2016  
DRAWN BY: J. PINKHAM

DWG #  
4-25

*[Signature]*  
DRAWING APPROVED - CITY ENGINEER

*[Signature]*  
DRAWING APPROVED - DIRECTOR OF PUBLIC SERVICES

**MAXIMUM TRENCH DEPTH**

MEASURED SURFACE TO BOTTOM OF TRENCH IN FEET

DIAMETER	C-14 CONC. PIPE -CLASS-		REINFORCED CONCRETE PIPE -CLASS-					HDPE	CAST IN PLACE
	1	2	3	I	II	III	IV		
10	12	17	29		8	12	30		NO LIMIT
12	12	17	21		10	15	35		
15	12	17	20		11	16	38		
18	11	17	19		12	17	39		
21	11	17	19		12	18	39		
24	11	16	19		13	19	39		
27	11	16	18		14	19	38		
30	11	15	17		14	20	38		
33	11	15	16		13	17	27		
36	10	13	14		14	18	29		
42					15	19	30	69	
48					16	20	31	58	
54					16	21	31	57	
60				14	17	22	32	56	
66				15	18	23	33	56	
72				15				56	
									45
									35
									30

**NOTES:**

1. ALL DEPTHS SHOWN ARE FLEXIBLE PAVEMENT AND TRENCH WIDTH EQUAL TO O.D. OF PIPE PLUS 16" FOR PIPE 33" AND SMALLER IN INSIDE DIAMETER. TRENCH WIDTH EQUALS O.D. OF PIPE PLUS 24" FOR PIPE 36" AND LARGER IN INSIDE DIAMETER. TRENCH WIDTH MEASURED AT TOP OF PIPE.

2. ALL PIPE SHALL BE INSTALLED PER MANUFACTURER'S RECOMMENDATIONS OR PER THIS TABLE, WHICHEVER IS MORE STRINGENT.



DRAWING APPROVED - DIRECTOR OF PUBLIC SERVICES

**MINIMUM COVER**  
MEASURED SURFACE TO TOP OF PIPE IN INCHES

TYPE	CLASS	MIN. COVER	
		STREET	OFF ST.
C-14 CONC. PIPE	1	30	12
	2	27	12
	3	24	12
REINFORCED CONCRETE	I	27	12
	II	24	12
	III	18	12
	IV	12	12
	V	12	12
HDPE	PER CALTRANS STANDARD, SECTION 64, LATEST EDITION		
CAST-IN PLACE CONC. PIPE	-----	12	12



DRAWING APPROVED - CITY ENGINEER

**CITY OF ROCKLIN  
ENGINEERING DIVISION**

**CONC. PIPE, REINF. CONC. PIPE,  
HDPE AND CAST-IN-PLACE  
CONC. PIPE COVER REQ.**

**SCALE: NONE**

**DATE: DECEMBER 2015**

**DRAWN BY: J. PINKHAM**

**DWG #**

**5-1**



THICKNESS IN INCHES		CORRUGATED STEEL PIPE (C.S.P.)**						CORRUGATED ALUMINUM PIPE (C.A.P.)*									
		0.064	0.079	0.109	0.138	0.168	0.060	0.075	0.105	0.135	0.165						
10							40										
12	100						35	40	50								
15	100						32	35	40								
18	100						26	30	35								
21	91		100				21	25	30								
24	80		100				13	21	30								
27	64		80				13	20	27								
30	64		80	100			12	19	25	30							
33	53		66	93				16	20	27							
36	53		66	93	100			15	18	25							
42	46		57	80	100			13	15	20							
48	40	48	50	70	86	100			15	18							
54	43	44	62	62	75	98			13	15							
60	39	49	56	69	72	88				10							
66	35	44	51	62	64	78				10							
72	32	41	56	55	68	68				10							

NOT PERMITTED

NOTES:

- 1.)\*\*--NORMAL PIPE CORRUGATION PROFILE IS 2 2/3" x 1". THE CORRUGATION OF THE PIPES WITHIN THE SHADED AREA SHALL HAVE PROFILE OF 3" x 1".
- 2.)\*--ALUMINUM PIPE IS NOT PERMITTED IN PUBLIC STREET RIGHT OF WAY.
- 3.) WHEN FLOW VELOCITY EXCEEDS FIVE (5) F.P.S. THICKER METAL SHALL BE PROVIDED.
- 4.) ALL PIPE SHALL BE INSTALLED PER MANUFACTURER'S RECOMMENDATIONS OR PER THIS TABLE, WHICHEVER IS MORE STRINGENT.





DRAWING APPROVED -- CITY ENGINEER

DRAWING APPROVED -- DIRECTOR OF PUBLIC SERVICES

CITY OF ROCKLIN ENGINEERING DIVISION	
CORRUGATED STEEL AND ALUMINUM PIPE COVER REQUIREMENTS	
SCALE: NONE	DWG #
DATE: DECEMBER 2015	5-2
DRAWN BY: J. PINKHAM	

TRENCH EXCAVATION

REPLACE WITH 12"AC, OR 8"AC OVER 4"AB ON MINOR AND PRIMARY ARTERIAL, OR 4"AC OVER 8"AB ON COLLECTOR AND RESIDENTIAL PER SECTION 4 "STREET SECTIONS" OF THE IMPROVEMENT STANDARDS

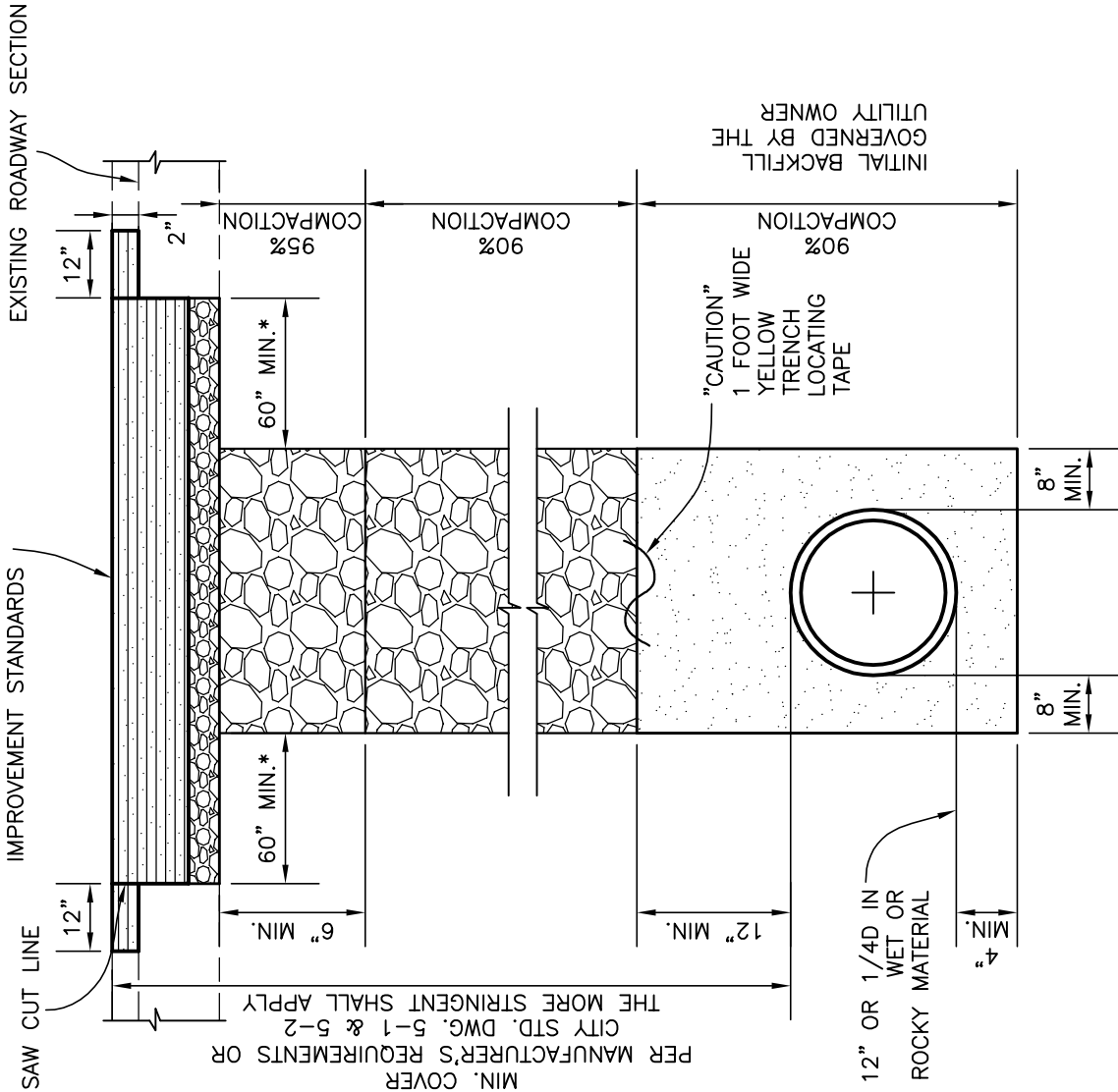

MIN. COVER PER MANUFACTURER'S REQUIREMENTS OR CITY STD. DWG. 5-1 & 5-2 THE MORE STRINGENT SHALL APPLY

TRENCH BACKFILL

TRENCH INTERMEDIATE BACKFILL PER CONSTRUCTION SPECIFICATIONS

FOR TRENCH BEDDING AND INITIAL BACKFILL FOR DRAINAGE SEE SECTION SS-11 OF THE SPECIFICATIONS. INITIAL BACKFILL FOR ALL OTHER UTILITIES TO BE PER RESPECTIVE UTILITY SPECS

STREET REPAIR/REPAVING

- A) STREET AGE \*\* 0-5 YRS:  
THE CONTRACTOR SHALL GRIND AND PLACE BACK TWO (2) INCHES OF THE WEARING COURSE OVER THE ENTIRE WIDTH OF THE STREET. IF THE TRENCH IS CLOSE TO THE GUTTER, THE CITY ENGINEER OR DESIGNER MAY ALLOW A VARIANCE.
  - B) STREET AGE 6-10 YRS:  
THE CONTRACTOR SHALL PLACE A TYPE II MICRO OVER THE FULL WIDTH OF THE STREET.
  - C) STREET AGE 11 YRS AND OLDER:  
RESTORE THE TRENCH PER THIS STANDARD DRAWING. IF THE TRENCH FALLS IN THE MIDDLE OF THE INSIDE LANE, THE LIMITS SHOULD EXTEND TO THE LANE LINE.
- \*\* STREET AGE SHALL BE BASED ON WHEN THE STREET WAS FIRST CONSTRUCTED, RE-CONSTRUCTED, OR LAST RECEIVED AN ASPHALT OVERLAY

FOR REPAIR AND REPAVING REQUIREMENTS SEE SECTIONS SS9-04 AND SS30-04

*[Signature]*  
DRAWING APPROVED - CITY ENGINEER

DRAWING APPROVED - DIRECTOR OF PUBLIC SERVICES

CITY OF ROCKLIN  
ENGINEERING DIVISION

TRENCH  
EXCAVATION &  
BACKFILL

SCALE: NONE  
DATE: MAY 2016  
DRAWN BY: J. PINKHAM

DWG #  
5-3

\* WHERE WIDTH CONSTRAINTS APPLY, THE CITY ENGINEER OR DESIGNER MAY APPROVE A DEVIATION

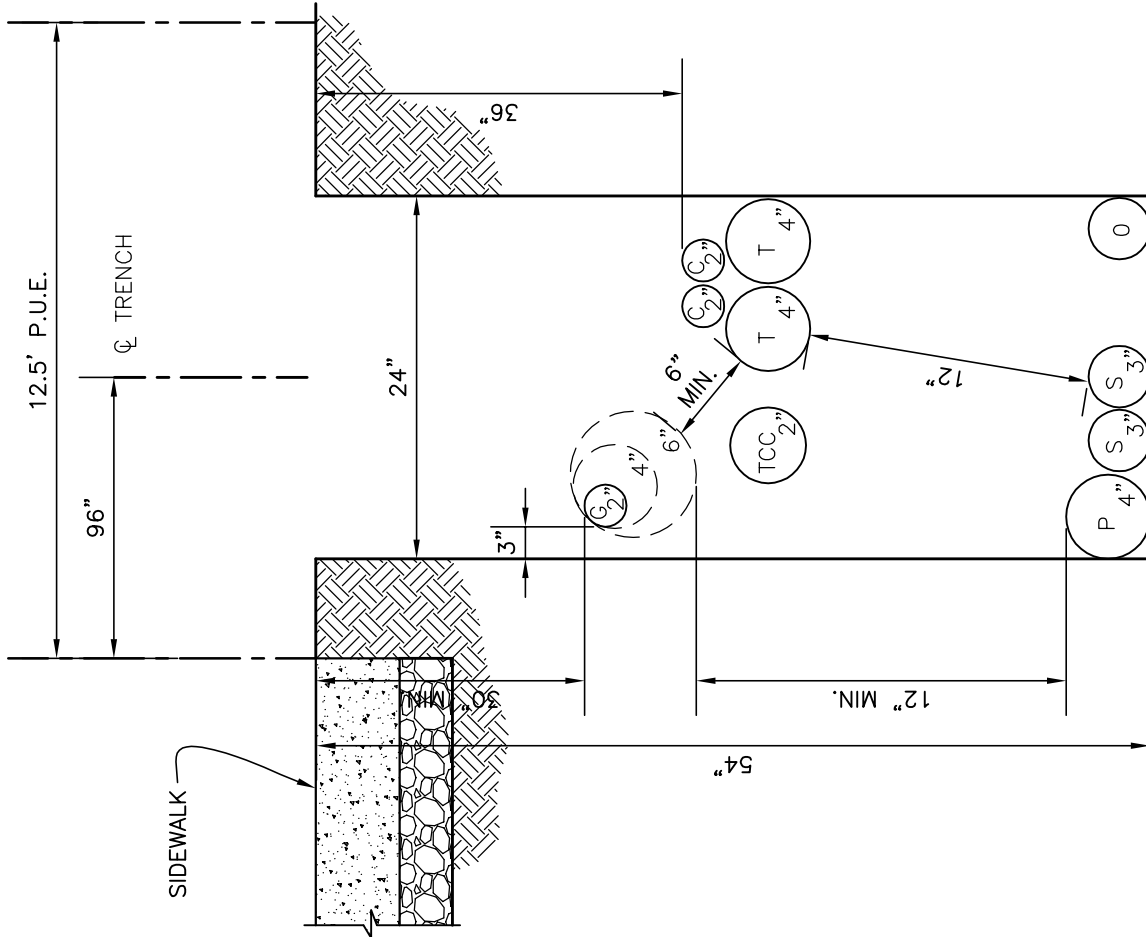

NOTE:  
 TYPICAL CONFIGURATION SHOULD WORK FOR MOST IDEAL TRENCHING SITUATIONS. FIELD CONDITIONS MAY DICTATE A NEED FOR ALTERNATIVE TRENCH DESIGN BASED ON P.U.E. WIDTH. SUBJECT TO PG&E INSPECTOR APPROVAL.

LEGEND

- G — GAS
- P — PRIMARY
- S — SECONDARY
- T — TELEPHONE
- C — CATV
- O — STREET LIGHT
- TCC — TELECOMMUNICATIONS CONDUIT WITH CONTINUOUS #10 GREEN OR COPPER WIRE

*[Signature]*

DRAWING APPROVED — CITY ENGINEER

*[Signature]*

DRAWING APPROVED — DIRECTOR OF PUBLIC SERVICES

CITY OF ROCKLIN  
 ENGINEERING DIVISION

TYPICAL  
 JOINT TRENCH  
 CONFIGURATION

SCALE: NONE	DWG #
DATE: DECEMBER 2015	5-4
DRAWN BY: J. PINKHAM	

Design of water facilities shall conform to the requirements set forth in the most recent standards of the Placer County Water Agency (PCWA), the National Fire Protection Association (NFPA 24), and the City of Rocklin Fire & Life Safety Standards.

CITY OF ROCKLIN  
ENGINEERING DIVISION

FIRE  
STANDARDS

SCALE: NONE	DWG #
DATE: OCTOBER 2016	6-1
DRAWN BY: J. PINKHAM	

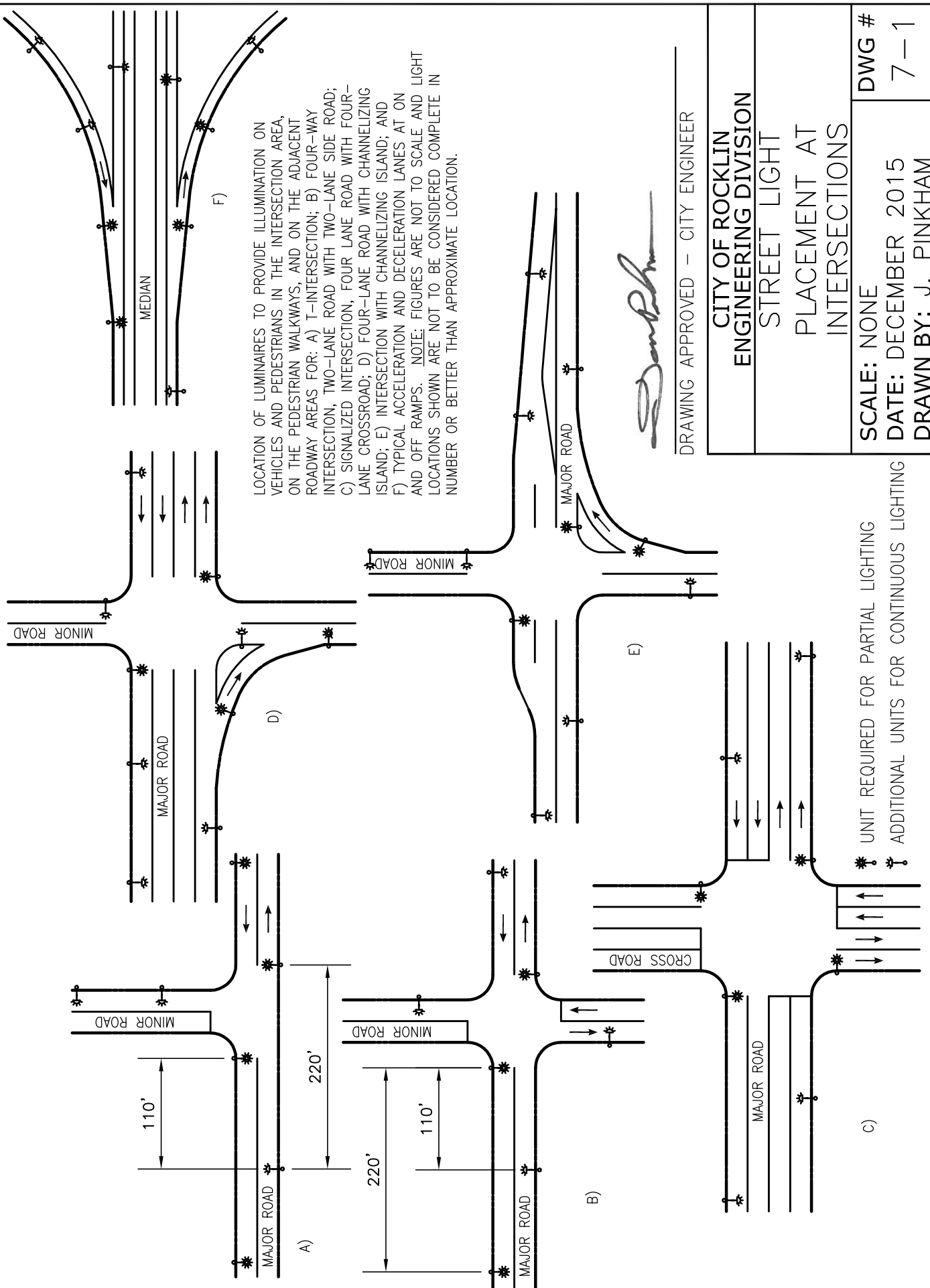

LOCATION OF LUMINAIRES TO PROVIDE ILLUMINATION ON VEHICLES AND PEDESTRIANS IN THE INTERSECTION AREA, ON THE PEDESTRIAN WALKWAYS, AND ON THE ADJACENT ROADWAY AREAS FOR: A) T-INTERSECTION; B) FOUR-WAY INTERSECTION, TWO-LANE ROAD WITH TWO-LANE SIDE ROAD; C) SIGNALIZED INTERSECTION, FOUR LANE ROAD WITH FOUR-LANE CROSSROAD; D) FOUR-LANE ROAD WITH CHANNELIZING ISLAND; E) INTERSECTION WITH CHANNELIZING ISLAND; AND F) TYPICAL ACCELERATION AND DECELERATION LANES AT ON AND OFF RAMP. NOTE: FIGURES ARE NOT TO SCALE AND LIGHT LOCATIONS SHOWN ARE NOT TO BE CONSIDERED COMPLETE IN NUMBER OR BETTER THAN APPROXIMATE LOCATION.

*J. Pinkham*

DRAWING APPROVED - CITY ENGINEER \_\_\_\_\_

CITY OF ROCKLIN ENGINEERING DIVISION		DWG #
STREET LIGHT PLACEMENT AT INTERSECTIONS		7-1
SCALE: NONE	DATE: DECEMBER 2015	
DRAWN BY: J. PINKHAM		

UNIT REQUIRED FOR PARTIAL LIGHTING  
ADDITIONAL UNITS FOR CONTINUOUS LIGHTING

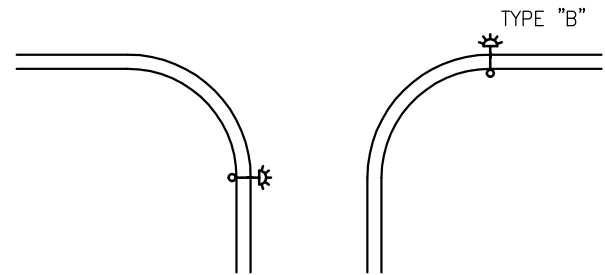
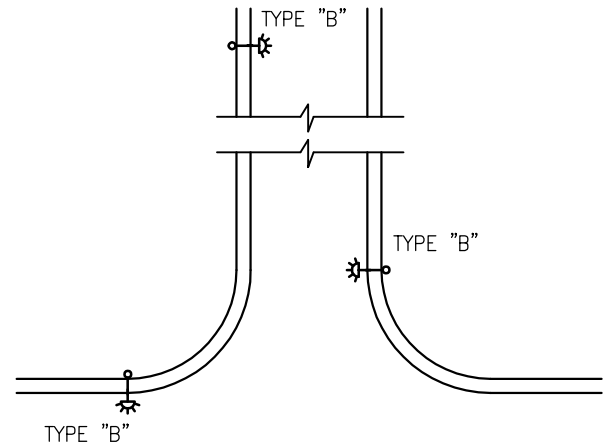
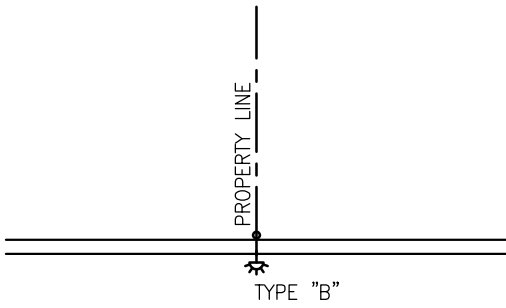

RESIDENTIAL

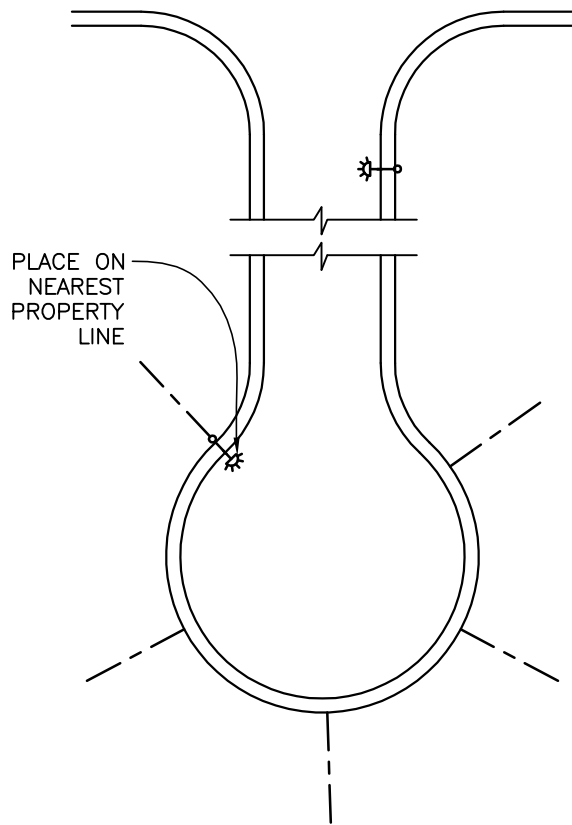

CUL-DE-SAC

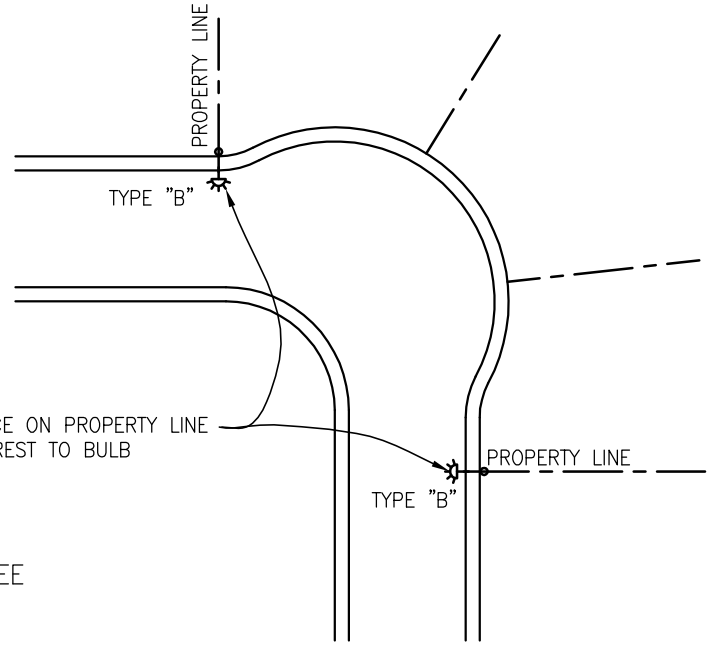

RESIDENTIAL

NOTE:  
FOR STREET LIGHT SPACING REQUIREMENTS, SEE  
STANDARD DRAWING 7-1 AND 7-17.

DRAWING APPROVED - CITY ENGINEER

<b>CITY OF ROCKLIN ENGINEERING DIVISION</b>	
STREET LIGHT LOCATIONS ON RESIDENTIAL STREETS	
<b>SCALE: NONE</b> <b>DATE: DECEMBER 2015</b> <b>DRAWN BY: J. PINKHAM</b>	<b>DWG #</b> 7-2

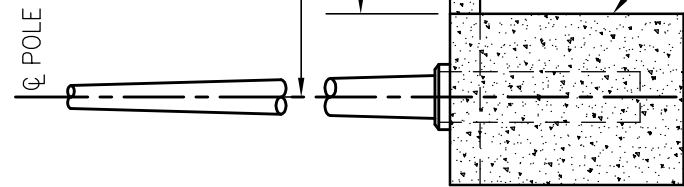

4' SIDEWALK

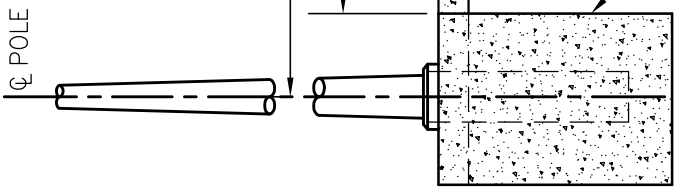

6' SIDEWALK

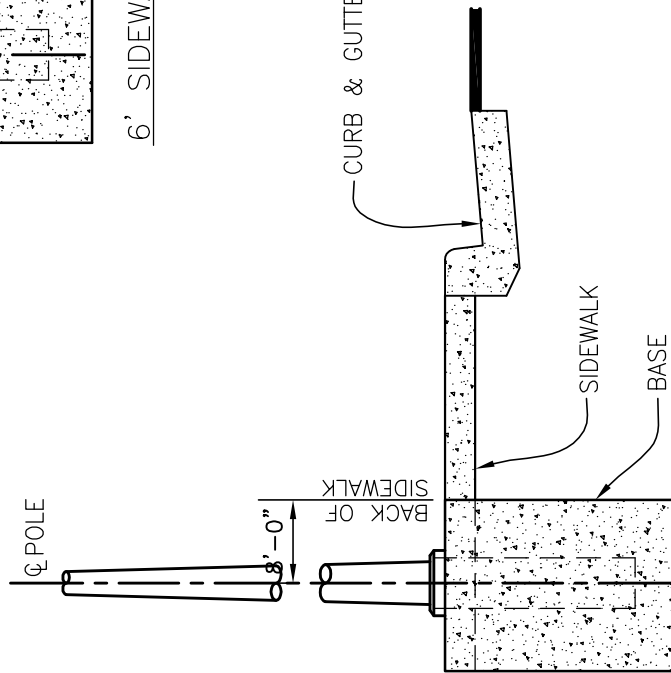

VARIABLE SIDEWALK WIDTH  
(OVER 6')

*J. Pinkham*

DRAWING APPROVED - CITY ENGINEER

CITY OF ROCKLIN  
ENGINEERING DIVISION

BASE LOCATION

FOR  
STREET LIGHTS

SCALE: NONE

DATE: DECEMBER 2015

DRAWN BY: J. PINKHAM

DWG #  
7-3

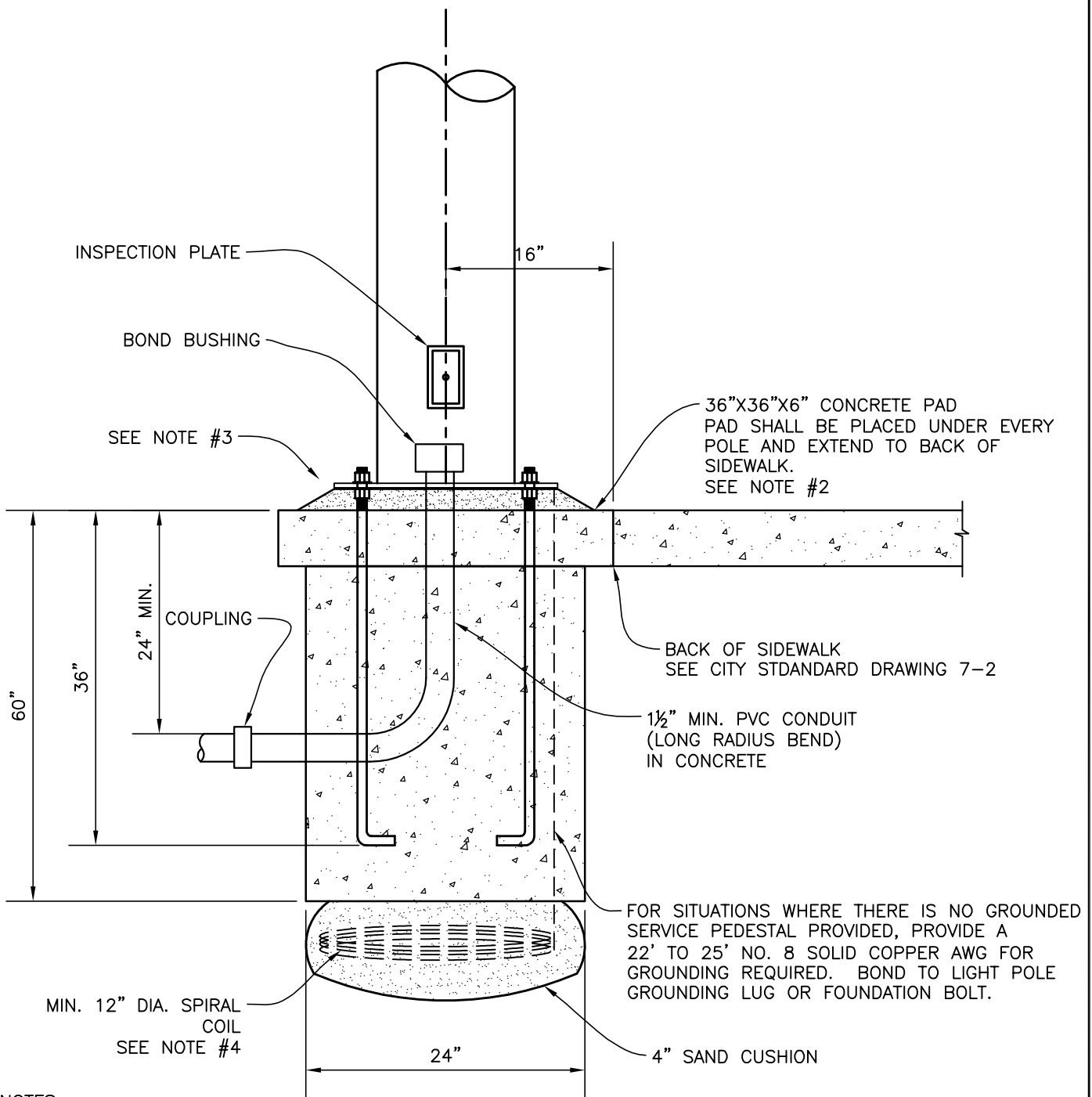

**NOTES:**

1. DESIGN SHALL CONFORMS TO THESE REQUIREMENTS EXCEPT AS OTHERWISE APPROVED BY THE CITY ENGINEER BY VARIANCE.
2. FOR AREAS WITHOUT SIDEWALK ADJACENT TO TRAVELED WAY, CONSTRUCT A 36"X36" CONCRETE PAD 6" THICK.
3. LEVELING OF BASE SHALL CONFORM TO THE REQUIREMENTS OF CITY STANDARD DRAWING 7-17.
4. 12" DIAMETER SPIRAL COIL REQUIRED ON DIRECT SERVICE CONNECTION ONLY. SEE CITY STANDARD DRAWING 7-18.

*[Signature]*  
 DRAWING APPROVED - CITY ENGINEER

<b>CITY OF ROCKLIN ENGINEERING DIVISION</b>	
<b>CONCRETE BASE DETAIL FOR TYPE "A" AND "B" STREET LIGHTS</b>	
<b>SCALE: NONE</b>	<b>DWG #</b>
<b>DATE: DECEMBER 2015</b>	<b>7-4</b>
<b>DRAWN BY: J. PINKHAM</b>	



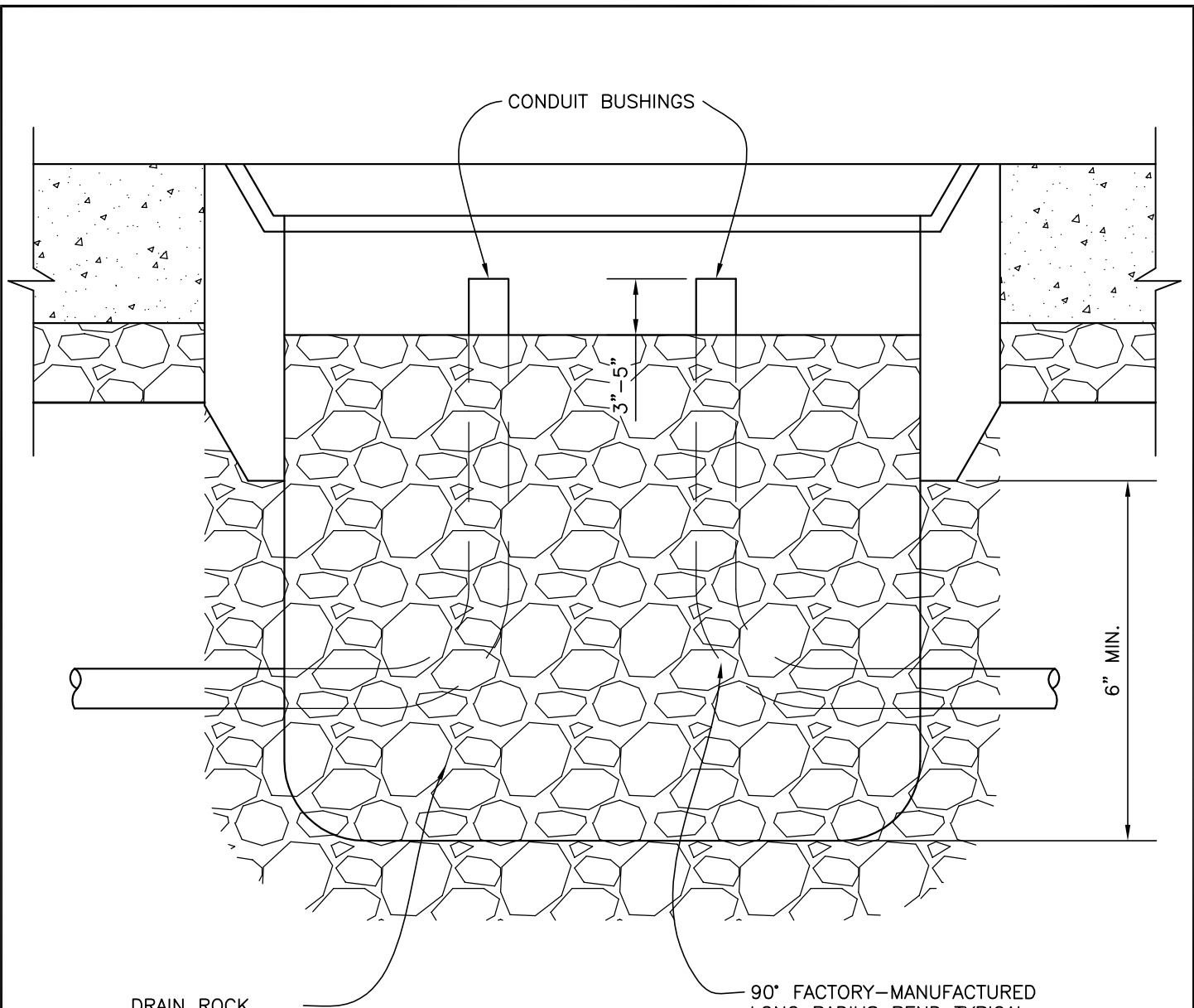

DRAIN ROCK SHALL EXTEND 6" BELOW AND 6" TO ALL SIDES OF ALL BOXES

## NO. 3 1/2 & 5 PULL BOX

**NOTES:**

1. DESIGN SHALL CONFORM TO THESE REQUIREMENTS EXCEPT OTHERWISE APPROVED BY THE CITY ENGINEER BY VARIANCE.
2. PULLBOX COVERS SHALL BE BOLTED AND INSCRIBED "STREET LIGHTING".
3. ALL PULLBOXES SHALL BE ENCOMPASSED BY 6" CURB MINIMUM.
4. SEE CITY STANDARD DRAWING 7-6 FOR CURB DETAIL.
5. CONDUIT BUSHINGS TO BE INSTALLED ON ALL CONDUIT ENDS
6. ALL CONDUIT ENDS TO BE SEALED WITH DUCT SEAL

DRAWING APPROVED - CITY ENGINEER

<b>CITY OF ROCKLIN ENGINEERING DIVISION</b>	
NO. 3 1/2 AND NO. 5 PULL BOX INSTALLATION	
SCALE: NONE	DWG #
DATE: DECEMBER 2015	7-5
DRAWN BY: J. PINKHAM	

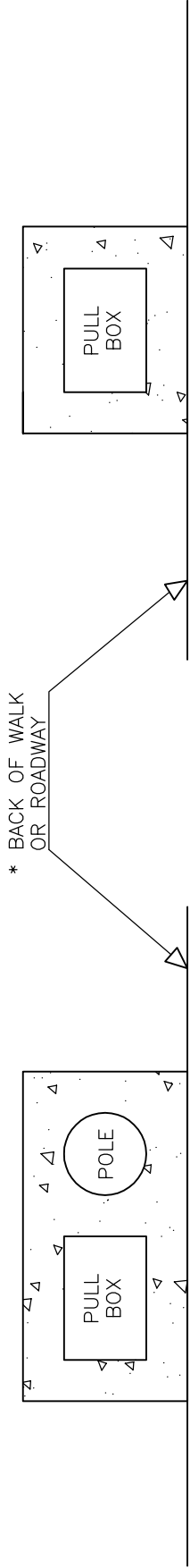

\*\* CONCRETE COLLAR/CAP TO SURROUND PULL BOX & POLE 6" MINIMUM WITH 6" CONCRETE DEPTH. (THICKNESS)

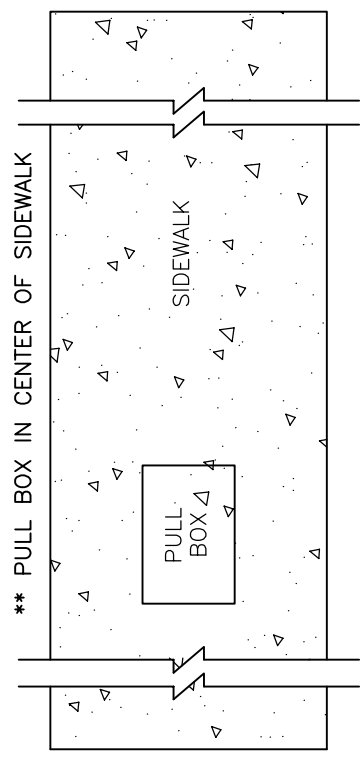

\*\* PULL BOX IN CENTER OF SIDEWALK

NOTES:

1. SEE CITY STANDARD DRAWING 7-5 FOR PULL BOX INSTALLATION SPECIFICATIONS.
2. SEE CITY STANDARD DRAWING 7-4 FOR CONCRETE BASE DETAIL.
3. PULL BOX AT EACH STREET LIGHT AND LATERAL STREET CROSSING.

CITY OF ROCKKLIN ENGINEERING DIVISION	
STREET LIGHT AND SIGNAL PULL BOX LOCATIONS	
SCALE: NONE	DWG #
DATE: DECEMBER 2015	7-6
DRAWN BY: J. PINKHAM	

*J. Pinkham*  
DRAWING APPROVED - CITY ENGINEER

STREET LIGHT  
PEDESTAL PAD

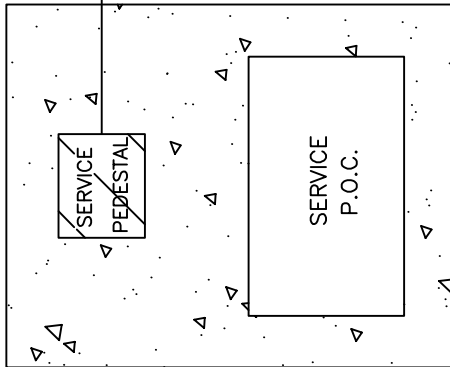

REFER TO  
DRAWING  
7-8

STREET LIGHT &  
IRRIGATION PAD

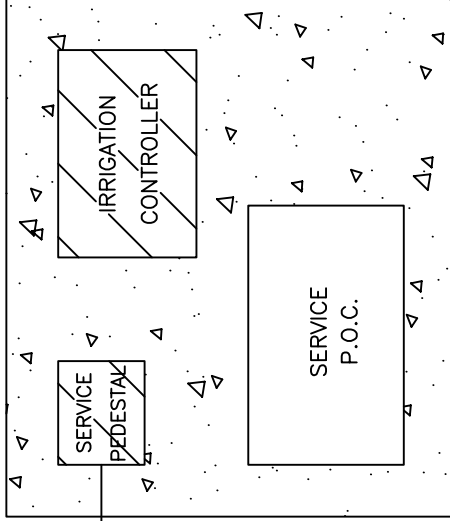

\* BACK OF WALK  
OR ROADWAY

DRAWING APPROVED - CITY ENGINEER

\*\* NOTE - UTILITY (PG&E)  
P.O.C (POINT OF CONNECTION) SHALL BE  
NO MORE THAN FIVE FEET FROM ANY SERVICE.  
P.O.C. BOX & CONDUIT SHALL BE INSTALLED  
PER CURRENT PG&E GREEN BOOK STANDARDS.

CITY OF ROCKLIN  
ENGINEERING DIVISION

TYPICAL

STREET LIGHT  
SERVICE PAD

SCALE: NONE

DATE: DECEMBER 2015

DRAWN BY: J. PINKHAM

DWG #

7-7

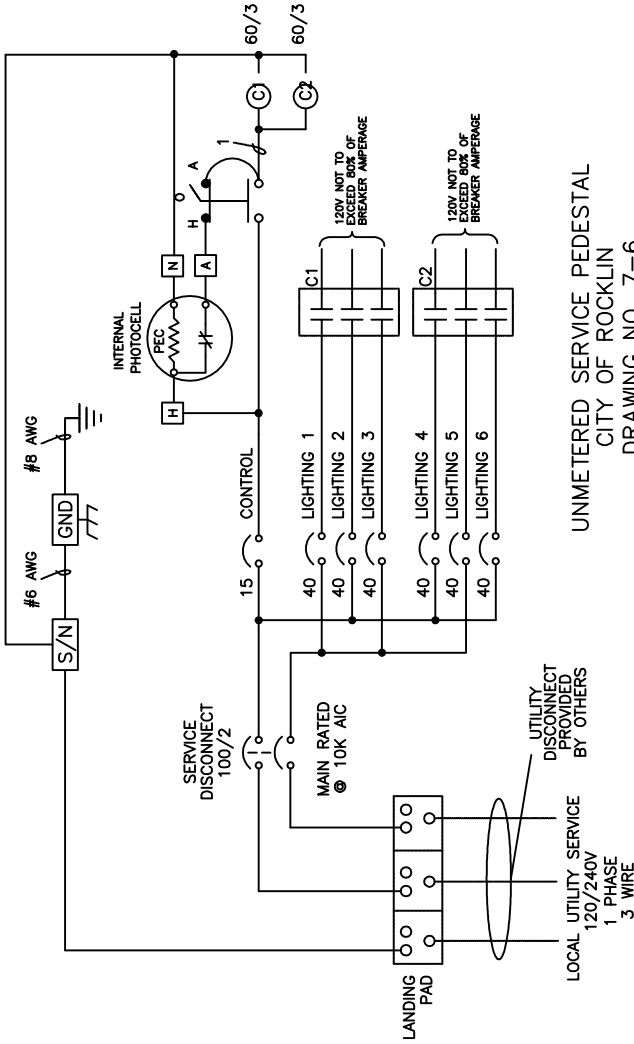

UNMETERED SERVICE PEDESTAL  
CITY OF ROCKLIN  
DRAWING NO. 7-6

NOTE: LOAD CURRENT FOR ALL BREAKERS NOT TO EXCEED 80% OF BREAKER AMPERAGE

ENCLOSURE CONSTRUCTION NOTES

1. EXTERIOR, 1/8" ALUMINUM, AND INTERIOR 14 GA. COLD ROLLED STEEL ELECTRICALLY WELDED AND REINFORCED WHERE REQUIRED.
2. CONSTRUCTION WILL BE NEMA 3R, RAIN TIGHT.
3. ALL NUTS, BOLTS & SCREWS WILL BE STAINLESS STEEL.
4. NUTS, BOLTS & SCREWS WILL NOT BE VISIBLE FROM OUTSIDE OF ENCLOSURE.
5. NAMEPLATES WILL BE PROVIDED AS REQUIRED.
6. CONTROL WIRING WILL BE MARKED AT BOTH ENDS BY PERMANENT WIRE MARKERS.
7. A PLASTIC COVERED WIRING DIAGRAM WILL BE ATTACHED TO THE INSIDE OF THE FRONT DOOR.
8. ENCLOSURE WILL BE FACTORY WIRED AND CONFORM TO REQUIRED NEMA AND UL 508A STANDARDS.
9. ANODIZE AFTER FABRICATION

CITY OF ROCKLIN  
ENGINEERING DIVISION  
UNMETERED  
SERVICE  
PEDESTAL

SCALE: NONE  
DATE: DECEMBER 2015  
DRAWN BY: J. PINKHAM  
DWG # 7-8

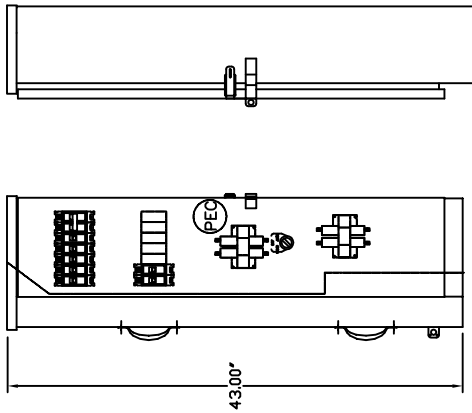

FRONT VIEW RIGHT SIDE

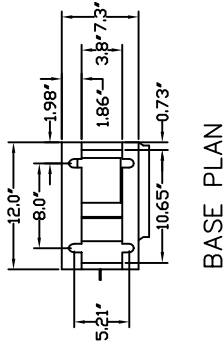

BASE PLAN

INDUSTRIAL CONTROL PANEL	
VOLTAGE	PHASE
120/240	1 3
AMPERES	AMPERES
3.500	100 60
<small>SUITABLE FOR USE IN A CIRCULAR CAPABLE OF BELT DRIVING NOT MORE THAN 1/2" IN DIAMETER</small>	
NET WEIGHT	MAX. Wt. - A. CONT.
11.5	240 V
<small>SUITABLE ONLY FOR USE AS SERVICE EQUIPMENT</small>	

DRAWING APPROVED - CITY ENGINEER

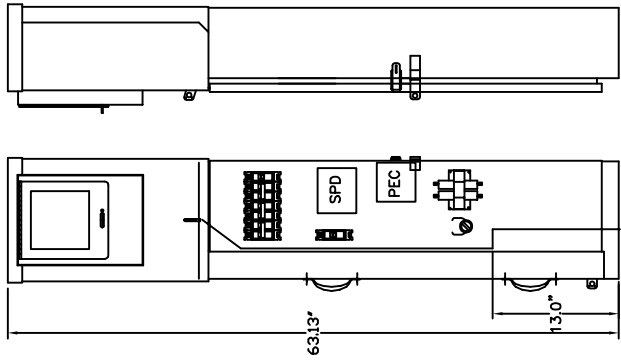

FRONT VIEW RIGHT SIDE

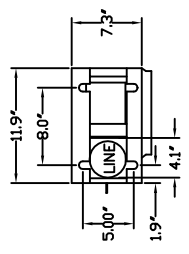

BASE PLAN

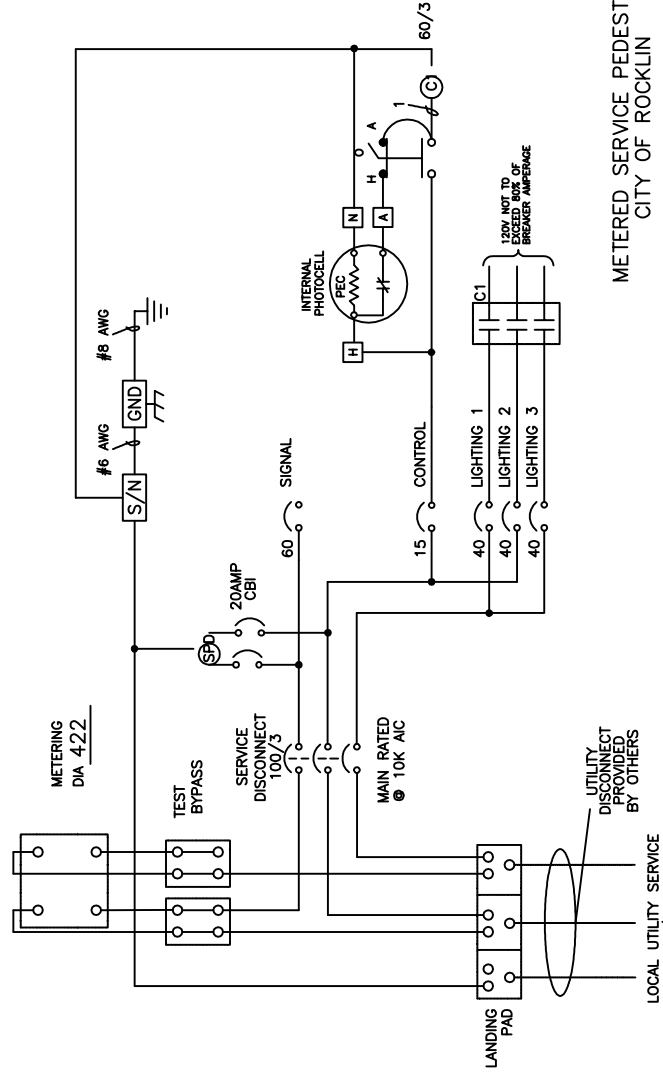

METERED SERVICE PEDESTAL  
CITY OF ROCKLIN

NOTE: LOAD CURRENT FOR ALL BREAKERS NOT TO EXCEED 80% OF BREAKER AMPERAGE

ENCLOSURE CONSTRUCTION NOTES

1. EXTERIOR, 1/8" ALUMINUM, AND INTERIOR 14 GA COLD ROLLED STEEL ELECTRICALLY WELDED AND REINFORCED WHERE REQUIRED.
2. CONSTRUCTION WILL BE NEMA 3R, RAIN TIGHT.
3. ALL NUTS, BOLTS AND SCREWS WILL BE STAINLESS STEEL.
4. NUTS, BOLTS & SCREWS WILL NOT BE VISIBLE FROM OUTSIDE OF ENCLOSURE.
5. NAMEPLATES WILL BE PROVIDED AS REQUIRED.
6. CONTROL WIRING WILL BE MARKED AT BOTH ENDS BY PERMANENT WIRE MARKERS.
7. A PLASTIC COVERED WIRING DIAGRAM WILL BE ATTACHED TO THE INSIDE OF THE FRONT DOOR.
8. ENCLOSURE WILL BE FACTORY WIRED AND CONFORM TO REQUIRED NEMA AND UL 508A STANDARDS.
9. ANODIZE AFTER FABRICATION

INDUSTRIAL CONTROL PANEL	
VOLTS	PHASE
120/240	1 3
AMPERS	100 60
SUITABLE FOR USE IN A CIRCUMSTANCE OF	
AMPERS	VOLTS
3-200	240 - V
METER BODY 100 - A CONT.	
SUITABLE ONLY FOR USE AS SERVICE EQUIPMENT	

CITY OF ROCKLIN ENGINEERING DIVISION	
METERED SERVICE PEDESTAL	
SCALE: NONE	DWG # 7-8A
DATE: DECEMBER 2015	
DRAWN BY: J. PINKHAM	

DRAWING APPROVED - CITY ENGINEER

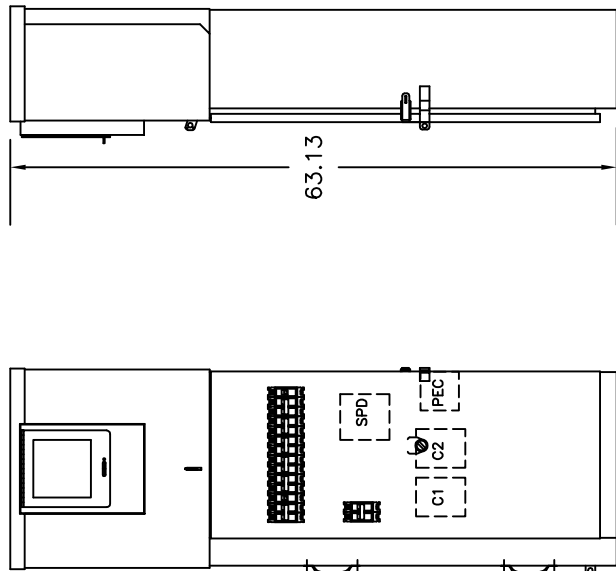

FRONT VIEW  
20.13

RIGHT SIDE  
63.13

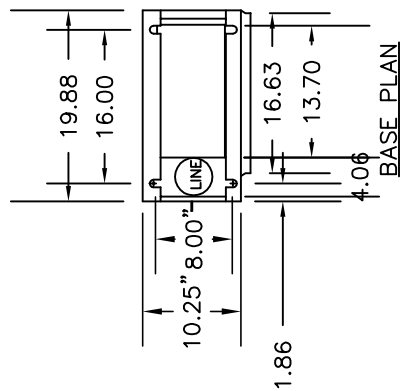

BASE PLAN

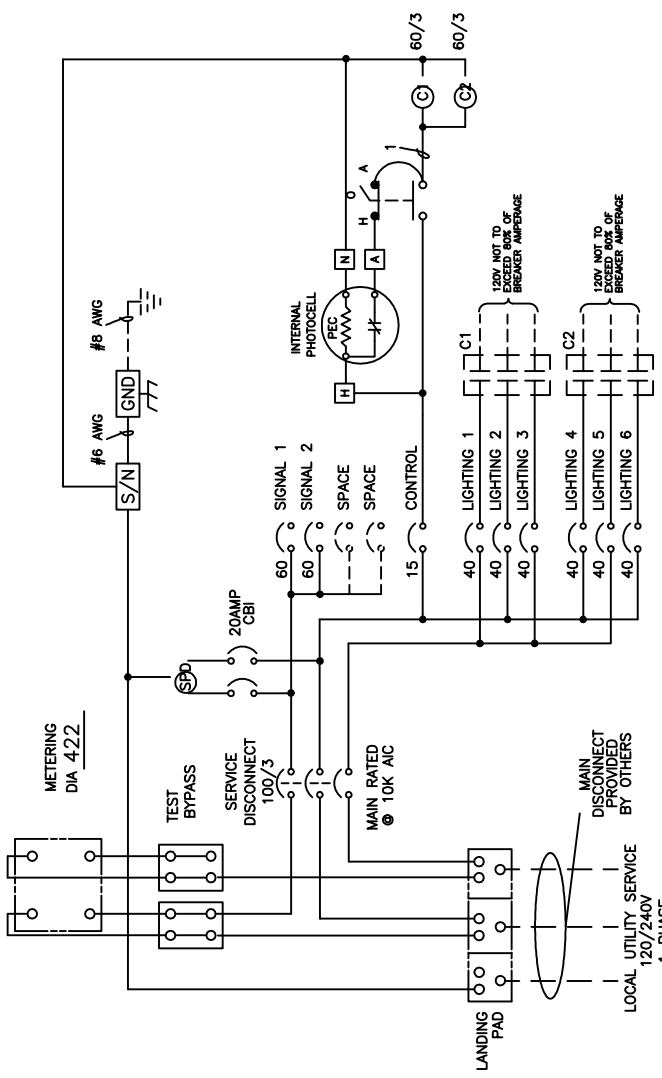

NOTE: LOAD CURRENT FOR ALL BREAKERS NOT TO EXCEED 80% OF BREAKER AMPERAGE

**ENCLOSURE CONSTRUCTION NOTES**

1. EXTERIOR 1/2" ALUMINUM INTERIOR 1/4" COLD ROLLED STEEL ELECTRICALLY GROUNDING REQUIRED WHERE REQUIRED.
2. CONSTRUCTION WILL BE NEMA 3R RAIN TIGHT.
3. ALL NUTS, BOLTS AND SCREWS WILL BE STAINLESS STEEL.
4. NUTS, BOLTS & SCREWS WILL NOT BE VISIBLE FROM OUTSIDE OF ENCLOSURE.
5. NAMEPLATES WILL BE PROVIDED AS REQUIRED.
6. CONTROL WIRING WILL BE MARKED AT BOTH ENDS BY PERMANENT WIRE MARKERS.
7. A PLASTIC COVERED WIRING DIAGRAM WILL BE ATTACHED TO THE INSIDE OF THE FRONT DOOR.
8. ENCLOSURE WILL BE FACTORY WIRED AND CONFORM TO REQUIRED NEMA AND UL 508A STANDARDS.
9. ANODIZE AFTER FABRICATION

TECHNO		TECHNO CONTROLS INC. 8110 W. 100th ST. MCKINNEY, TX	
INDUSTRIAL CONTROL PANEL		# 27-100	
VOLTAGE	PHASE	WIRES	AMPS
120/240	1	3	100
SUITABLE FOR USE ON A CIRCUIT CAPABLE OF DELIVERING NOT MORE THAN			
AMPERES	VOLTAGE	RMS SYM.	240
3,500	AT		V
METER SOCKET RATING 100 A CONT.			
ENCLOSURE TYPE 3R			

SUITABLE ONLY FOR USE AS SERVICE EQUIPMENT

CITY OF ROCKLIN  
ENGINEERING DIVISION

METERED  
SERVICE  
PEDESTAL

SCALE: NONE  
DATE: DECEMBER 2015  
DRAWN BY: J. PINKHAM

DWG #  
7-8B

DRAWING APPROVED - CITY ENGINEER

METER #1 120/240V, 1 $\phi$ , 3 WIRE  
 METER #2 120/240V, 1 $\phi$ , 3 WIRE

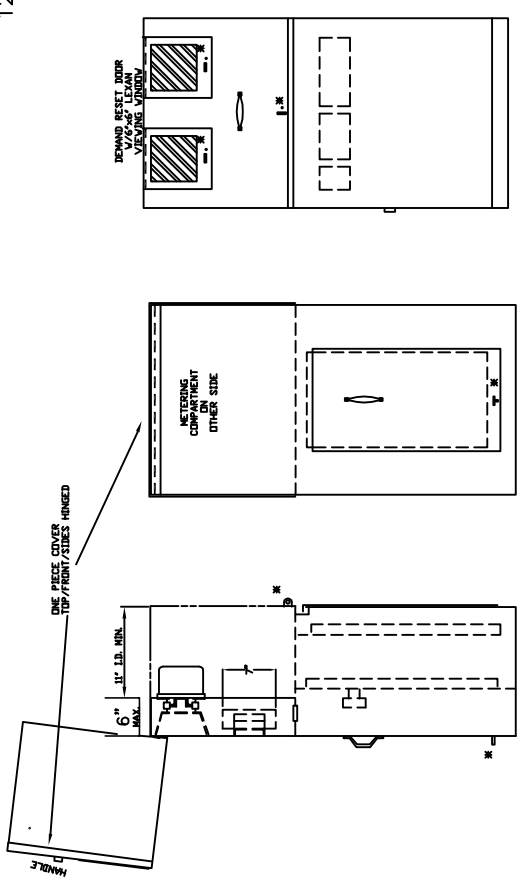
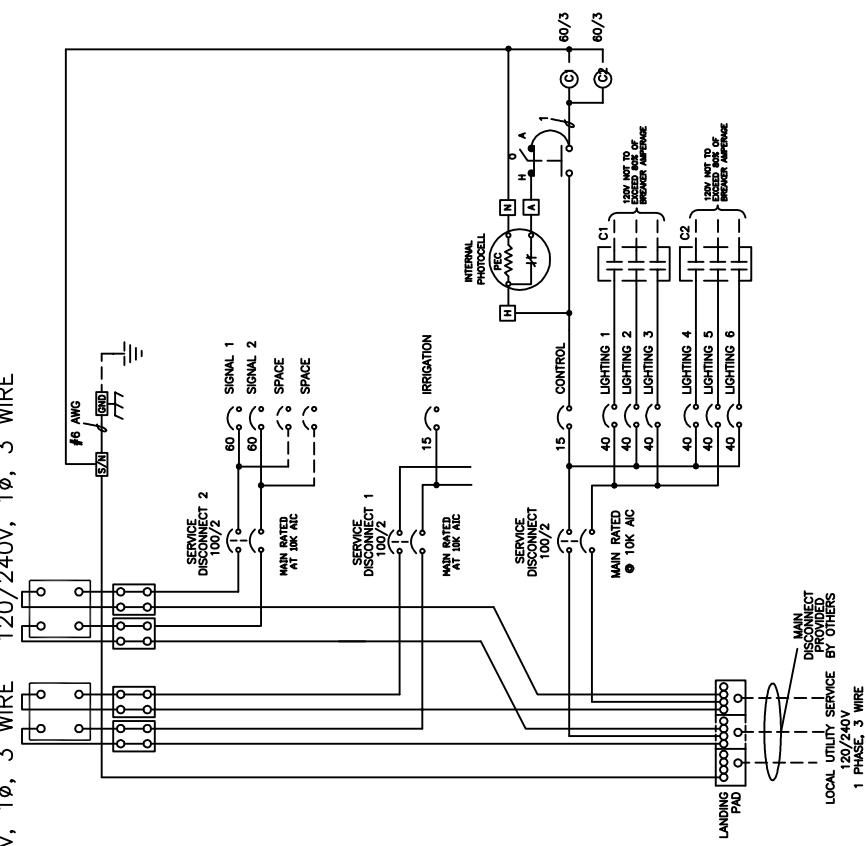

FRONT VIEW  
 WEATHERPROOF COVER  
 IN PLACE

REAR VIEW  
 GULL SECTION COVER IN PLACE

SIDE VIEW  
 IN OPEN POSITION

100-200 AMP COMMERCIAL METERING  
 0-600V SINGLE OR THREE PHASE

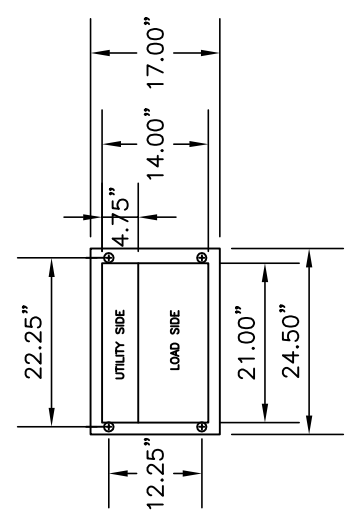

ENCLOSURE CONSTRUCTION NOTES

1. EXTERIOR, 1/8" ALUMINUM, AND INTERIOR 14 GA COLD ROLLED STEEL CONSTRUCTION WILL BE AS PROVIDED UNLESS OTHERWISE REQUIRED.
2. ALL NUTS, BOLTS AND SCREWS WILL BE STAINLESS STEEL.
3. NUTS, BOLTS & SCREWS WILL NOT BE VISIBLE FROM OUTSIDE OF ENCLOSURE.
4. NAMEPLATES WILL BE PROVIDED AS REQUIRED.
5. CONTROL WIRING WILL BE PROVIDED AT BOTH ENDS BY PERMANENT WIRE MARKERS.
6. A PLASTIC COVERED WIRING DIAGRAM WILL BE ATTACHED TO THE INSIDE OF THE FRONT DOOR.
7. THE ENCLOSURE WILL BE FACTORY WIRED AND CONFORM TO REQUIRED NEMA AND UL 508A STANDARDS.
8. ANODIZE AFTER FABRICATION

*[Signature]*  
 DRAWING APPROVED - CITY ENGINEER

CITY OF ROCKLIN  
 ENGINEERING DIVISION  
 DUAL METERED  
 SERVICE  
 PEDESTAL

SCALE: NONE  
 DATE: DECEMBER 2015  
 DRAWN BY: J. PINKHAM  
 DWG # 7-8C

TECHNO		INDUSTRIAL CONTROL PANEL	
120/240		VOLTS	PHASE
1	3	100	60
SUITABLE FOR USE ON A CIRCUIT CAPABLE OF DELIVERING NOT MORE THAN			
3,500	AMP	240	V
METER SOCKET RATING 100 A. CONT.			
ENCLOSURE TYPE 3B			

SUITABLE ONLY FOR USE AS SERVICE EQUIPMENT

TYPICAL  
STREET LIGHTS

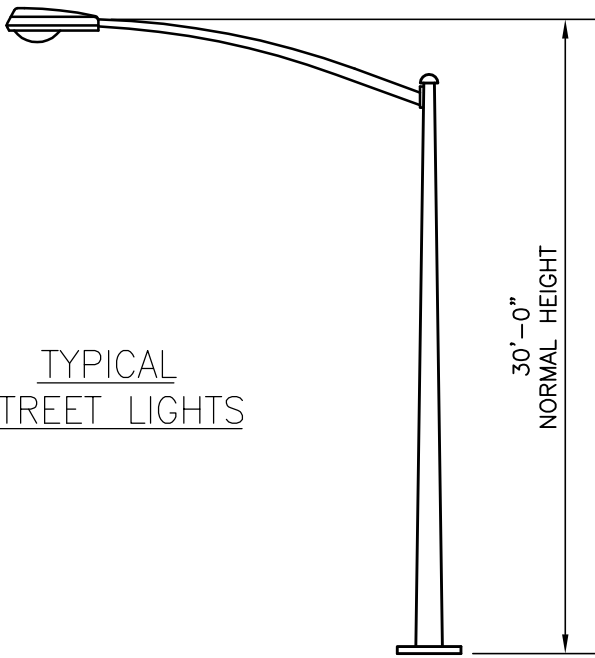

TYPE "A"

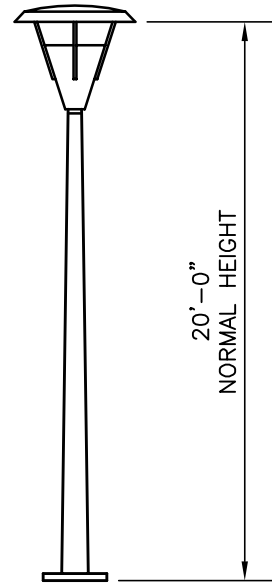

TYPE "B"

SYMBOLS

PROPOSED

EXISTING

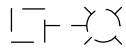
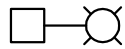

TYPE "A" ①



TYPE "B" ②



PULLBOX



CONDUIT



PEDESTAL & SERVICE CAN



UTILITY SERVICE PEDESTAL



WOOD POLE

① SHALL BE STEEL, ALUMINUM, OR EXPOSED AGGREGATE AS APPROVED BY DIRECTOR.

② SHALL BE PRESTRESSED EXPOSED AGGREGATE OR ALUMINUM POLES.

DRAWING APPROVED – CITY ENGINEER

<b>CITY OF ROCKLIN ENGINEERING DIVISION</b>	
STREET LIGHT POLES AND SYMBOLS	
SCALE: NONE DATE: DECEMBER 2015 DRAWN BY: J. PINKHAM	DWG # 7-9



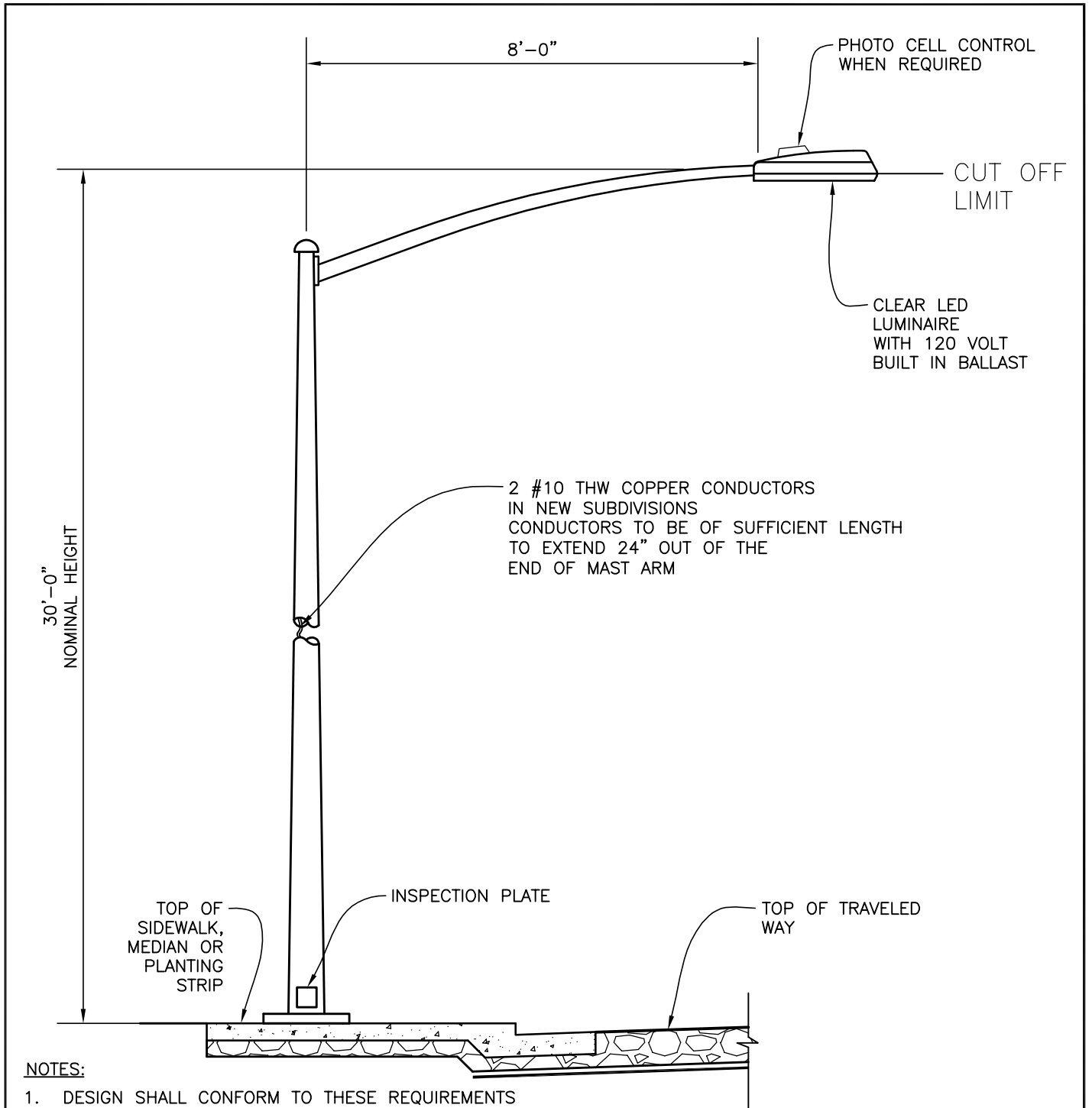

**NOTES:**

1. DESIGN SHALL CONFORM TO THESE REQUIREMENTS EXCEPT AS OTHERWISE APPROVED BY THE CITY ENGINEER BY VARIANCE.
2. FOR BASE DETAIL SEE CITY STANDARD DRAWING 7-4.
3. SEE CITY STANDARD DRAWING 7-3 FOR BASE LOCATION.

DRAWING APPROVED - CITY ENGINEER

<b>CITY OF ROCKLIN ENGINEERING DIVISION</b>	
TYPE "A" STREET LIGHTS FOR MAJOR STREETS AND COLLECTORS	
<b>SCALE: NONE</b>	<b>DWG #</b>
<b>DATE: DECEMBER 2015</b>	<b>7-10</b>
<b>DRAWN BY: J. PINKHAM</b>	

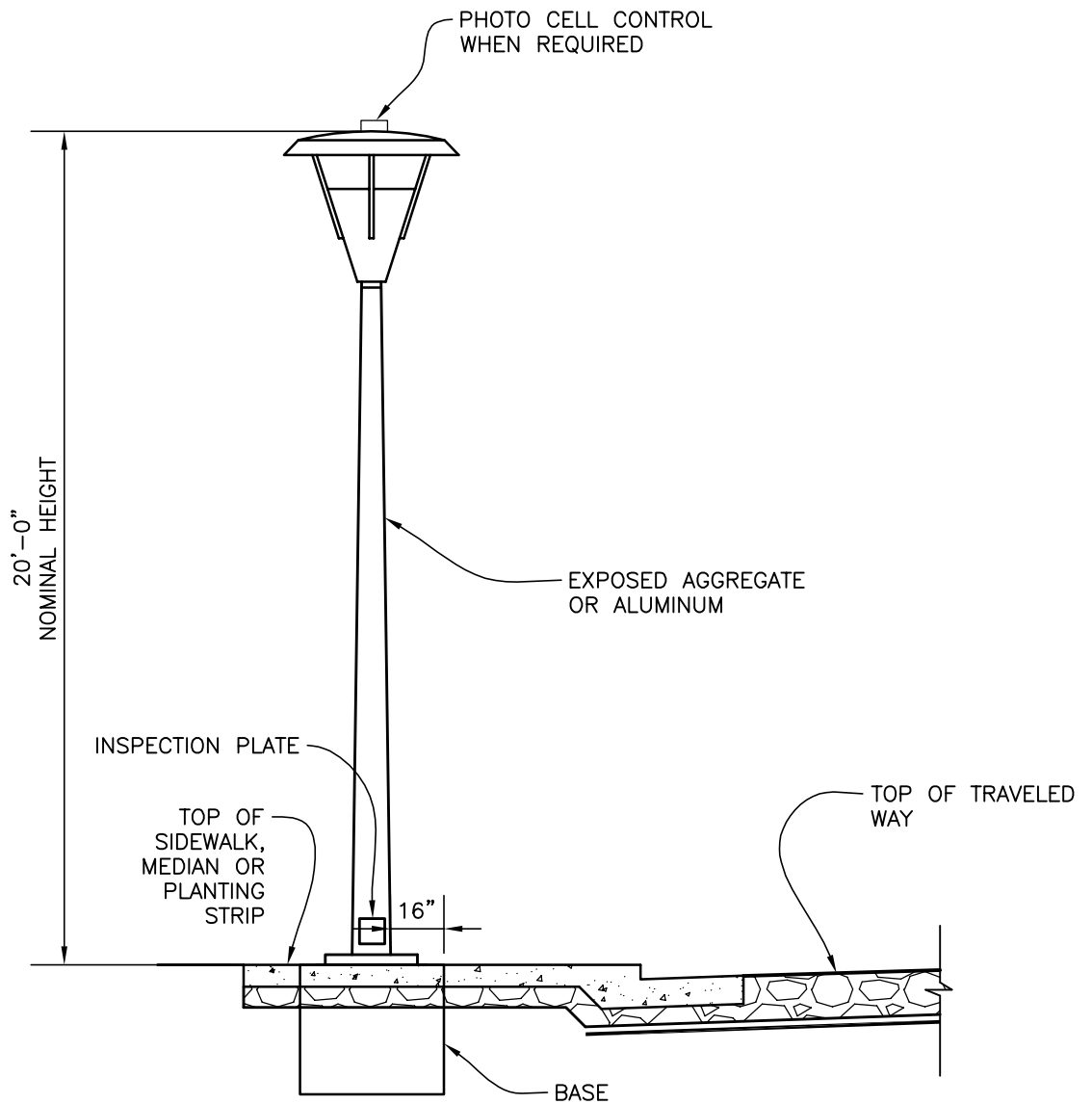

**NOTES:**

1. DESIGN SHALL CONFORM TO THESE REQUIREMENTS EXCEPT AS OTHERWISE APPROVED BY THE CITY ENGINEER BY VARIANCE.
2. FOR BASE DETAIL SEE CITY STANDARD DRAWING 7-4.
3. SEE CITY STANDARD DRAWING 7-3 FOR BASE LOCATION.

DRAWING APPROVED – CITY ENGINEER

<b>CITY OF ROCKLIN ENGINEERING DIVISION</b>	
TYPE "B" STREET LIGHTS FOR MINOR STREETS	
SCALE: NONE DATE: DECEMBER 2015 DRAWN BY: J. PINKHAM	<b>DWG #</b> 7-11

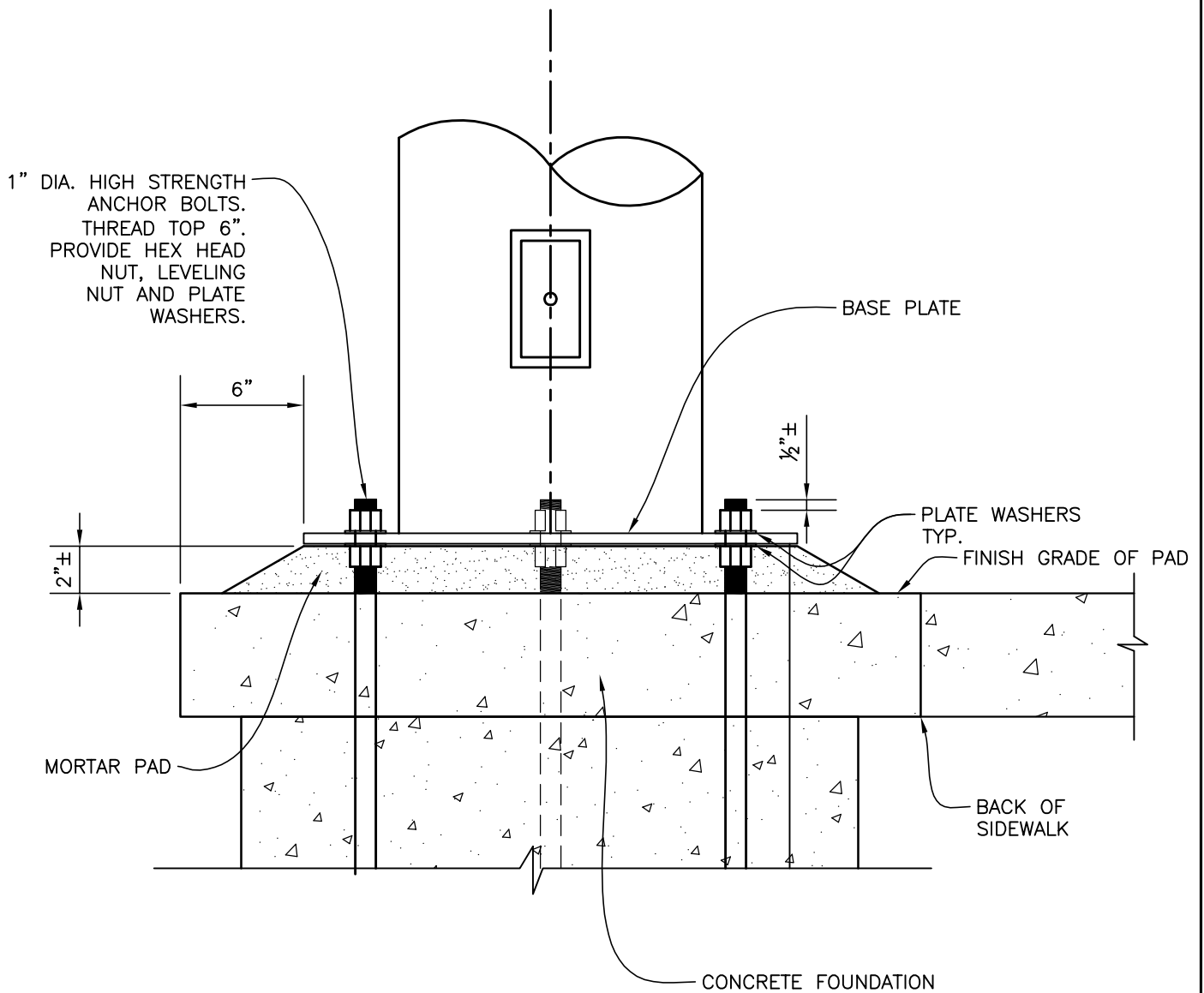

**NOTES:**

1. DESIGN SHALL CONFORMS TO THESE REQUIREMENTS EXCEPT AS OTHERWISE APPROVED BY THE CITY ENGINEER BY VARIANCE.
2. FOUNDATION BOLTS SHALL NOT BE CUT OFF FOR ANY REASON AND EXTENSION COUPLERS SHALL NOT BE PERMITTED.



DRAWING APPROVED – CITY ENGINEER

CITY OF ROCKLIN ENGINEERING DIVISION	
STREET LIGHT BASE LEVELING DETAIL	
SCALE: NONE	DWG #
DATE: DECEMBER 2015	7-12
DRAWN BY: J. PINKHAM	

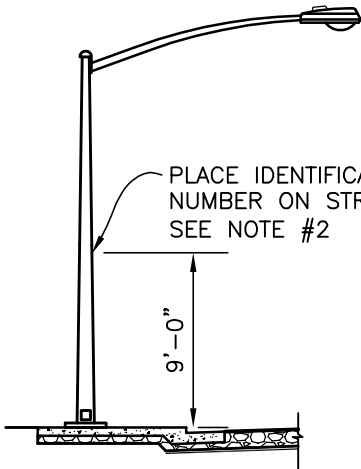

FIGURE 1  
SINGLE LUMINAIRE

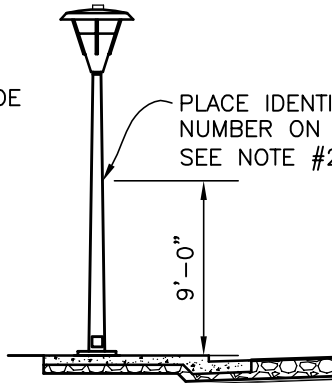

FIGURE 2  
POST TOP LUMINAIRE

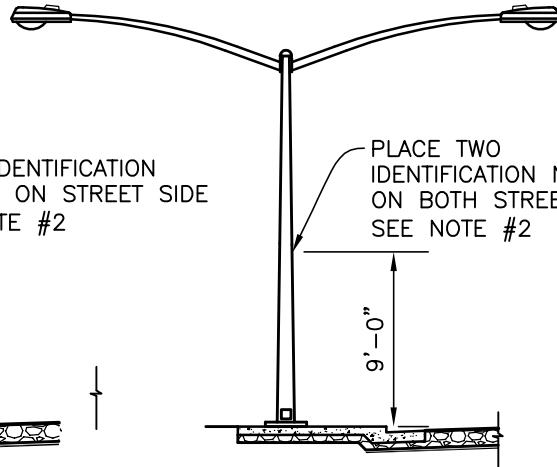

FIGURE 3  
TWIN LUMINAIRE

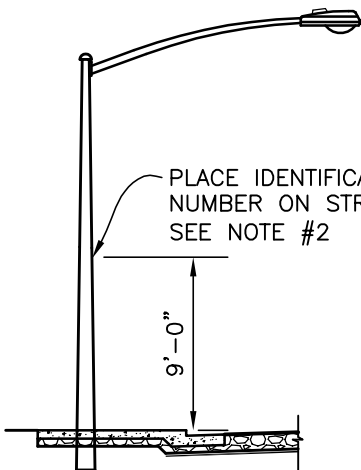

FIGURE 4  
LUMINAIRE ON WOOD  
STREET LIGHTING POLE

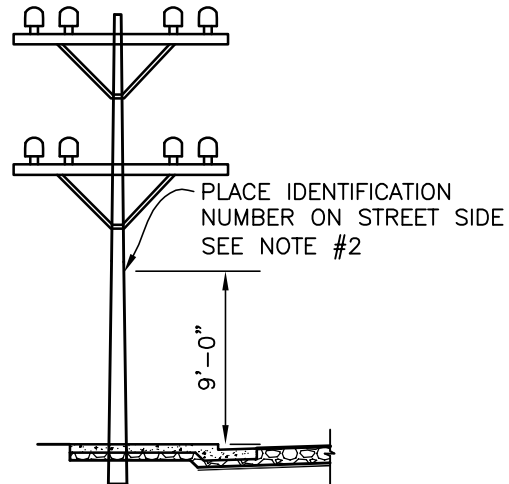

FIGURE 5  
LUMINAIRE ON  
DISTRIBUTION POLE

**NOTES:**

1. FIGURE 1, FIGURE 2 AND FIGURE 3 ARE METAL OR CONCRETE POLES OR POSTS.
2. IN THOSE INSTALLATIONS WHERE AESTHETICS ARE CONSIDERED IMPORTANT, THE IDENTIFICATION NUMBER MAY BE PLACED ON THE LOWER SIDE OF THE LUMINAIRE IN THE VICINITY OF THE 3"X3" LAMP IDENTIFICATION DECAL. ON POST TOP LUMINAIRES, IT MAY BE PUT ON THE BASE OF THE LUMINAIRE OR ON THE POLE BELOW THE LUMINAIRE.

DRAWING APPROVED - CITY ENGINEER

<b>CITY OF ROCKLIN ENGINEERING DIVISION</b>	
TYPICAL PLACEMENT OF IDENTIFICATION DECALS ON LUMINAIRE POLES	
<b>SCALE: NONE</b> <b>DATE: DECEMBER 2015</b> <b>DRAWN BY: J. PINKHAM</b>	<b>DWG #</b> <b>7-13</b>

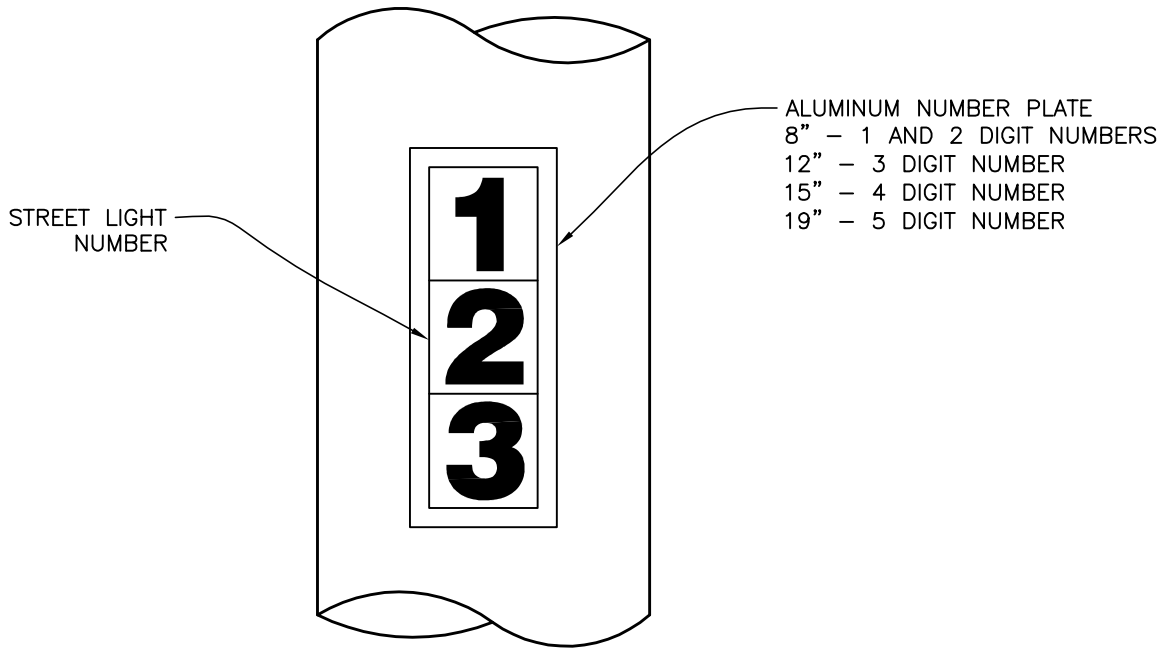

FIGURE 6  
 TYPICAL ARRANGEMENT OF NUMBERS ON POLE

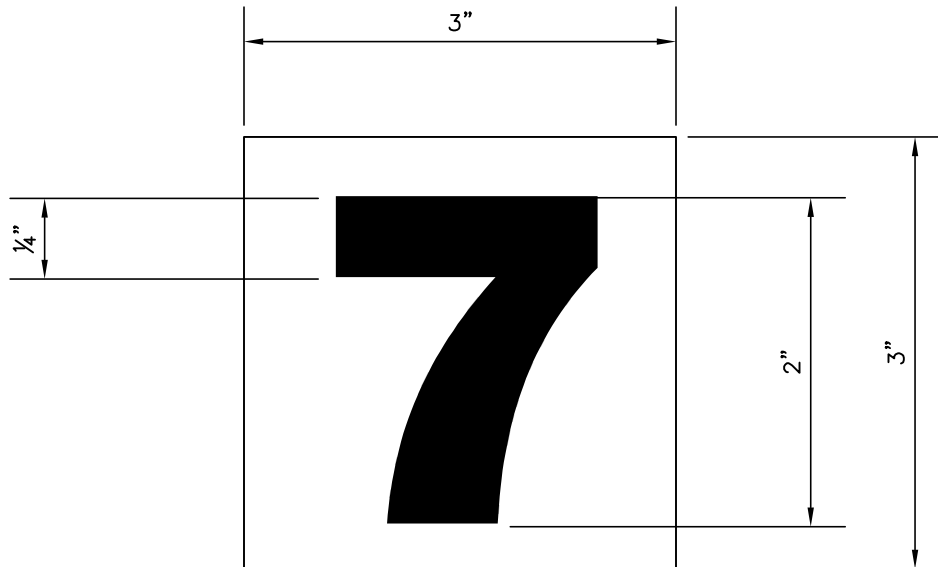

FIGURE 7

*[Signature]*  
 DRAWING APPROVED - CITY ENGINEER

CITY OF ROCKLIN ENGINEERING DIVISION	
STREET LIGHT IDENTIFICATION DECALS	
SCALE: NONE	DWG #
DATE: DECEMBER 2015	7-14
DRAWN BY: J. PINKHAM	

NOTES

1. INSTALLATION INSTRUCTIONS FOR REFLECTIVE NUMERALS AND LETTERS:
  - A. CLEAN AND THOROUGHLY DRY THE APPLICATION AREA.
  - B. PEEL BACKING PAPER OFF REFLECTIVE NUMERAL AND APPLY.
  - C. PRESS REFLECTIVE NUMERAL FIRMLY FROM CENTER OUTWARD TO REMOVE ANY ENTRAPPED AIR.
2. COLOR: BLACK NUMBERS AND LETTERS WITH A REFLECTIVE SILVER BACKGROUND.

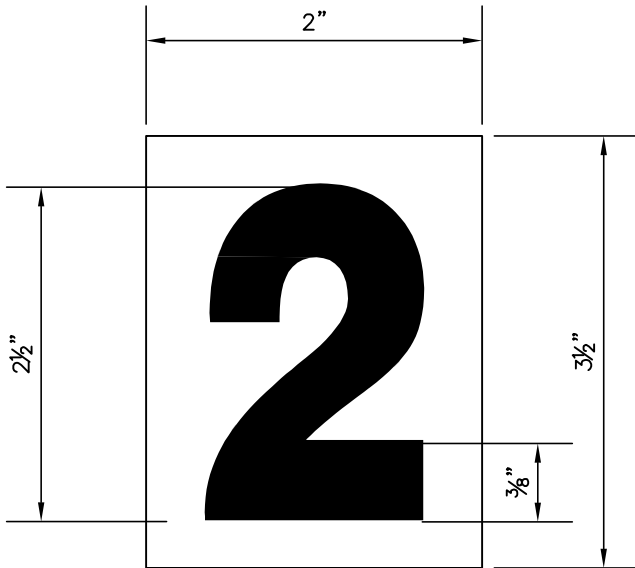

FIGURE 4  
SCOTCHLITE REFLECTIVE NUMERALS

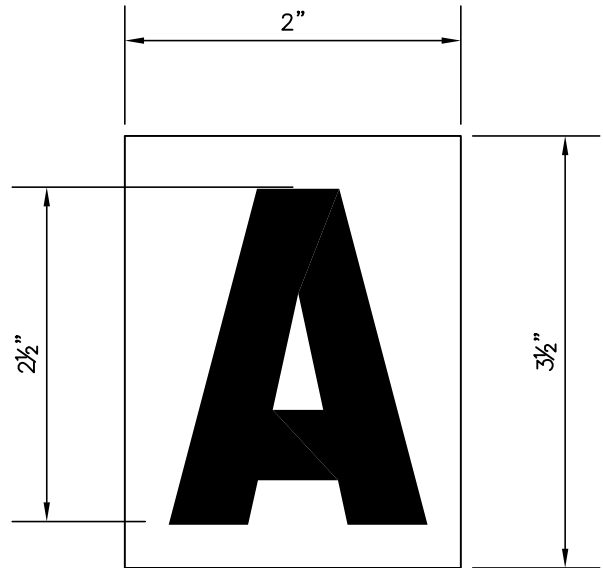
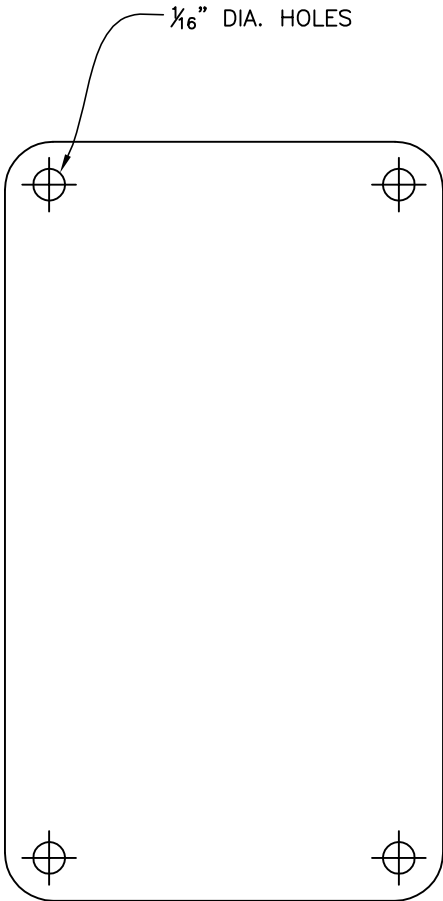

FIGURE 5  
SCOTCHLITE REFLECTIVE LETTERS

\_\_\_\_\_  
DRAWING APPROVED – CITY ENGINEER

CITY OF ROCKLIN ENGINEERING DIVISION	
REFLECTIVE NUMERALS AND LETTERS FOR STREET LIGHT MARKING	
SCALE: NONE	DWG #
DATE: DECEMBER 2015	7-15
DRAWN BY: J. PINKHAM	



TYPICAL ALUMINUM  
NUMBER PLATE

DIMENSIONS	COLOR
2 1/2" X 8" X .020	NON REFLECTIVE WHITE
2 1/2" X 12" X .020	
2 1/2" X 15" X .020	
2 1/2" X 19" X .020	
2 1/2" X 24" X .020	

DRAWING APPROVED – CITY ENGINEER

CITY OF ROCKLIN ENGINEERING DIVISION	
ALUMINUM NUMBER PLATES	
SCALE: NONE DATE: DECEMBER 2015 DRAWN BY: J. PINKHAM	DWG # 7-16

STREET CLASSIFICATION	ST. TYPE & R/W WIDTH	TYPE STREET LIGHT	NORMAL MOUNTING HEIGHT	AVERAGE MAINTAINED FOOTCANDLE	MAINTENANCE FACTOR
THOROUGHFARE	120'	A	30'	.70	.8
	90'	A	30'	.55	.8
ARTERIAL	80'	A	30'	.35	.8
COLLECTOR	66'	A	30'	.27	.8
	62'	A	20'	.16	.8
INDUSTRIAL COMMERCIAL	60'	A	30'	.24	.8
RESIDENTIAL	60'	B	20'	.13	.8
	50'	B	20'	.12	.8
	46'	B	20'	.11	.8
CUL-DE-SAC	42'	B	20'	.11	.8
PEDESTRIAN LANE	-	B	14'	.15	.8

1. LUMENS USED TO CALCULATE THE AVERAGE MAINTAINED FOOTCANDLE SHALL BE 80% OF INITIAL LUMEN VALUE RATED BY THE LAMP MANUFACTURER.

STREET CLASSIFICATION	ST. TYPE & R/W WIDTH	TYPE STREET LIGHT	NORMAL MOUNTING HEIGHT	LED WATTAGE	FRONT ON LOT	FRONT LOT OFF	LIGHT DISTRIBUTION PATTERN MIDBLOCK LOCATION
					SPACING (ONE SIDE ONLY)		
THOROUGHFARE	120'	A	30'	80/100 (SEE NOTE 4)	220	220	III
ARTERIAL	90'	A	30'	80	220	250	III
	80'	A	30'	80	SPACING (BOTH SIDES)		
COLLECTOR	66'	A	30'	80	180		III
	62'	A	30'	80	200		
INDUSTRIAL COMMERCIAL	60'	A	30'	80	220		III
RESIDENTIAL	60'	B	20'	55	200		III
	50'	B	20'	55	200		III
	46'	B	20'	55	240		III
CUL-DE-SAC	42'	B	20'	55	240		III

1. LAMP WATTAGE SHOWN IS FOR LED ONLY. DESIGN CRITERIA MUST BE SUBMITTED FOR ALL OTHER LAMPS
2. SPACING MAY BE ADJUSTED ±10% TO ALLOW FOR DRIVEWAYS.
3. BACK-ON LOT SPACING MAY BE ADJUSTED TO 330 FT. IF BOTH SIDES OF THE STREET ARE LIGHTED.
4. DECO VS ROADWAY (COBRA)



DRAWING APPROVED – CITY ENGINEER

**CITY OF ROCKLIN  
ENGINEERING DIVISION**

**STREET LIGHTING**

**DESIGN  
CRITERIA**

**SCALE: NONE**  
**DATE: DECEMBER 2015**  
**DRAWN BY: J. PINKHAM**

**DWG #**  
**7-17**



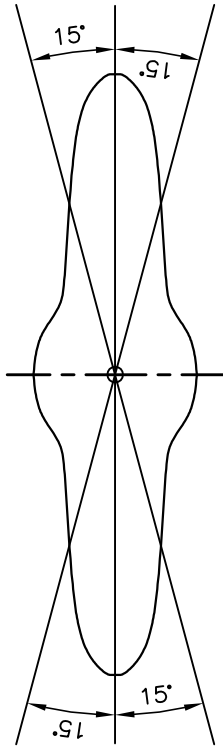

TYPE 1  
CENTER OF STREET

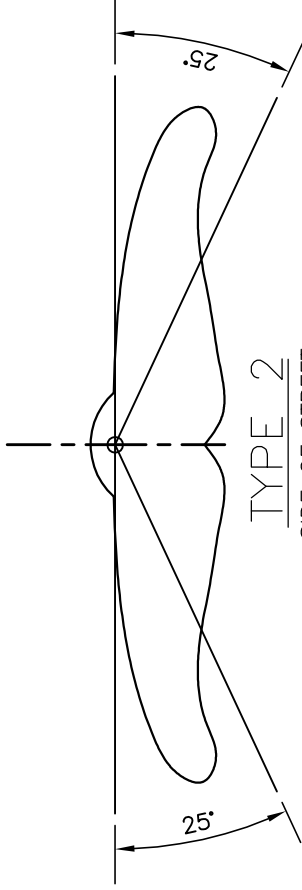

TYPE 2  
SIDE OF STREET

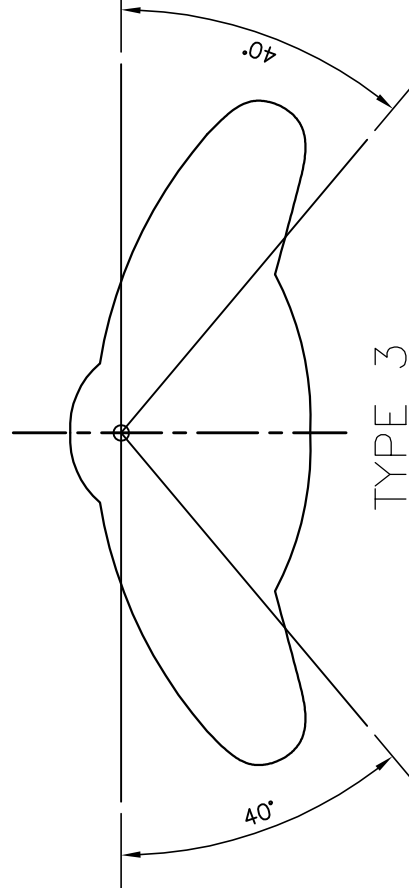

TYPE 3  
SIDE OF STREET

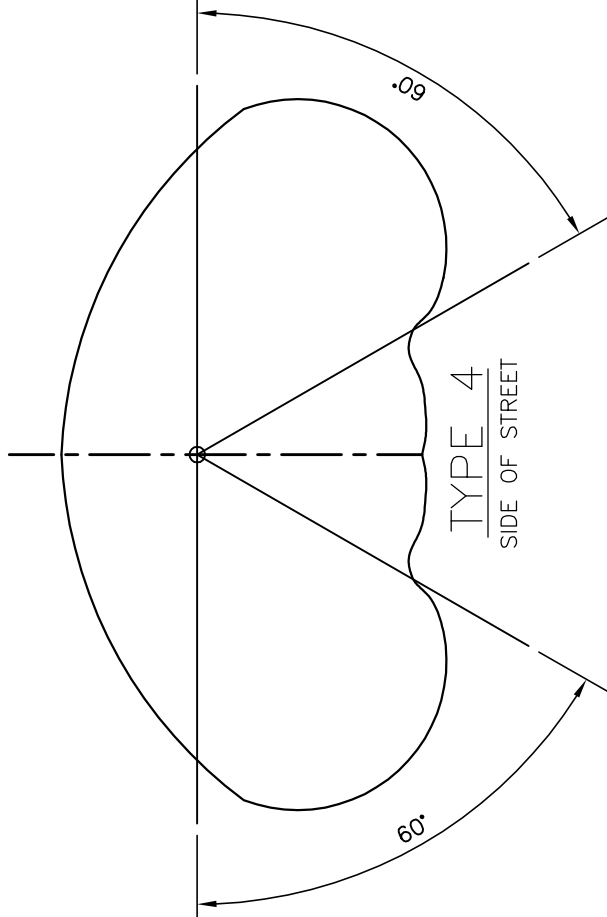

TYPE 4  
SIDE OF STREET

CITY OF ROCKKLIN  
ENGINEERING DIVISION

LATERAL

LIGHT  
DISTRIBUTION

SCALE: NONE

DATE: DECEMBER 2015

DRAWN BY: J. PINKHAM

DWG #

7-18

DRAWING APPROVED - CITY ENGINEER

# TYPICAL VOLTAGE DROP CALCULATION FOR 3-WIRE SYSTEM

$$\text{VOLTAGE DROP (COPPER CONDUCTOR)} = \frac{D \times A \times N \times 11}{\text{CIRCULAR MILS}}$$

D = LENGTH OF SECTION, IN FEET

A = LINE OPERATING AMPERES DRAWN BY ONE LIGHT

N = NUMBER OF LIGHTS IN THE CIRCUIT BEYOND THE SECTION

WIRE SIZE	AREA (CIRCULAR MILS)
14	4,110
12	6,530
10	10,380
8	16,510
6	26,250
4	41,740

LINE OPERATING AMPERES FOR LED LUMINAIRES	
55 WATTS .....	.39 AMPS
80 WATTS .....	.74 AMPS
101 WATTS .....	1.38 AMPS

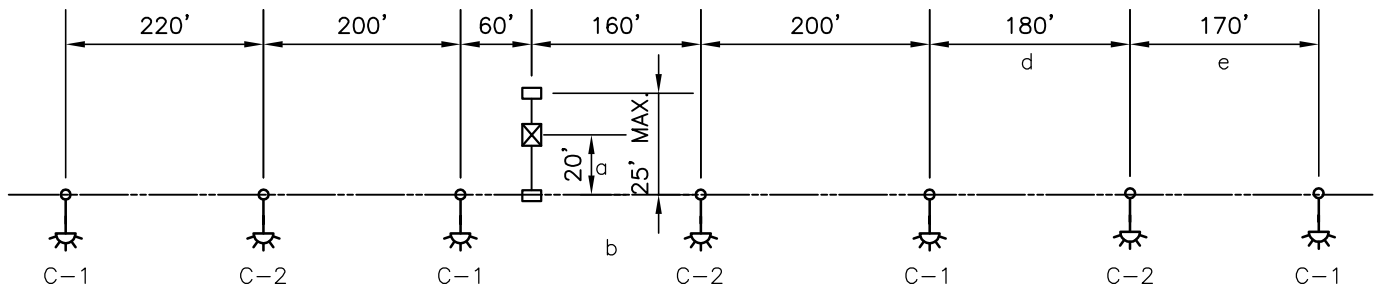

SAMPLE MULTIPLE STREET LIGHTING SYSTEM

## SAMPLE CALCULATION:





FIND TOTAL VOLTAGE DROP IN CIRCUIT #1  
(115 VOLT SYSTEM)

### VOLTAGE DROP CALCULATION:

$$\begin{aligned} \text{SECTION a} &= \frac{20 (2.9 \times 4) (11)}{6530} = 0.39 \\ \text{SECTION b + c} &= \frac{360 (2.9 \times 2) (11)}{6530} = 3.52 \\ \text{SECTION d + e} &= \frac{350 (2.9 \times 1) (11)}{6530} = 1.71 \\ \hline \text{TOTAL VOLTAGE DROP} &= 5.62 \end{aligned}$$

NOTE:  
MAXIMUM VOLTAGE DROP ALLOWED = 5% OR 6 VOLTS

## LEGEND

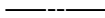
-  LED LUMINAIRE
-  C-1 CIRCUIT NUMBER
-  SERVICE CAN
-  PULL BOX
-  CONDUIT WITH #10 A.W.G. CONDUCTORS



DRAWING APPROVED - CITY ENGINEER

<b>CITY OF ROCKLIN ENGINEERING DIVISION</b>	
TYPICAL VOLTAGE DROP CALCULATION FOR 3-WIRE SYSTEM	
SCALE: NONE	DWG #
DATE: DECEMBER 2015	7-19
DRAWN BY: J. PINKHAM	

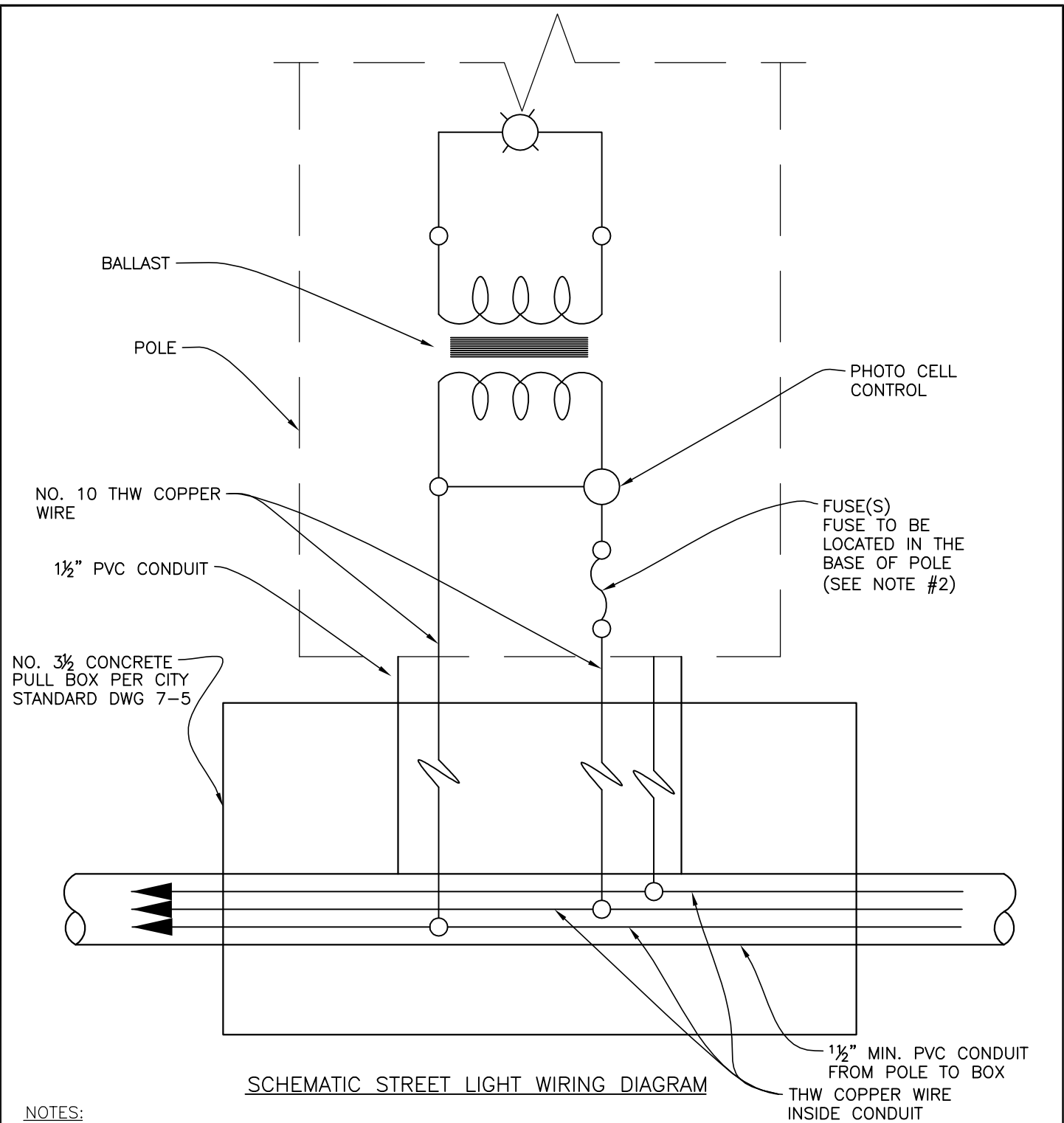

SCHEMATIC STREET LIGHT WIRING DIAGRAM

NOTES:

1. DESIGN SHALL CONFORM TO THESE REQUIREMENTS EXCEPT OTHERWISE APPROVED BY THE CITY ENGINEER.
2. FOR FUSING, NEC PRACTICES SHALL BE FOLLOWED. SEE MANUFACTURER SPECIFICATIONS FOR FUSING REQUIREMENTS.

DRAWING APPROVED – CITY ENGINEER

<b>CITY OF ROCKLIN ENGINEERING DIVISION</b>	
STREET LIGHT STANDARD WIRING DIAGRAM	
SCALE: NONE	DWG #
DATE: DECEMBER 2015	7-20
DRAWN BY: J. PINKHAM	

**SERVICE ENCLOSURE WIRING DIAGRAM**

METERED PER UTILITY REQUIREMENTS

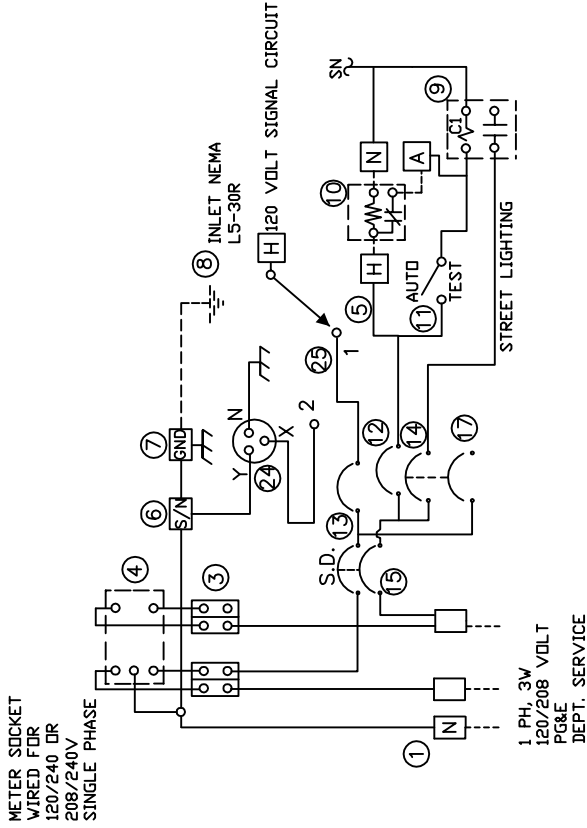

1 PH, 3W  
120/208 VOLT  
PG&E  
DEPT. SERVICE

*[Signature]*  
DRAWING APPROVED - CITY ENGINEER

*[Signature]*

DRAWING APPROVED - DIRECTOR OF PUBLIC SERVICES

CITY OF ROCKLIN ENGINEERING DIVISION	
TYPICAL SERVICE AND WIRING SCHEDULE	
SCALE: NONE	DWG # 8-1
DATE: AUGUST 2015	
DRAWN BY: J. PINKHAM	

COMPONENT	NAME PLATE DESCRIPTION
①	NEUTRAL LUG
②	LANDING LUG
③	TEST BYPASS FACILITIES
④	METER SOCKET AND SUPPORT
⑤	TERMINAL BLOCKS
⑥	SOLID NEUTRAL BUS
⑦	GROUND BUS
⑧	GROUND ROD
⑨	35A MERCURY CONTACTOR
⑩	PHOTO ELECTRIC UNIT
⑪	15 AMP SWITCH SPST
⑫	15A, 120V, 1P, CKT. BKR.
⑬	50A, 120V, 1P, CKT. BKR.
⑭	20A, 240V, 1P, CKT. BKR.
⑮	100A, 240V, 2P, CKT. BKR.
⑯	20A, 120V, 1P, CKT. BKR.
⑰	50A, 120V, FLANGED RECEPTACLE
⑱	55A, 120V, 1P
	TRANSFER SWITCH



**POLE & EQUIPMENT SCHEDULE**

NO.	STANDARD		VEHICLE SIGNAL MOUNTING	PEDESTRIAN SIGNAL MOUNTING	LED LUMINAIRE WATTAGE @20 VOLT	NOTES
	TYPE	SIG. MA LUM. MA (FEET)				
(A)	26-4-70	40'	MAS-xx MAS-xx	SV-1-T SP-2-CS	2 8	
(B)	1-B			TV-2-T SP-2-CS		
(C)	18-3-70	30'	MAS-xx	SP-1-CS		
(D)	1-B			TV-2-T		
(E)	18-3-70	25'	MAS-xx	SV-1-T SP-1-CS		
(F)	1-B			TV-1-T	2	
(G)	TYPE 15	15'				

61-5-129 \*

xx = DISTANCE FROM SHAFT TO SIGNAL HEADS.  
 \* CONTRACTOR SHALL PROVIDE TO THE CITY: ENGINEERING CALCULATIONS FROM THE POLE MANUFACTURER FOR LOADING CONDITIONS IF NOT ALREADY ON FILE WITH THE CITY.

<b>CITY OF ROCKLIN ENGINEERING DIVISION</b>	
TYPICAL POLE AND EQUIPMENT SCHEDULE	
SCALE: NONE	DWG #
DATE: DECEMBER 2015	8-2
DRAWN BY: J. PINKHAM	

  
 DRAWING APPROVED - CITY ENGINEER  
  
 DRAWING APPROVED - DIRECTOR OF PUBLIC SERVICES

		CONDUCTOR SCHEDULE										
AWG	CIRCUIT	1	2	3	4	5	6	7	8	9	10	11
No. 14	Ø1	3	3	3	3	3	3	3	3	3	6	6
	Ø2						6	6	3	9		
	Ø3			3	3	3					12	
	Ø4			3	3	9					12	
	Ø5					3	3	6			6	
	Ø6	6	6	6	6	9					9	
	Ø7											
	Ø8											
	Ø2 PED						2	2	2	4		
	Ø4 PED				2	2		4			4	
	Ø6 PED	2	2	2	4	4					4	
	Ø8 PED											
	Ø2 PPB								1	1	2	
	Ø4 PPB					1	1	2	2		2	
Ø6 PPB	1	1	2	2						2		
Ø8 PPB												
SPARES	6	12	12	15	21	6	33	6	42			
P.E.U.										2		
TOTAL No.14		17	30	30	44	57	18	57	15	116		
No.12	PPB COMMON	1	1	1	1	1	2	1	2			
No.10	LUMINAIRE	2	2	2	2	2	2	2	2			
No. 8	SIGNAL COMMON	1	1	1	1	1	1	2	1	2		
No.10	PULL WIRE	1	1	1	1	1	1	1	1	1		
No.10	ILL. STREET LIGHT											
DLC	Ø1 DETECTORS					4		4			4	
	Ø2 DETECTORS									12	12	
	Ø3 DETECTORS			7	7	7		7			7	
	Ø4 DETECTORS							9			9	
	Ø5 DETECTORS									4	4	
	Ø6 DETECTORS					11		11			11	
	Ø7 DETECTORS											
	Ø8 DETECTORS											
TOTAL DLC			7	7	22		31	16	47			
OPTICALS	IC CABLE											
	EVA						1	1		1		
	EVB				1	1		1		1		
	EVC	1	1	1	1	1		1		1		
	EVD										1	
TOTAL CABLES	1	1	1	2	2	1	3	4				
TOTAL CONDUCTORS												
CONDUCTOR SIZES		3"	2.5"	3"	1.5"	3"	3"	2.5"				
PERCENT FILL												

PT2 CCTV WIFI CABLE  
PT2 CCTV POWER CABLE \*

- + PROVIDE 1 #10 GREEN PULLWIRE IN EACH CONDUIT
- ⊙ FURNISH AND INSTALL COMMSCOPE ULTRA 11 ENHANCED CAT 5E CABLE, PART NUMBER 5NF4-4 TWISTED PAIR FLOODED CABLE OR APPROVED EQUAL.
- \* FURNISH AND INSTALL IMSA-14-3/20-/-STR CAMERA POWER CABLE. CABLE SHALL BE 600 VOLT AND 90 DEGREE C. COLOR CODE 3/C: BLACK, WHITE AND GREEN (BELDEN PN601195 OR CITY APPROVED EQUAL.)



DRAWING APPROVED -- CITY ENGINEER



DRAWING APPROVED -- DIRECTOR OF PUBLIC SERVICES

CITY OF ROCKLIN ENGINEERING DIVISION	
TYPICAL CONDUCTOR SCHEDULE	
SCALE: NONE	DWG # 8-3
DATE: AUGUST 2015	DRAWN BY: J. PINKHAM

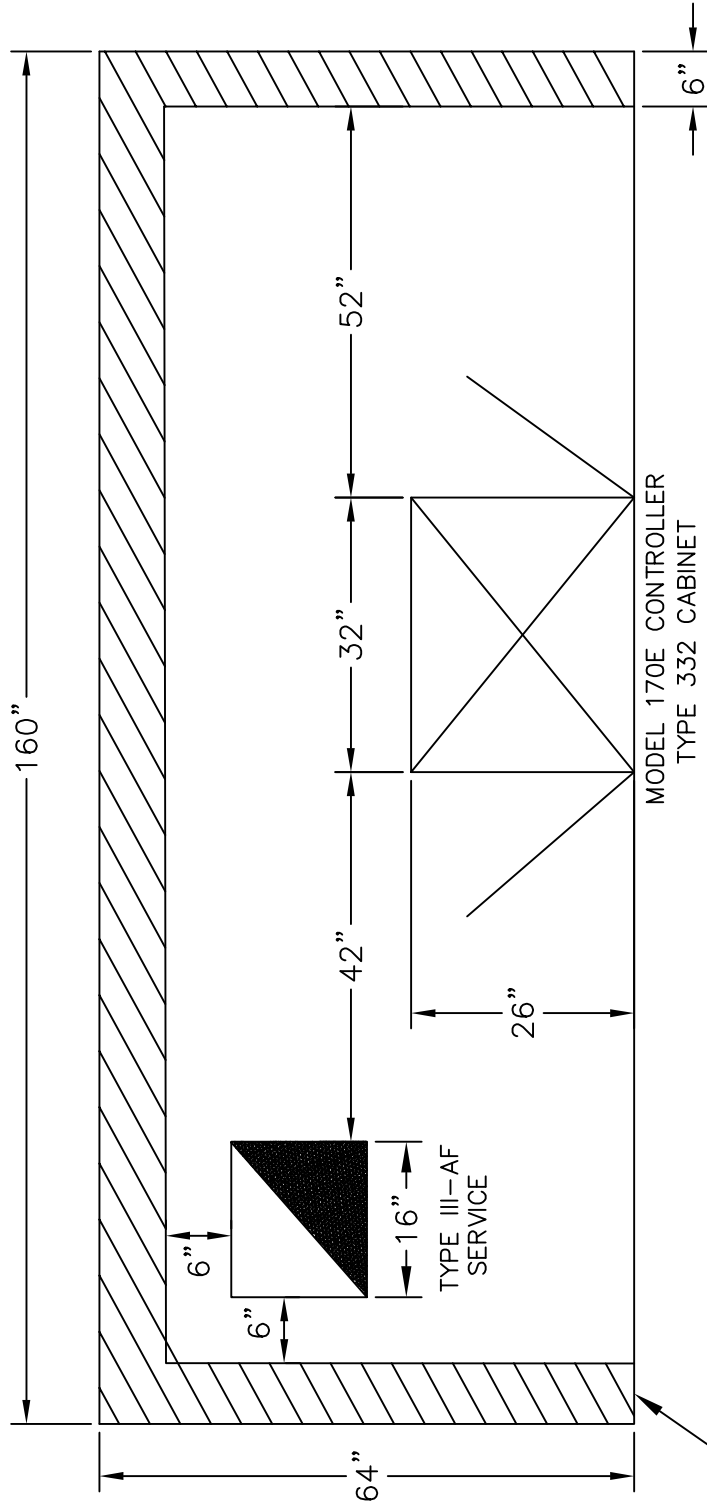

RETAINING CURB:

6" WIDTH W/ 6" MIN. HEIGHT  
 DEPENDING ON SLOPE TO THE BACK.  
 CURB TO BE DOWELED TO THE PAD  
 AT 24" CENTERS, OR MAY BE  
 POURED MONOLITHICALLY WITH PAD.  
 INSTALL 1/ #4 HORIZONTAL REBAR  
 THE FULL LENGTH OF THE CURB.

MINOR CONCRETE

MODEL 170E CONTROLLER  
 TYPE 332 CABINET  
 ROADWAY/SIDEWALK SIDE

*[Signature]*

DRAWING APPROVED - CITY ENGINEER

*[Signature]*

DRAWING APPROVED - DIRECTOR OF PUBLIC SERVICES

CITY OF ROCKLIN  
 ENGINEERING DIVISION

TYPICAL CONTROLLER/  
 SERVICE CABINET DETAIL

SCALE: NONE	DWG #
DATE: AUGUST 2015	8-4
DRAWN BY: J. PINKHAM	

\* DISTANCE OF ADVANCE LOOPS TO BE DECIDED USING CA MUTCD TABLE 4D-101 (CA) 85th PERCENTILE SPEED.

\* CENTER LOOPS IN EFFECTIVE AREA.  
 \* HANDHOLES TO BE PLACED BETWEEN NUMBER 2 AND 3 LOOPS IN THE THROUGH LANES.

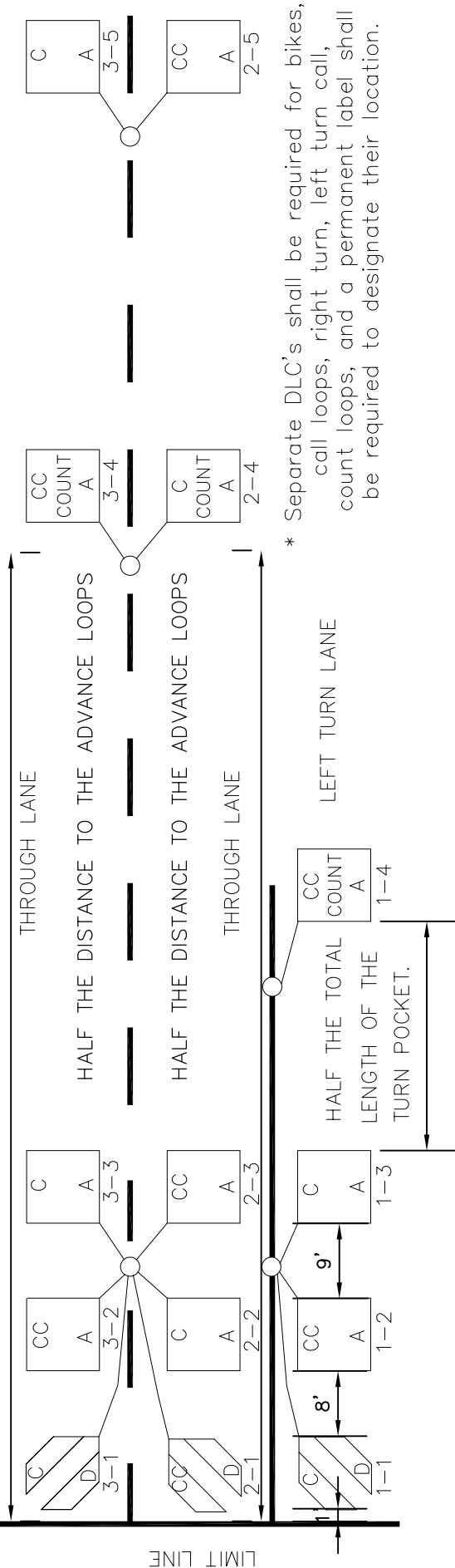
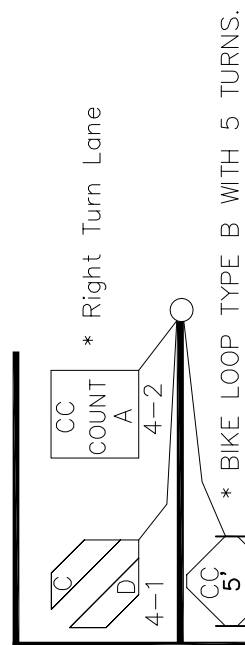

\* Separate DLC's shall be required for bikes, call loops, right turn, left turn call, count loops, and a permanent label shall be required to designate their location.

*[Signature]*  
 DRAWING APPROVED - CITY ENGINEER

CITY OF ROCKLIN  
 ENGINEERING DIVISION  
 TYPICAL LOOP DETECTOR  
 LAYOUT

SCALE: NONE  
 DATE: AUGUST 2015  
 DRAWN BY: J. PINKHAM  
 DWG # 8-5

LEGEND

- A= TYPE "A" LOOP
- B= TYPE "B" LOOP
- D= TYPE "D" LOOP
- C= CLOCKWISE WOUND LOOP
- CC= COUNTER CLOCKWISE WOUND LOOP
- 1-1= LANE # , LOOP#
- COUNT= COUNT LOOP

LOOP DETECTOR ASSIGNMENTS

	(1)	(2)	(3)
	THRU	THRU	THRU
CALL	111L 315U 5J1U 7J5U	214U 418U 6J4U 8J8U	214L 418L 6J4L 8J8L
COUNT	119U* 319L* 5J9U* 7J9L*	213U 417U 6J3U 8J7U	212L 416U 6J2L 8J6L
ADVANCE		213L 417L 6J3L 8J7L	



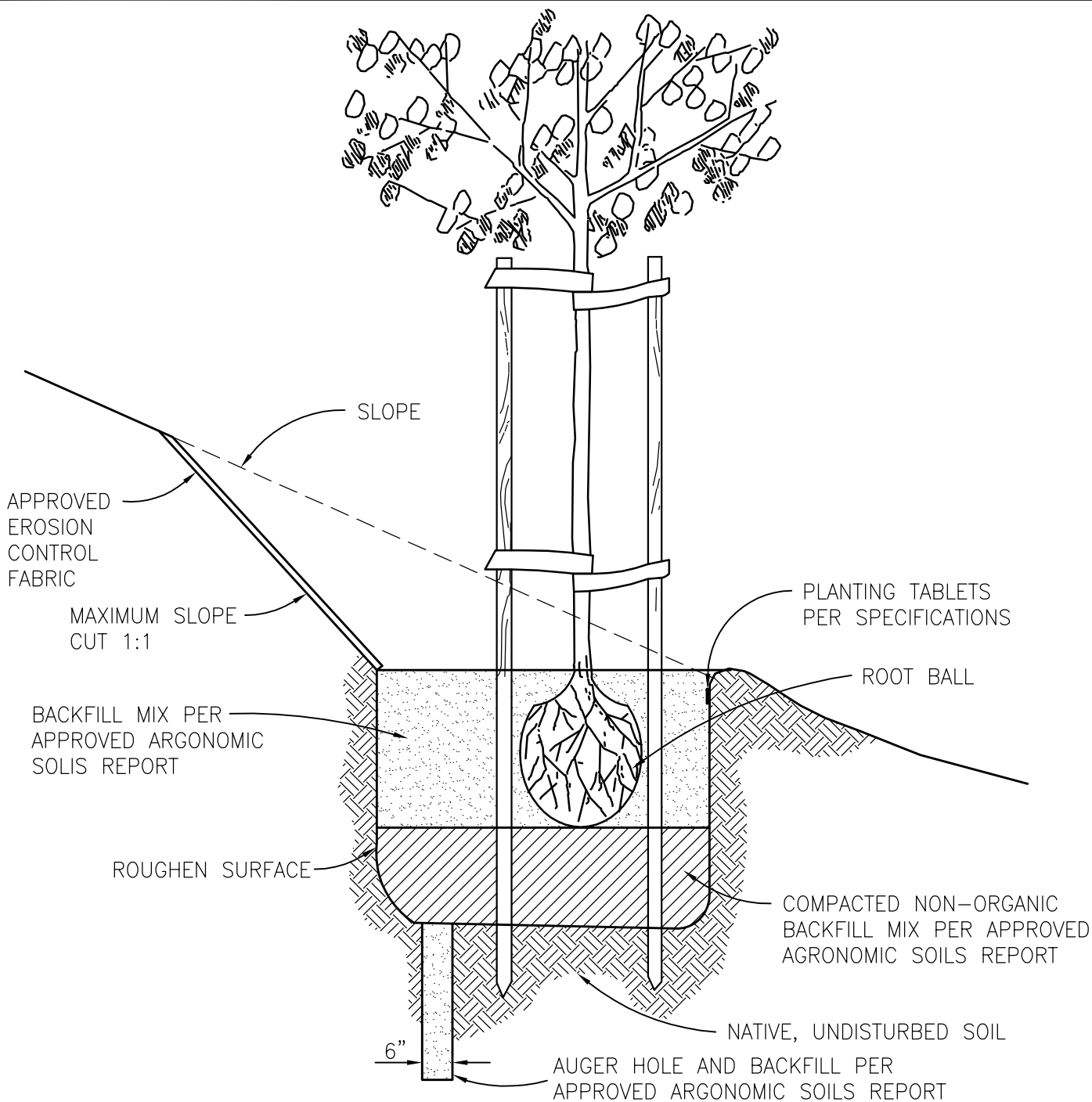

**NOTES:**

1. BACKFILL MATERIAL SHALL NOT HAVE PARTICLES GREATER THAN 1/2".
2. PLANT PIT TO BE EXCAVATED TO 1-1/2 TIMES THE ORIGINAL CONTAINER DEPTH AND 2 TIMES THE DIAMETER OF ORIGINAL CONTAINER.
3. DOUBLE STAKE ALL TREES 15 GALLON SIZE AND LARGER UNLESS DIRECTED OTHERWISE BY CITY ARBORIST OR ENGINEER.
4. DOUBLE STAKES SHALL USE STEEL TWIST BRACE.
5. TREES SHALL NOT BE PLACED WITHIN 100' OF A STOP SIGN OR TRAFFIC SIGNAL.

*[Handwritten signature]*

DRAWING APPROVED – DIRECTOR OF PUBLIC SERVICES

<b>CITY OF ROCKLIN ENGINEERING DIVISION</b>	
<b>SLOPE PLANTING</b>	
<b>SCALE: NONE</b>	<b>DWG #</b>
<b>DATE: DECEMBER 2015</b>	<b>9-1</b>
<b>DRAWN BY: J. PINKHAM</b>	

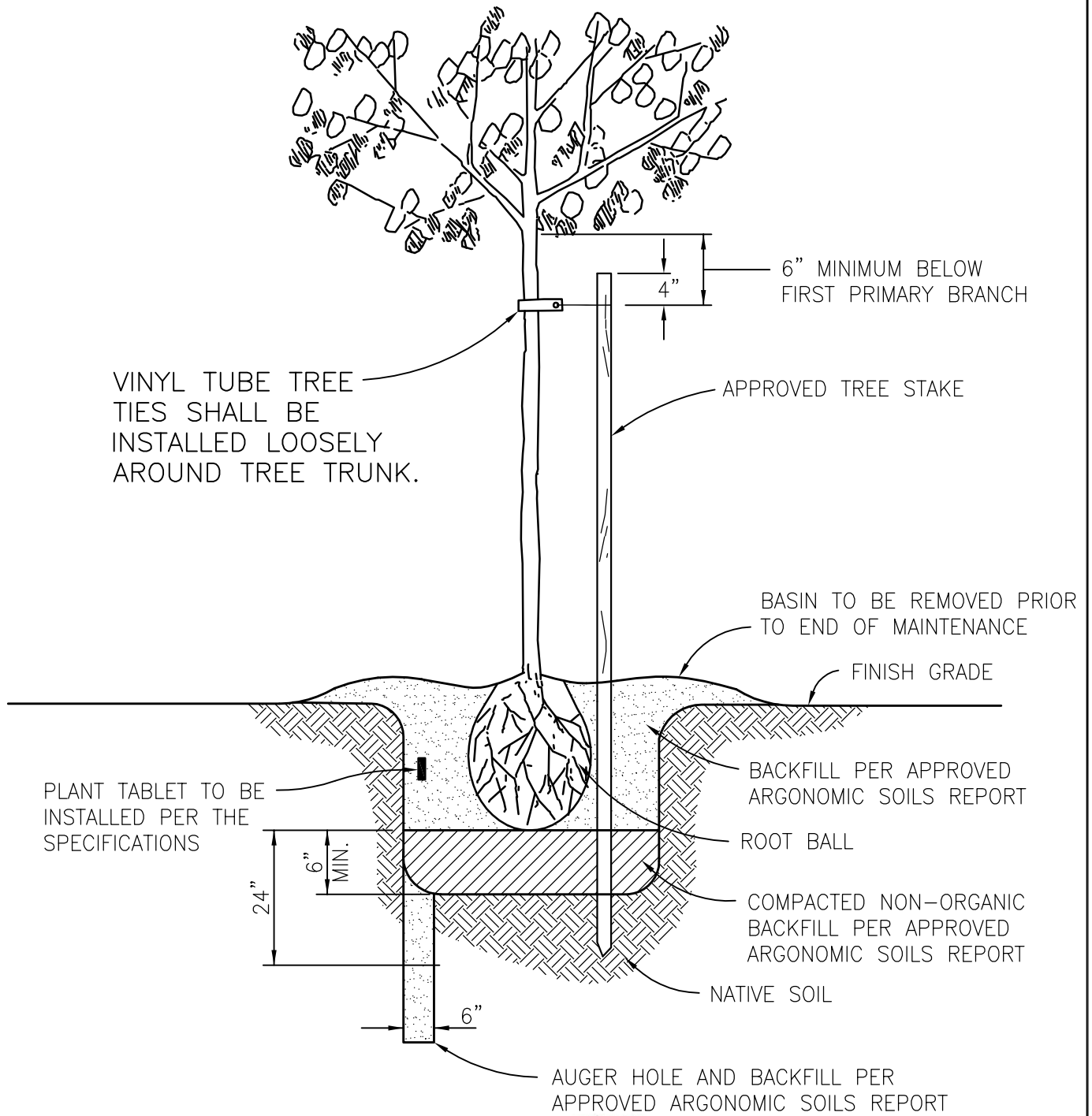

*J. Pinkham*

NOTES:

1. BACKFILL MATERIAL SHALL NOT HAVE PARTICLE SIZES GREATER THAN 1/2".
2. PLANT PIT SHALL BE EXCAVATED TO 1-1/2 TIMES THE DEPTH AND 2 TIMES THE DIAMETER OF THE ORIGINAL CONTAINER.
3. SINGLE STAKE ALL TREES SMALLER THAN 15 GALLON SIZE ONLY.

DRAWING APPROVED – DIRECTOR OF PUBLIC SERVICES

<b>CITY OF ROCKLIN ENGINEERING DIVISION</b>	
TREE PLANTING – SINGLE STAKE	
SCALE: NONE	DWG #
DATE: DECEMBER 2015	9-2
DRAWN BY: J. PINKHAM	

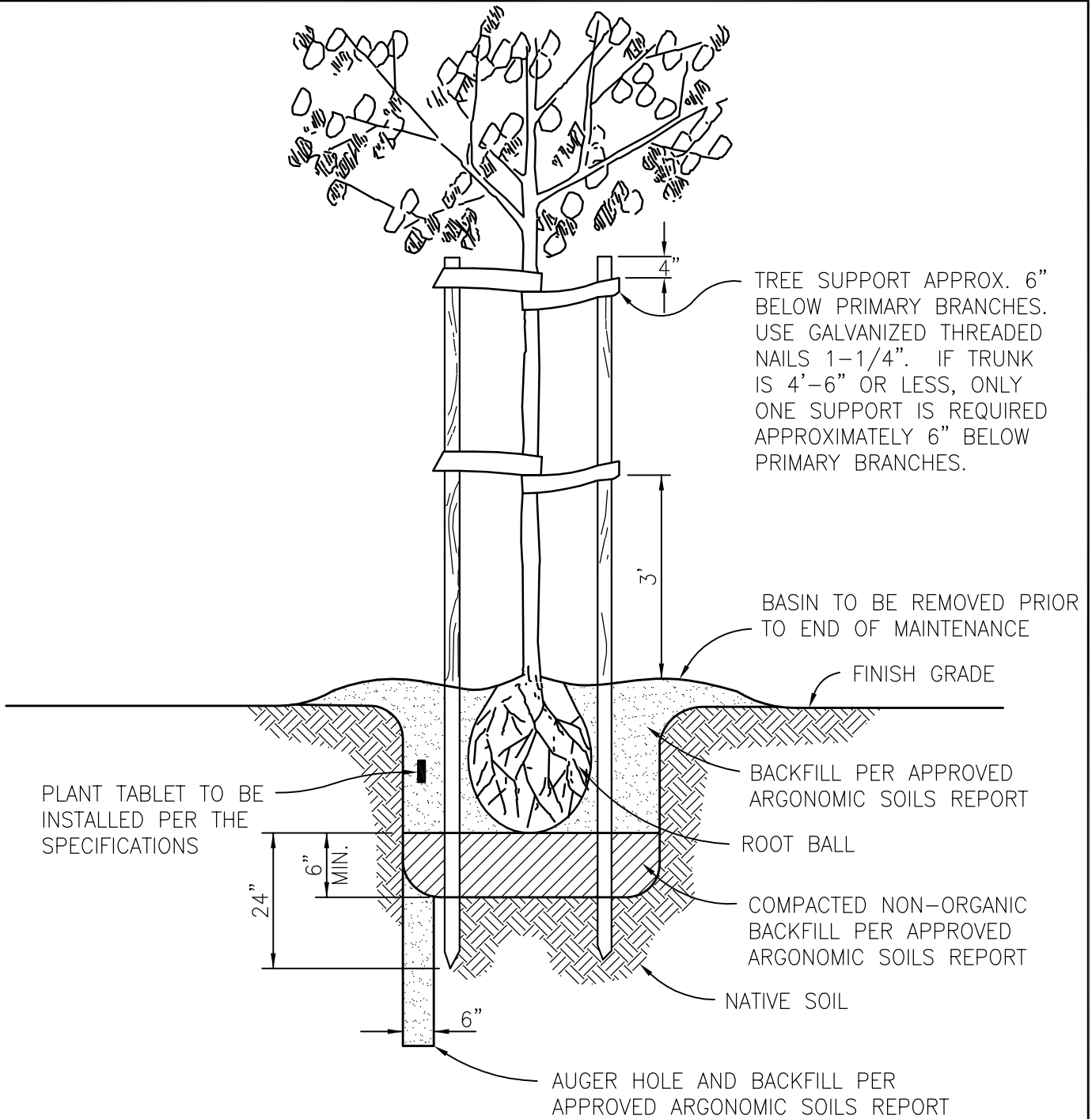

**NOTES:**

1. BACKFILL MATERIAL SHALL NOT HAVE PARTICLE SIZES GREATER THAN 1/2".
2. PLANT PIT SHALL BE EXCAVATED TO 1-1/2 TIMES THE DEPTH AND 2 TIMES THE DIAMETER OF THE ORIGINAL CONTAINER.
3. DOUBLE STAKE ALL TREES 15 GALLON SIZE AND LARGER UNLESS DIRECTED OTHERWISE BY CITY ARBORIST OR ENGINEER.
4. DOUBLE STAKE SHALL USE STEEL TWIST BRACE.

DRAWING APPROVED – DIRECTOR OF PUBLIC SERVICES

<b>CITY OF ROCKLIN ENGINEERING DIVISION</b>	
<b>TREE PLANTING – DOUBLE STAKE</b>	
<b>SCALE: NONE</b>	<b>DWG #</b>
<b>DATE: DECEMBER 2015</b>	<b>9-3</b>
<b>DRAWN BY: J. PINKHAM</b>	

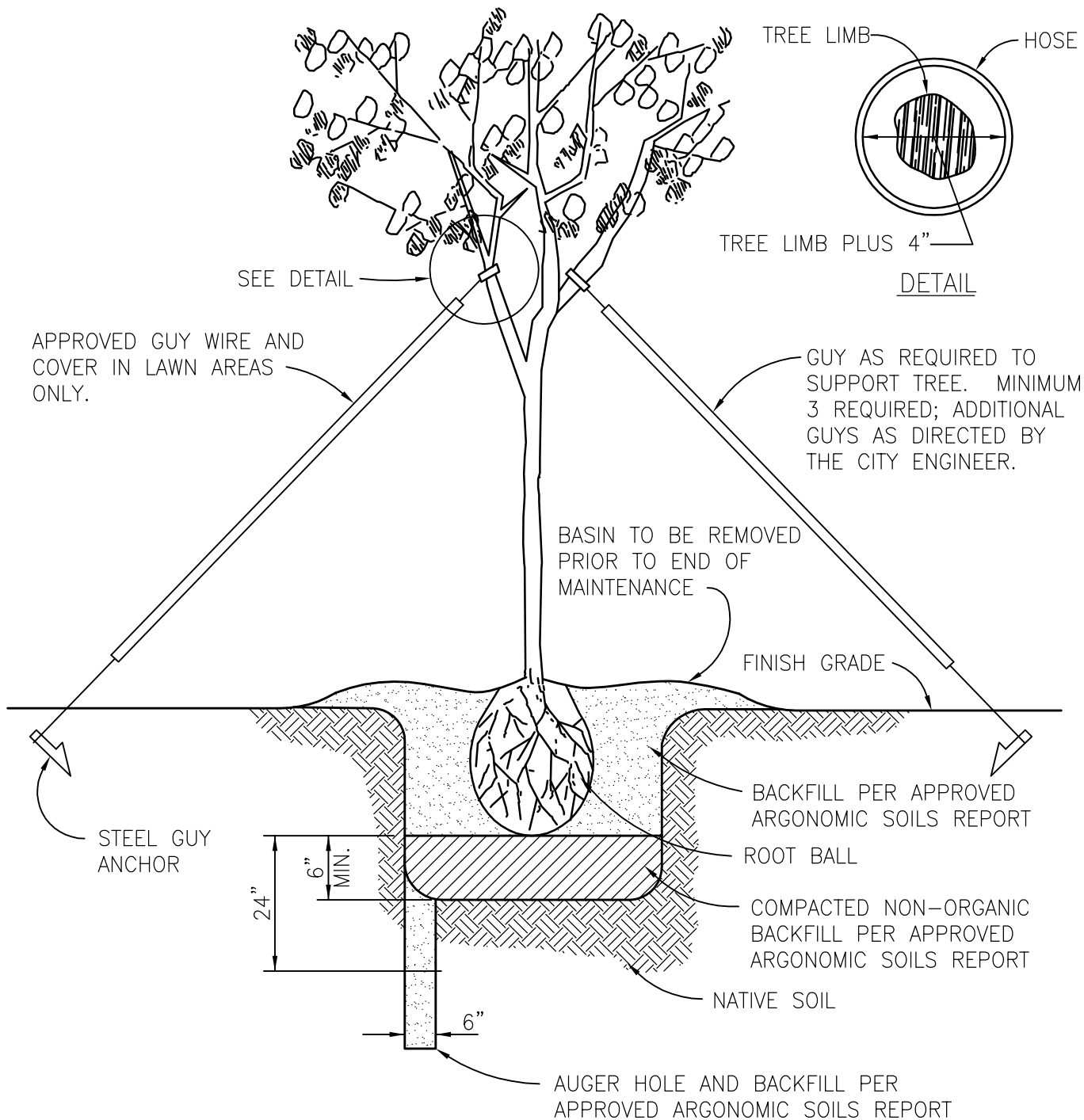

*[Handwritten Signature]*

**NOTES:**

1. GUYING OF TREES MUST RECEIVE PRIOR APPROVAL BY THE CITY ENGINEER.
2. PLANT PIT SHALL BE EXCAVATED TO 1-1/2 TIMES THE DEPTH AND 2 TIMES THE DIAMETER OF THE ORIGINAL CONTAINER.
3. PLANTING TABLETS SHALL BE INSTALLED PER THE SPECIFICATION.

DRAWING APPROVED — DIRECTOR OF PUBLIC SERVICES

<b>CITY OF ROCKLIN ENGINEERING DIVISION</b>	
<b>TREE GUYING</b>	
<b>SCALE: NONE</b> <b>DATE: DECEMBER 2015</b> <b>DRAWN BY: J. PINKHAM</b>	<b>DWG #</b> <b>9-4</b>

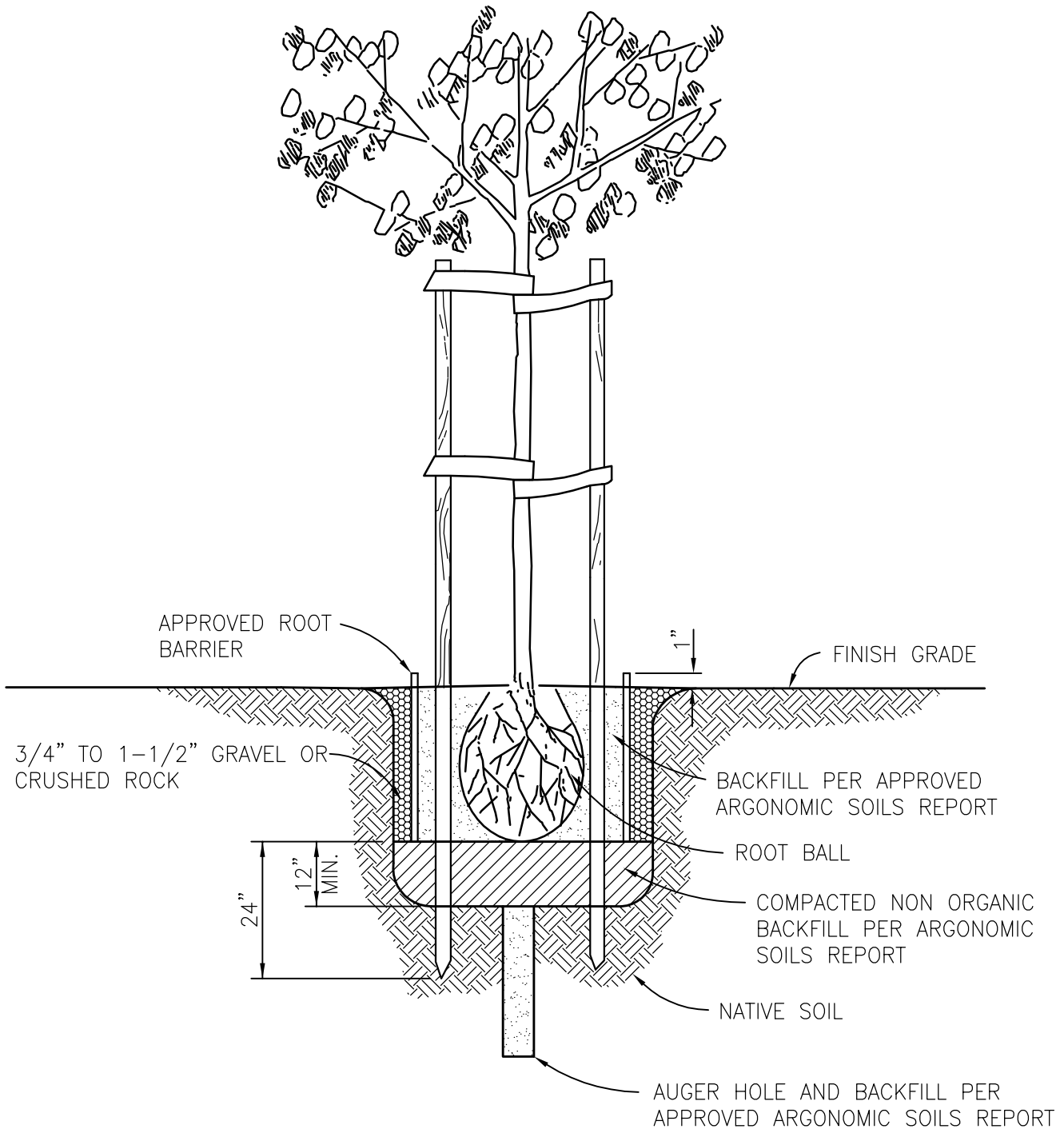

NOTE:  
 1) DOUBLE STAKE SHALL USE STEEL TWIST BRACE.

DRAWING APPROVED – DIRECTOR OF PUBLIC SERVICES

<b>CITY OF ROCKLIN          ENGINEERING DIVISION</b>	
<b>ROOT          BARRIER PLANTER          BOX</b>	
<b>SCALE: NONE</b> <b>DATE: DECEMBER 2015</b> <b>DRAWN BY: J. PINKHAM</b>	<b>DWG #</b> <b>9-5</b>

PLANTING DEPTH:  
TOP OF ROOT BALL  
1" ABOVE FINISH  
GRADE. PLANT NO  
DEEPER THAN GROWN  
IN NURSERY.

PIT SIZE:  
TWICE AS WIDE  
AND 1'-0" DEEPER  
THAN THE ROOT  
BALL.

ROOT BALL

PIT BOTTOM:  
RAISE SLIGHTLY FOR  
PROPER DRAINAGE.  
LOOSEN SUBSOIL AT  
BOTTOM OF HOLE  
WITH A PICK.

1/2" DEPTH MULCH

EARTH SAUCER:  
INNER DIAMETER AS  
WIDE AS ROOT BALL

FINISH  
GRADE

4"

PLANTING TABLET

PLANTING MIXTURE:  
PROVIDE SPECIFICATIONS  
FOR BACKFILL.  
CROWN THEN FIRM  
TO REDUCE SETTLING.

- PROVIDE CITY WITH PLANTING MIXTURE SPECIFICATIONS
- PLANTER AREA SHOULD HAVE PRE-EMERGENT HERBICIDE APPLIED BEFORE PLANTING TO PREVENT GERMINATION OF WEED SEEDS.

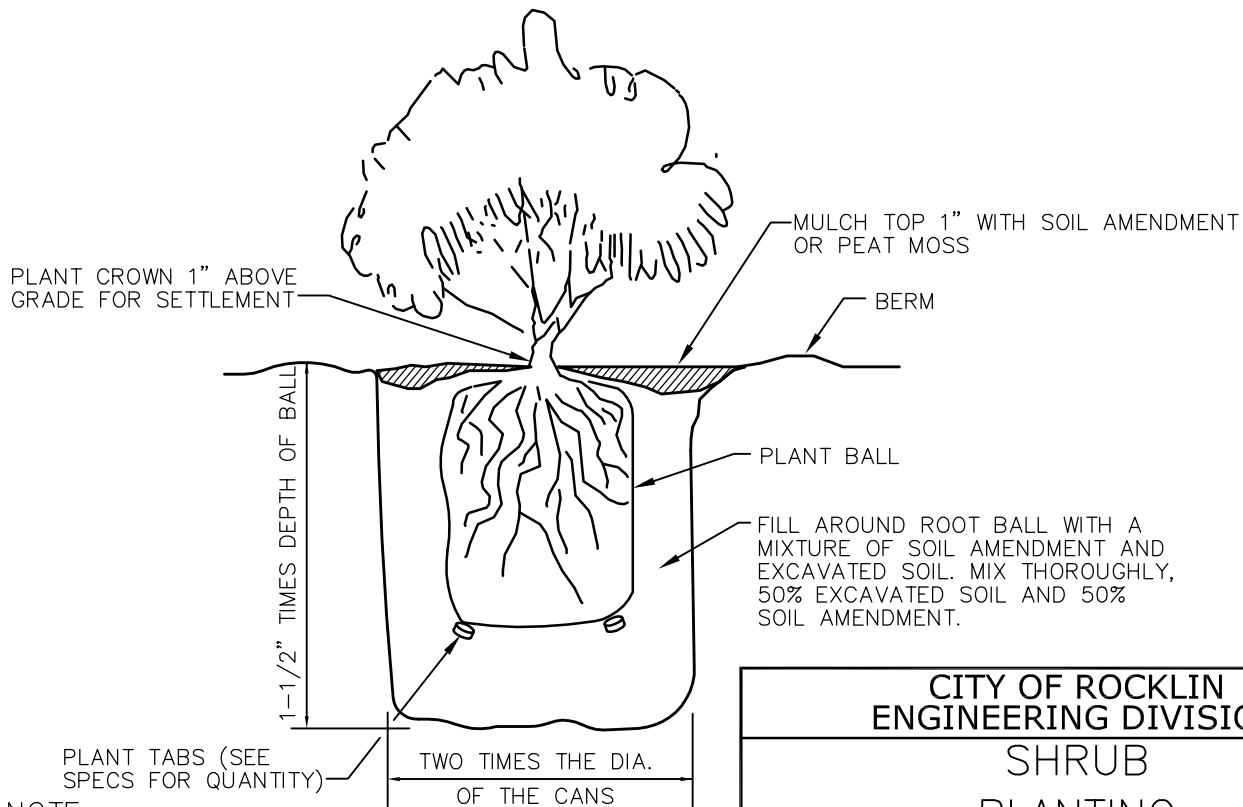

NOTE:  
SEE SPECIFICATION FOR SOIL AMENDMENT

*[Handwritten signature]*

<b>CITY OF ROCKLIN ENGINEERING DIVISION</b>	
<b>SHRUB PLANTING DETAIL</b>	
<b>SCALE: NONE</b>	<b>DWG #</b>
<b>DATE: AUGUST 2015</b>	<b>9-6</b>
<b>DRAWN BY: J. PINKHAM</b>	

DRAWING APPROVED - DIRECTOR OF PUBLIC SERVICES

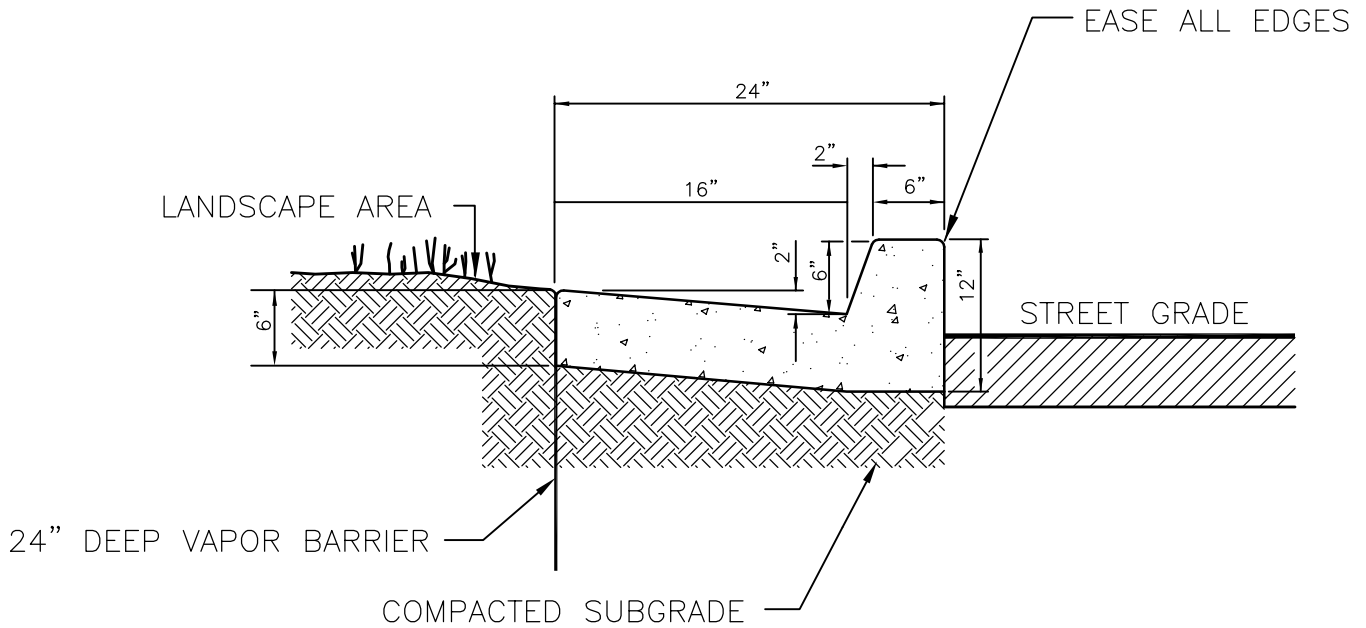

NOTES

1. PROVIDE SCORE JOINTS AT 10'-0" O.C. AND 3/8" BITUMINOUS FELT EXPANSION JOINTS AT 20'-0" O.C. WITH MASTIC SEALANT.
2. APPLY A PRE-EMERGENT HERBICIDE BENEATH GUTTER WITHIN MEDIANS.

DRAWING APPROVED – DIRECTOR OF PUBLIC SERVICES

<b>CITY OF ROCKLIN ENGINEERING DIVISION</b>	
CONCRETE LANDSCAPING GUTTER	
SCALE: NONE DATE: AUGUST 2015 DRAWN BY: J. PINKHAM	DWG # 9-7

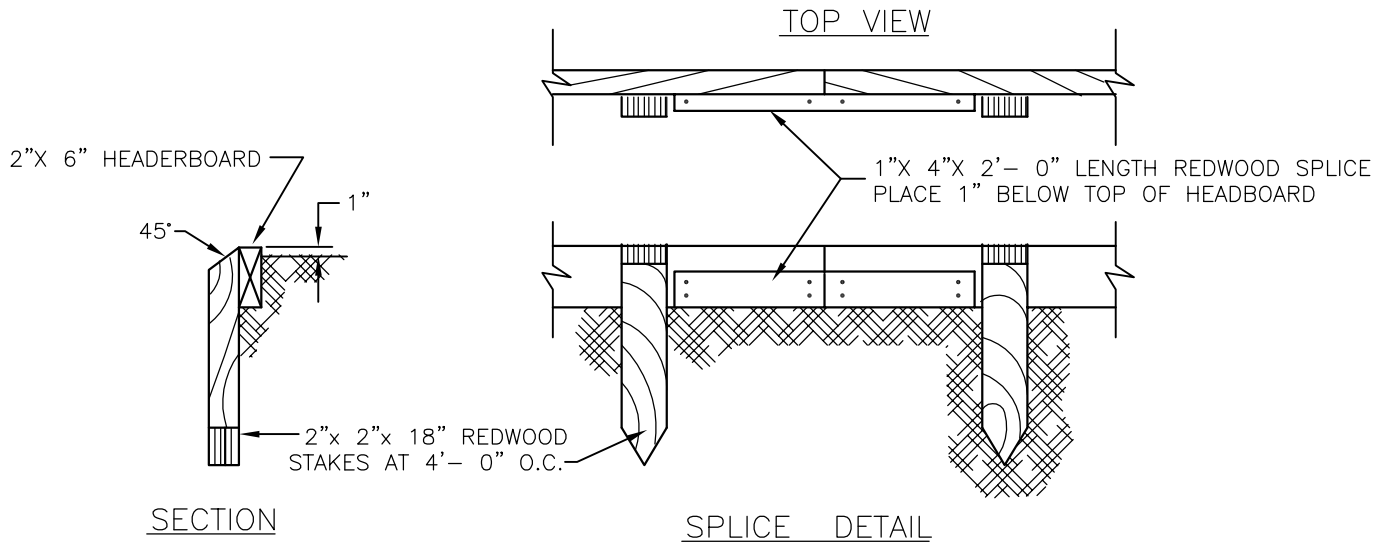

NOTES:

1. USE 2- 1"X 6" REDWOOD ON ALL CURVES (WHERE NECESSARY).
2. INSTALL ALL STAKES AND SPLICES ON PLANTING SIDE OF HEADER BOARD.
3. ALL NAILS SHALL BE GALVANIZED.
4. ALL LUMBER SHALL BE REDWOOD, ROUGH CONSTRUCTION HEART GRADE IN ACCORDANCE TO CALIFORNIA REDWOOD ASSOCIATION GRADING RULES.

*[Handwritten Signature]*

DRAWING APPROVED - DIRECTOR OF PUBLIC SERVICES

CITY OF ROCKLIN  
ENGINEERING DIVISION

REDWOOD  
HEADERBOARD  
DETAIL

SCALE: NONE  
DATE: AUGUST 2015  
DRAWN BY: J. PINKHAM

DWG #  
9-8



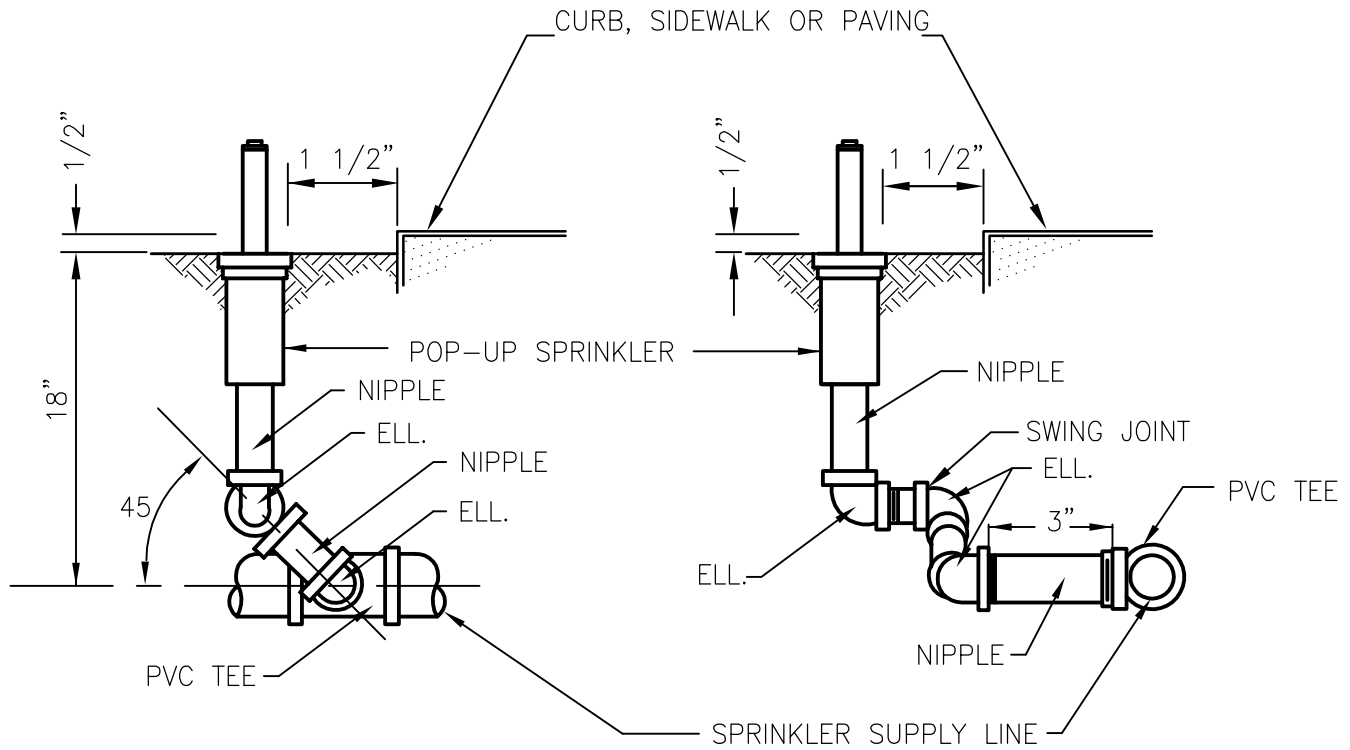

NOTES:

1. HEAD TO BE INITIALLY INSTALLED AT FINISHED GRADE.
2. PIPING & FITTING FROM LATERAL LINE TO SPRINKLER HEAD INLET TO BE SAME SIZE AS THE SPRINKLER INLET OPENING.
3. ALL THREADED FITTINGS SHALL BE INSTALLED USING A NON-HARDENING SEALANT COMPATABLE WITH PVC.
4. SWING JOINT SHALL BE PVC SCHEDULE 80 AND PVC SCHEDULE 40 FITTINGS.

DRAWING APPROVED – DIRECTOR OF PUBLIC SERVICES

<b>CITY OF ROCKLIN ENGINEERING DIVISION</b>	
POP-UP LAWN SPRINKLER	
SCALE: NONE DATE: DECEMBER 2015 DRAWN BY: J. PINKHAM	DWG # 9-9

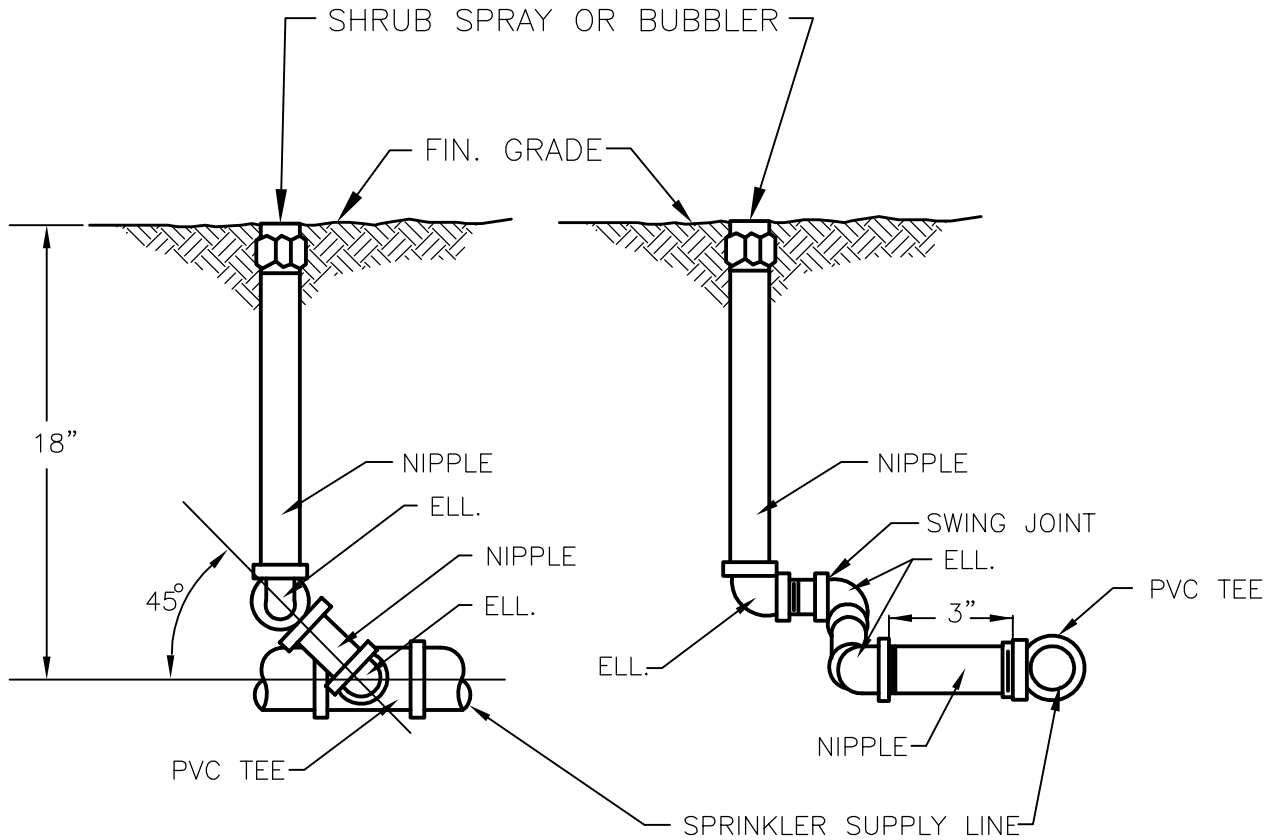

*J. Pinkham*

DRAWING APPROVED – DIRECTOR OF PUBLIC SERVICES

NOTES:

- 1) SWING JOINT SHALL BE PVC SCHEDULE 80 NIPPLES AND PVC SCHEDULE 40 FITTINGS.

**CITY OF ROCKLIN  
ENGINEERING DIVISION**

**BUBBLER**

**BELOW  
GRADE**

**SCALE: NONE  
DATE: AUGUST 2015  
DRAWN BY: J. PINKHAM**

**DWG #  
9-10**

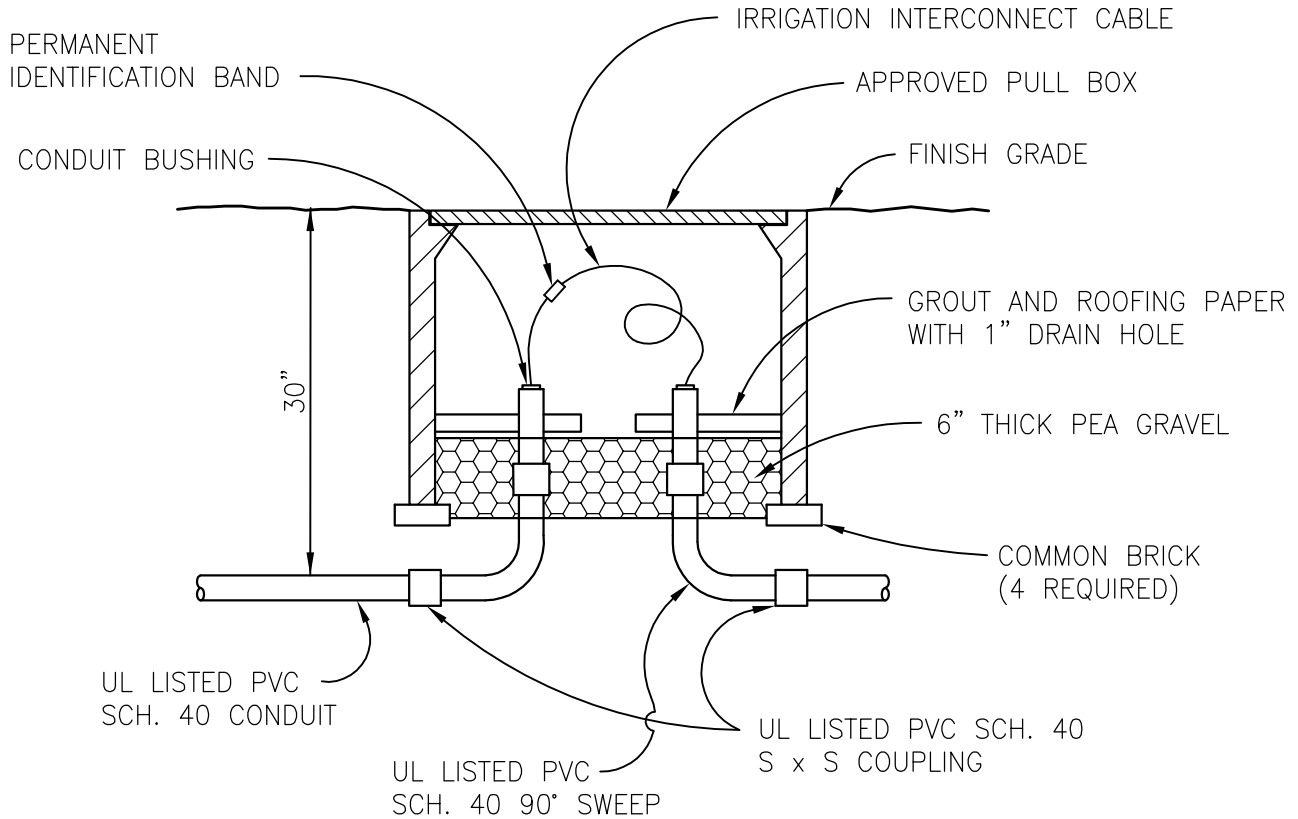

NOTE:

1. THE ENDS OF THE CONDUIT SHALL BE CAPPED UNTIL PULLING OF CONDUCTORS IS STARTED.

DRAWING APPROVED – DIRECTOR OF PUBLIC SERVICES

**CITY OF ROCKLIN  
ENGINEERING DIVISION**

**PULL BOX**

**SCALE: NONE  
DATE: MARCH 2006  
DRAWN BY: J. PINKHAM**

**DWG #  
9-11**

WIRE SERVICE LOOP (LOOP ENOUGH WIRE TO EXTEND WIRE BUNDLE 6" ABOVE GRADE)

APPROVED WATERPROOF CONNECTOR

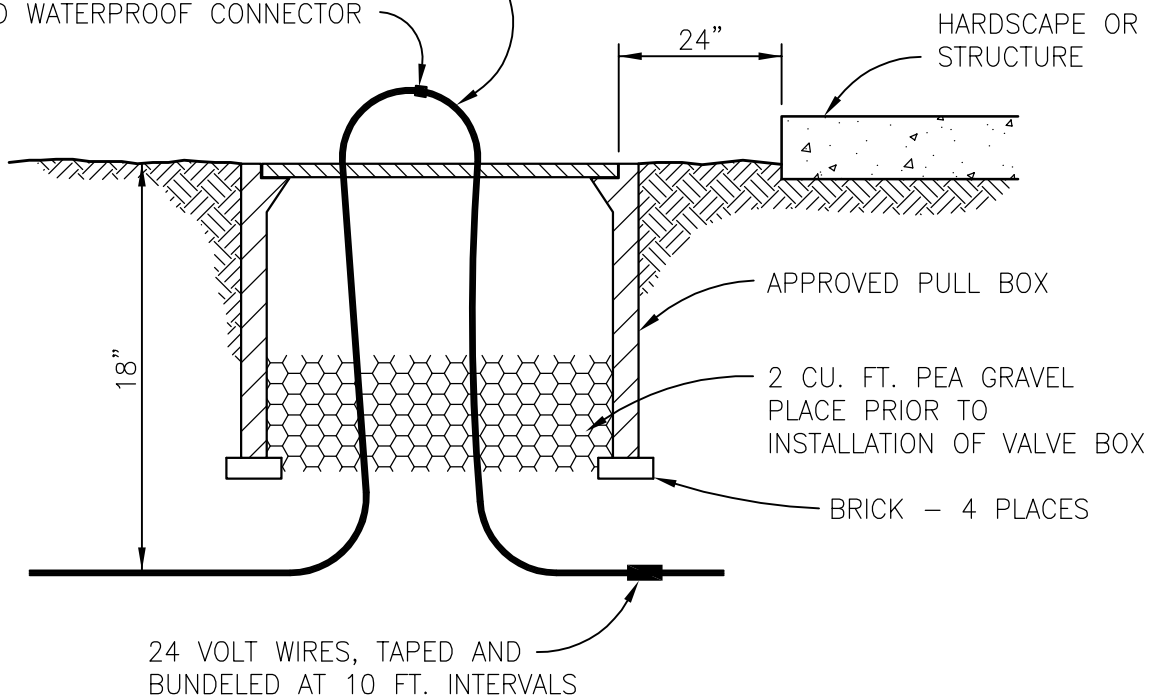

*[Handwritten signature]*

DRAWING APPROVED – DIRECTOR OF PUBLIC SERVICES

<b>CITY OF ROCKLIN ENGINEERING DIVISION</b>	
24 VOLT SPLICE BOX	
SCALE: NONE	DWG #
DATE: AUGUST 2015	9-12
DRAWN BY: J. PINKHAM	

MOUNT AUTOMATIC CONTROLLER  
ON MOUNTING BRACKETS INSIDE  
APPROVED PROTECTIVE ENCLOSURE

COMMON WIRE SHALL BE TIED INSIDE  
HOUSING WHEN REQUIRED

ADD 1" CONDUIT

FINISH GRADE

CONCRETE FOOTING - INSTALL 3" MIN.  
ABOVE GRADE AND SLOPE CONCRETE  
AT 2% TO DRAIN.

2" DIAMETER PVC SWEEP  
ELBOW CONTROL WIRING  
(AWG UF, #14). SECURE  
TO CONTROL UNIT AT  
TERMINALS PROVIDED IN  
CONTROL UNIT - UNLESS  
OTHERWISE NOTED.

ELECTRICAL CONDUIT TO SOURCE  
(CONTROL UNIT ELECTRICAL  
REQUIREMENTS: 120 60~, 2 AMPS MAX.)

ONE COMMON WIRE  
TO ALL RCV'S

ONE CONTROL WIRE  
TO EACH RCV

CONDUIT & IRRIGATION  
INTERCONNECT WHEN  
REQUIRED

NOTES:

1. COMMON WIRE TO BE WHITE & CONTROL WIRES TO BE COLOR CODED.
2. NO SPLICES SHALL BE MADE BETWEEN CONTROLLER & REMOTE CONTROL VALVE.
3. ALL WIRING, CONDUIT OR PLUMBING TO GO THROUGH BOTTOM OF CONCRETE FOOTING
4. ALL ELECTRICAL SERVICES SHALL CONFORM TO PG&E AND BE IN CONFORMANCE WITH THE NATIONAL ELECTRIC CODE STANDARDS.

DRAWING APPROVED - DIRECTOR OF PUBLIC SERVICES

CITY OF ROCKLIN  
ENGINEERING DIVISION  
EXTERIOR MOUNT  
AUTOMATIC  
CONTROLLER

SCALE: NONE	DWG #
DATE: DECEMBER 2015	9-13
DRAWN BY: J. PINKHAM	

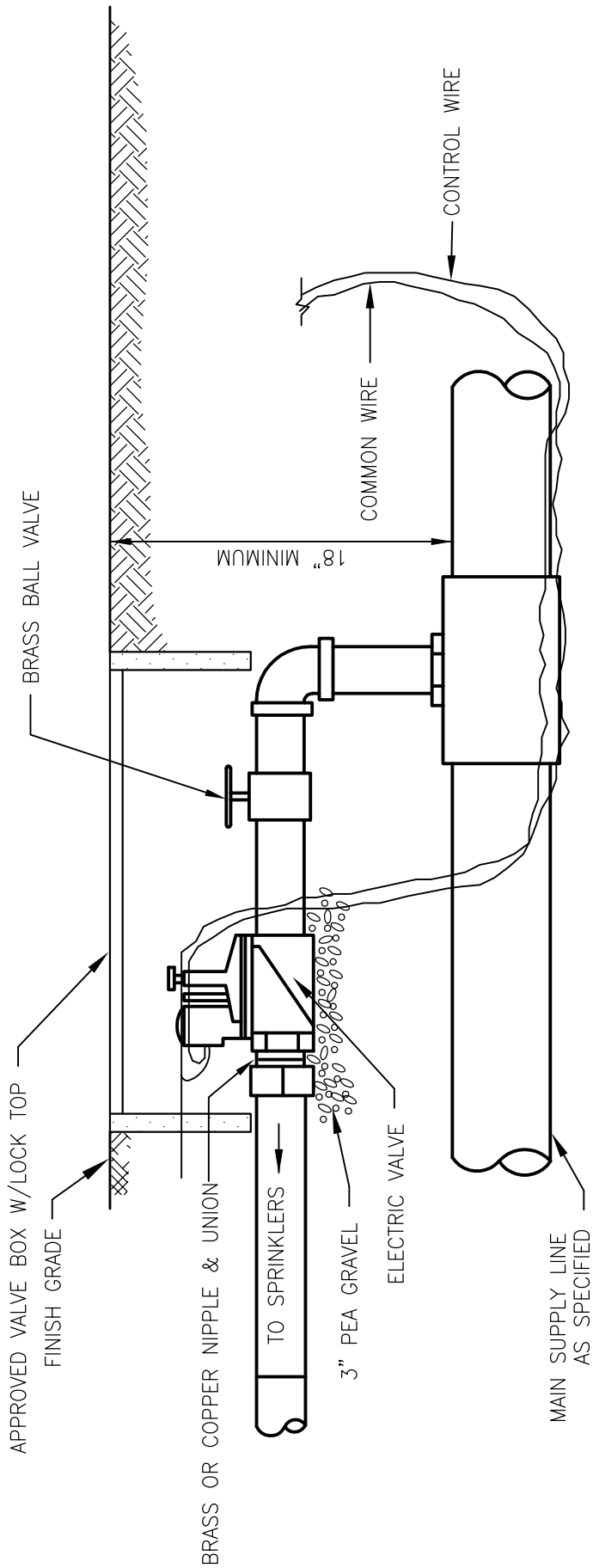

*Handwritten signature*

DRAWING APPROVED – DIRECTOR OF PUBLIC SERVICES

CITY OF ROCKLIN ENGINEERING DIVISION	
REMOTE MASTER CONTROL VALVE	
SCALE: NONE	DWG # 9-14
DATE: AUGUST 2015	
DRAWN BY: J. PINKHAM	

NOTE:  
ALL MATERIAL SPECIFICATIONS SUCH AS TYPE OF SPRINKLER EQUIPMENT, PIPE, FITTINGS  
CONDUIT, WIRING, VALVE BOXES, RISERS ETC. SHALL BE AS SPECIFIED ON IRRIGATION PLAN.

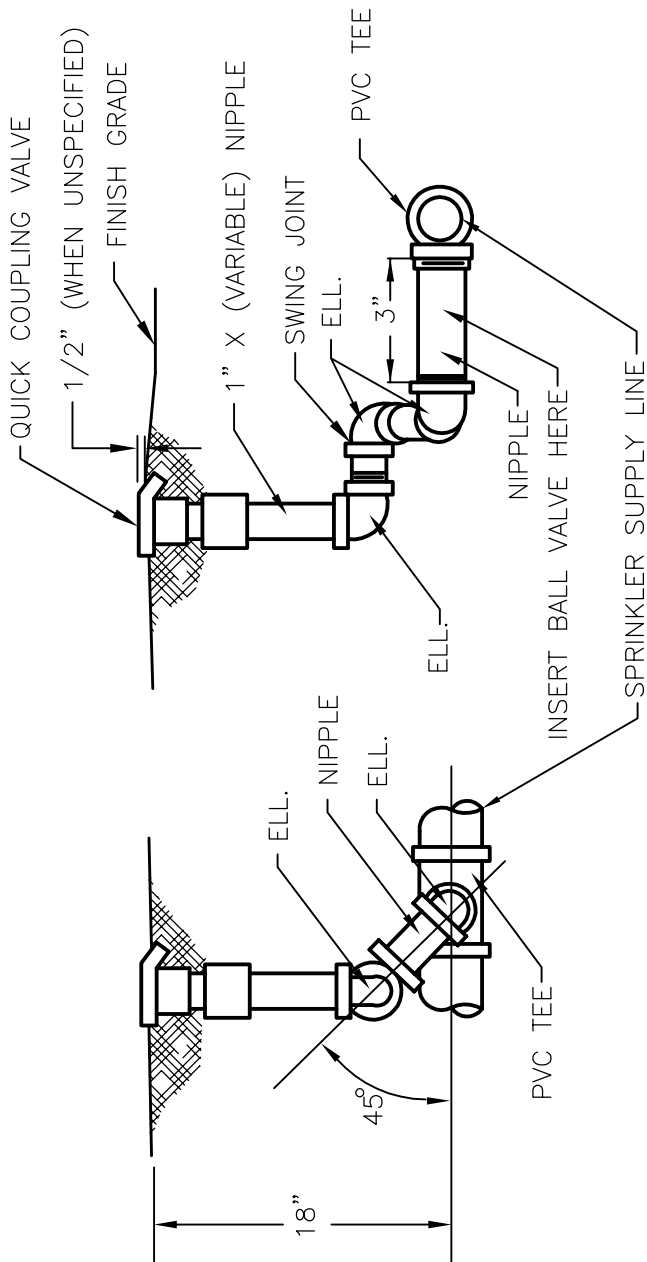

NOTE:

INSTALLATION OF SWING JOINTS SHALL BE ON A 45° ANGLE TO HORIZONTAL.  
 ALL PIPES AND FITTINGS SHALL BE BRASS OR PVC SCHEDULE 80 EXCEPT  
 AS SPECIFIED ON THE MAIN SUPPLY LINE.



DRAWING APPROVED – DIRECTOR OF PUBLIC SERVICES

CITY OF ROCKLIN  
 ENGINEERING DIVISION

QUICK

COUPLER  
 VALVE

SCALE: NONE

DATE: DECEMBER 2015

DRAWN BY: J. PINKHAM

DWG #

9-15

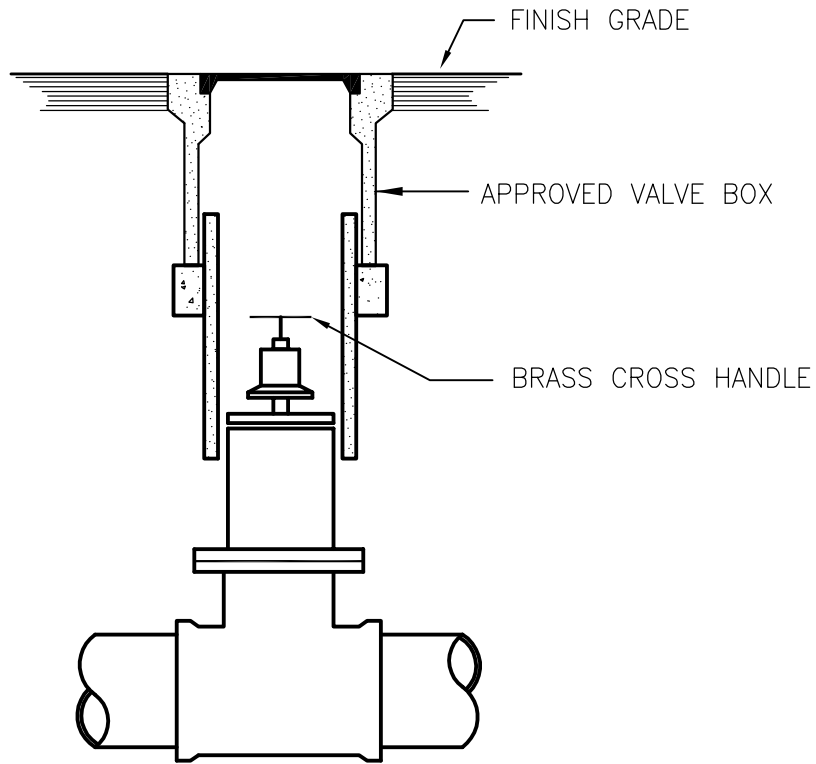

NOTES:

- A. GATE VALVES, 2 INCHES OR SMALLER, SHALL HAVE BRONZE BODIES, RISING STEMS, AND BRASS CROSS HANDLES. GATE VALVES SHALL BE NIBCO CLASS T-113, T-111, THREADED OR APPROVED EQUAL.
- B. GATE VALVES 2-1/4 INCHES AND LARGER SHALL BE AWWA APPROVED AND HAVE FLANGED CONNECTIONS, A 2-INCH SQUARE OPERATING NUT, CAST IRON BODIES, AND HAVE AN ARROW CAST IN METAL INDICATING THE DIRECTION OF WATER FLOW. GATE VALVES SHALL BE NIBCO F-619, SOTCKHAM G-612, KENNEDY 561X, OR APPROVED EQUAL.

DRAWING APPROVED – DIRECTOR OF PUBLIC SERVICES

<b>CITY OF ROCKLIN ENGINEERING DIVISION</b>	
GATE VALVE	
SCALE: NONE DATE: DECEMBER 2015 DRAWN BY: J. PINKHAM	DWG # 9-16



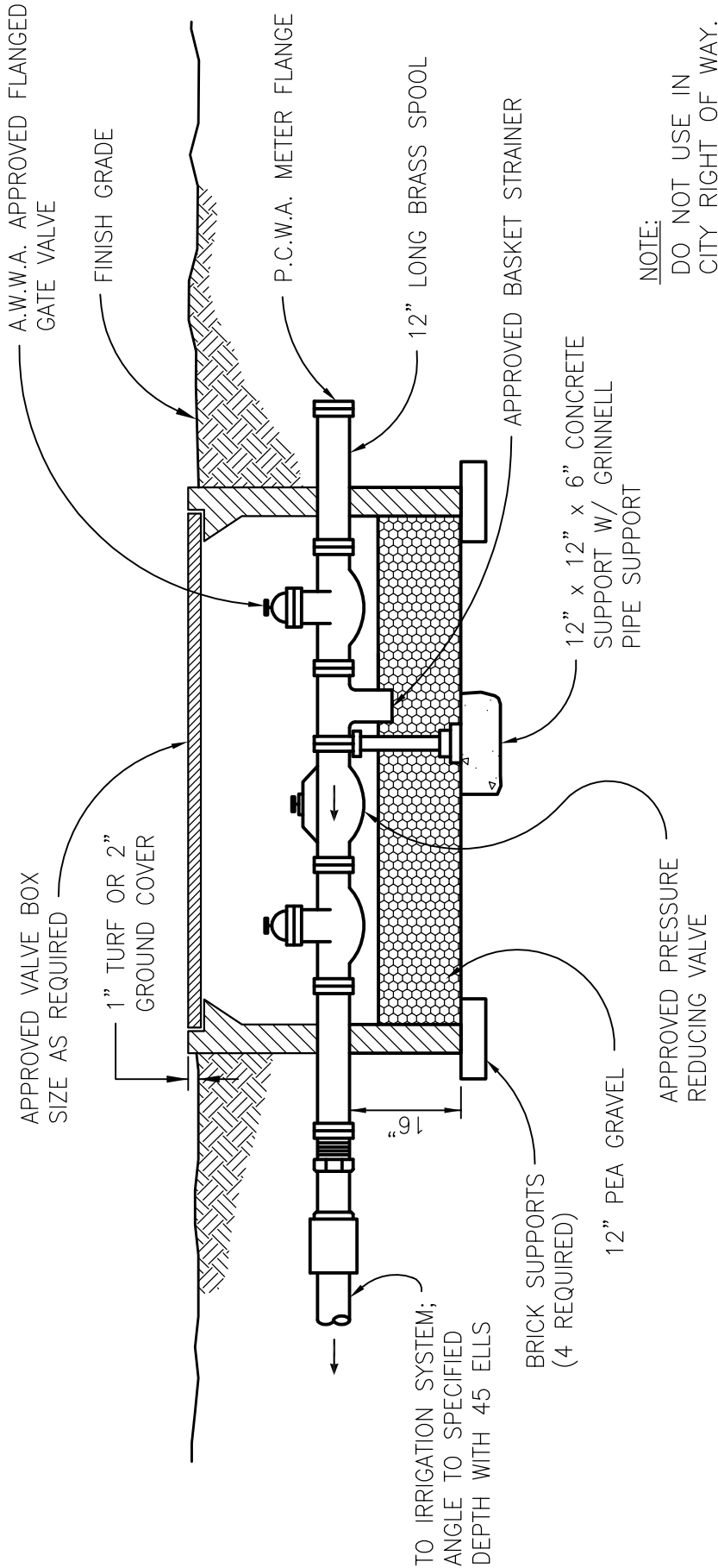

NOTE:  
DO NOT USE IN  
CITY RIGHT OF WAY.

<b>CITY OF ROCKLIN ENGINEERING DIVISION</b>	
STRAINER / PRESSURE REDUCING VALVE ASSEMBLY	
SCALE: NONE	DWG # 9-17
DATE: DECEMBER 2015	
DRAWN BY: J. PINKHAM	

*J. Pinkham*

DRAWING APPROVED - DIRECTOR OF PUBLIC SERVICES

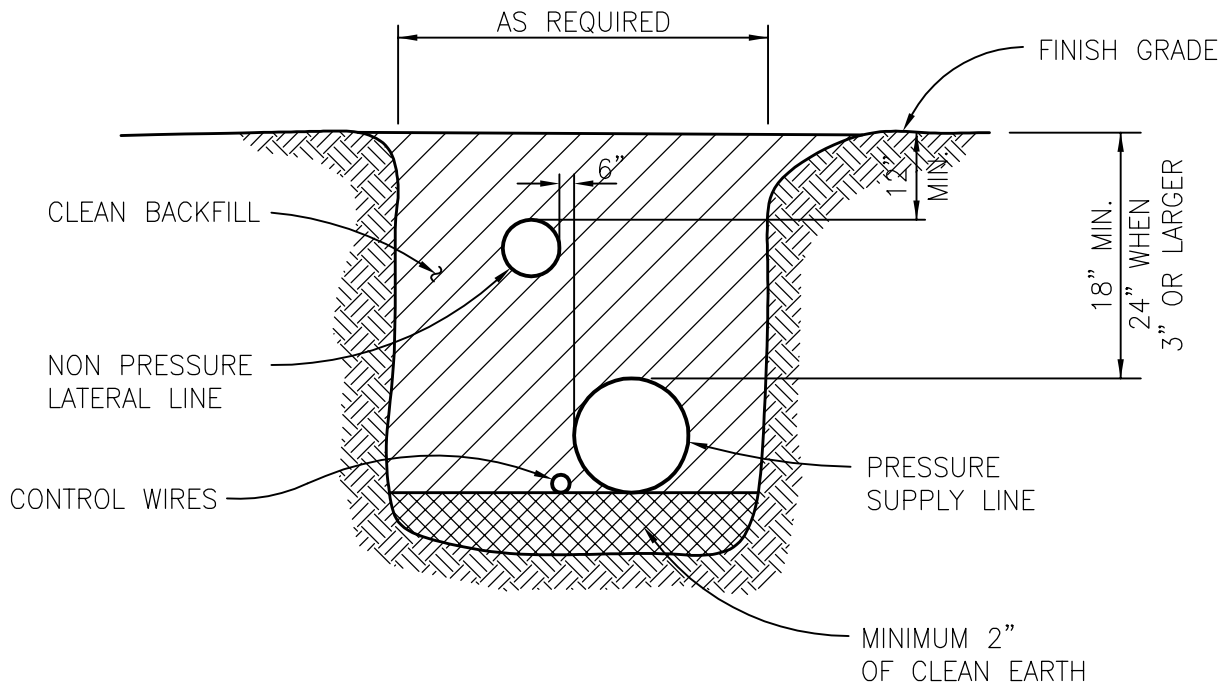

NOTES:

1. BELOW PAVED AREAS, A MINIMUM LAYER OF 6" CLEAN FILL SAND SHALL BE INSTALLED ABOVE AND BELOW PIPING.
2. WHEN USING RECLAIMED WATER, MAINTAIN A MINIMUM 10' HORIZONTAL SEPARATION BETWEEN POTABLE AND RECLAIMED PRESSURE LINES. WHERE LINES CROSS, PROVIDE PVC SLEEVE FOR POTABLE LINE MIN. 5' EACH SIDE OF RECLAIMED LINE.

DRAWING APPROVED – DIRECTOR OF PUBLIC SERVICES

CITY OF ROCKLIN ENGINEERING DIVISION	
PIPE DEPTH IN TRENCHES	
SCALE: NONE	DWG #
DATE: AUGUST 2015	9-18
DRAWN BY: J. PINKHAM	

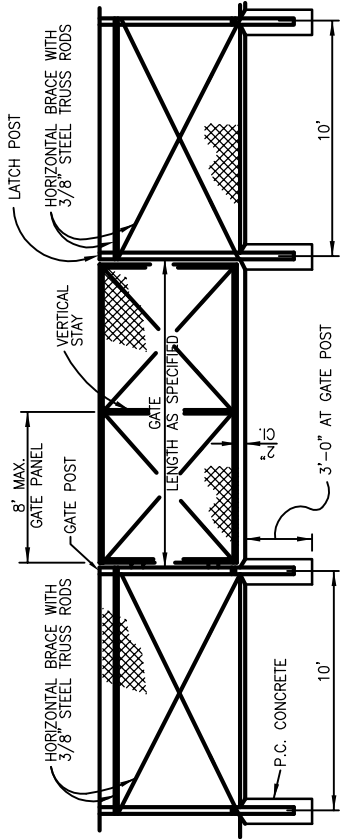

TYPE CL-4 = 48" FABRIC  
TYPE CL-6 = 72" FABRIC

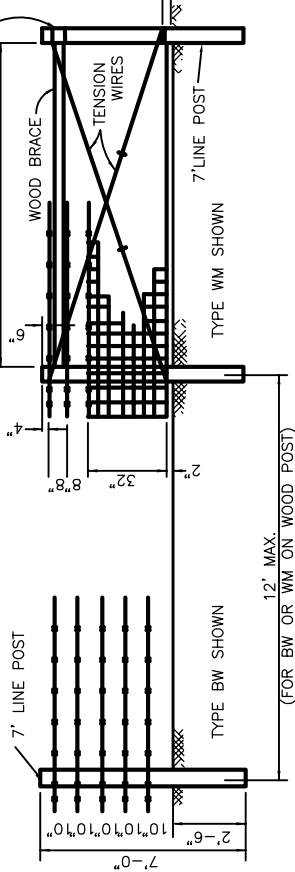

PULL POST ASSEMBLY

AT 660' MAXIMUM INTERVALS FOR WM FENCE.  
AT 1320' MAXIMUM INTERVALS FOR BW FENCE.

WOOD POST INSTALLATION

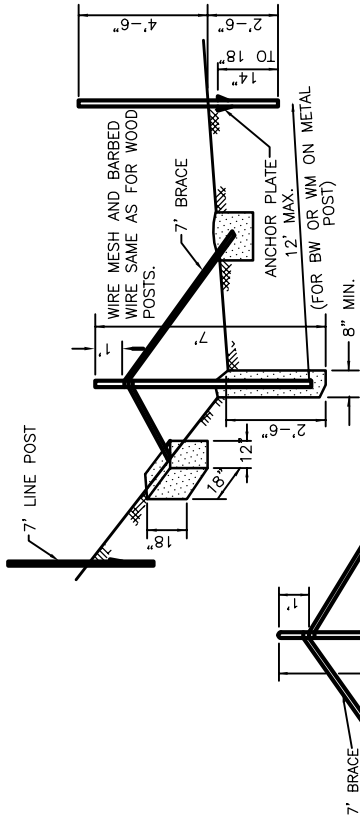

PULL POST ASSEMBLY

AT 500' MAXIMUM INTERVALS FOR WM FENCE.  
AT 1000' MAXIMUM INTERVALS FOR BW FENCE.

METAL POST INSTALLATION

TYPE BW = 5 LINES OF BARBED WIRE  
TYPE WM = WIRE MESH AND 3 LINES OF BARBED WIRE

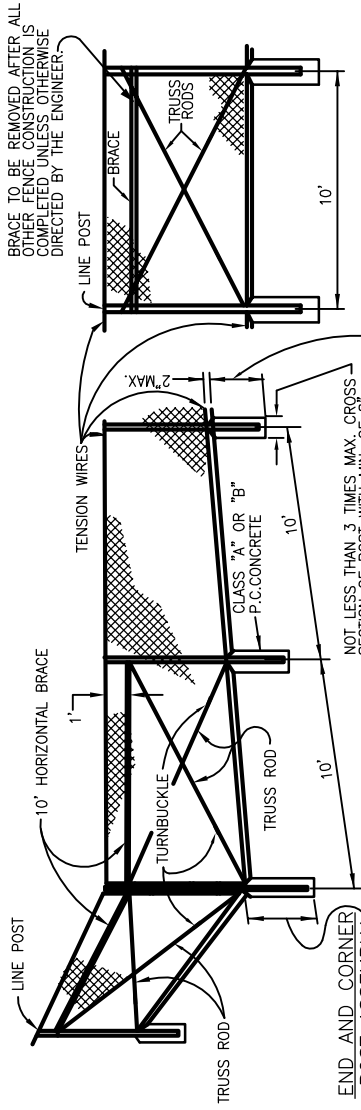

END AND CORNER POST ASSEMBLY

NOT LESS THAN 3 TIMES MAX. CROSS SECTION OF POST WITH MIN. OF 8"  
3'-6" FOR FABRIC LESS THAN 60" HIGH  
3'-0" FOR FABRIC 60" AND OVER.

PROPERTY FENCE

BRACE TO BE REMOVED AFTER ALL OTHER FENCE CONSTRUCTION IS COMPLETED UNLESS OTHERWISE DIRECTED BY THE ENGINEER.

END AND CORNER POST ASSEMBLY

TYPE BW = 5 LINES OF BARBED WIRE  
TYPE WM = WIRE MESH AND 3 LINES OF BARBED WIRE

DRAWING APPROVED - DIRECTOR OF PUBLIC SERVICES

CITY OF ROCKLIN  
ENGINEERING DIVISION  
CHAIN  
LINK  
FENCE

SCALE: NONE  
DATE: AUGUST 2015  
DRAWN BY: J. PINKHAM  
DWG # 9-19